

Nice

Gate, garage door,  
barrier automation  
and control systems.

2026 Catalogue

# Gate & Door





# Nice Gate&Door Solutions

2026 Catalogue



Click and go to  
the pages

## Contents:

### WHY NICE

<b>Who We Are</b>	<b>4</b>
Integration into smart home systems	6
New MyGO transmitters	8
Compatibility and backward compatibility of the systems	9
New Robus motors <span>New</span>	10
New Spider motors	12
Glossary and legend	14

### SYSTEMS FOR THE SMART HOME 16

Yubii ecosystem and Yubii Home App	16
BiDi-ZWave	18
BiDi-WiFi	20
BiDi-WiFi Ext <span>New</span>	21

### PROGRAMMING UNIT

BiDi-WiFi	20
Pro-View	22 / 24
MyNice Pro App	23



Click and go to  
the pages

### FOR SWING GATES

Selection guide	54
-----------------	----

#### Surface-mounted

Toona 4	58
Toona 5	60
Toona HS <span>Hi Speed</span>	26
Toona 7	62
Wingo HS <span>Hi Speed</span>	28
Wingo 4	64
Wingo 5	66
Too	68
Titan HS <span>Hi Speed</span>	30

#### Integrated installation in post

Oltre 1824	70
------------	----

#### Surface-mounted, with articulated arm

Walky	72
Hopp	74
Hyke	76
Hyke HS <span>Hi Speed</span>	32
Hyppo 7000	78

#### Underground installation

S-Fab	80
M-Fab	82
M-Fab HS <span>Hi Speed</span>	34
L-Fab	84
L-Fab HS <span>Hi Speed</span>	36
Big-Fab	86

Accessories	88
Installation diagram	89
Accessories <span>Hi Speed</span>	46
Installation diagram <span>Hi Speed</span>	49

### FOR SLIDING GATES

Selection guide	94
-----------------	----

#### For residential use, also integrable on column

Naked	98
Slight	100

#### For residential use

Robus 400/600/800 <span>New</span>	102
Robus 600 HS <span>Hi Speed</span>	38
Robus HS <span>Hi Speed</span>	40
Run HS <span>Hi Speed</span>	42
Road	106
Robo 600	108

#### For residential and industrial use

Robus 1000	104
Robo 1000/1500 <span>New</span>	110
Run 1500	112
Run 1800/2500	114

#### For industrial use

Tub	116
-----	-----

Accessories	118
Installation diagram	120

### BARRIER GATE OPERATOR SYSTEMS

S/M/L Bar Selection guide	124
S-Bar	128
M-Bar	130
L-Bar	132

Wide Selection guide	134
Wide System	136

Accessories	138
Installation diagram	140

## FOR GARAGE DOORS AND SHUTTERS

### For garage doors

Selection guide	142
Spider 1200BLW	146
Spider 800/800W	148
Spido 600	152
Spido 1000	<b>New</b> 150
Spykit 650 HS BD	<b>Hi Speed</b> 44
Ten	158
Tenkit	160
Spykit 650/800 BD	154
Spykit 550	156
Soon	162
Sumo	164
Hyppo	166

### For balanced rolling doors

Selection guide	169
Rondo	170
RolSide 600/700	172
Accessories	174
Installation diagram	176

## CONTROL SYSTEMS

### Transmitters

MyGO BD	180
MyGO & MyGOFM	181
Era One LR & OXI LR	182
Era Inti	184
Era One	186
DOMi W3C	187
Receivers	188
OX4T	190

### Accessories

Nice Era photocells	191
Era Photocell S	192
Era Photocell M	194
Era Photocell L	196
Era Keypad	198
Era Keypad wireless	199
Era Key switch	200
Era Transponder reader	201
Era Post	202
Era Light	203
Wallyght	204
Solemyo	205
Mechanical sensitive edges	206
Inductive magnetic detector loop	206
FT210	207
F210	208
Kio, Kiomini	209

### Control units

Selection guide	210
Moonclever 824	211
Moonclever 424	212
MC800	213
MC200	214
MC200L	<b>New</b> 215
D-Pro 500	216
D-Pro 924	217

# Nice

## Who We Are



### True freedom is an open world.

**For us, opening is not just a gesture: it is freedom of movement, of time, of choice. It is an invitation to experience technology as something that simplifies life and opens up new possibilities.**

We design automation systems and smart solutions for space management, where functionality and design meet. For our partners, this means modular products, easy to install and reliable over time. For those who use them, it means living every day in a simpler and safer way: an experience that makes technology a natural part of daily life.

### Why Nice?

Because Nice is a global partner: we are present in over 100 countries, speak more than 20 languages, and bring with us the richness of over 40 nationalities. Because our portfolio covers every need for automation and smart space management, with solutions that integrate into a single complete ecosystem. Because our products combine innovation and simplicity: easy to install, intuitive to use, designed to improve quality of life.



### The value of design

For Nice, design is not just aesthetics. It is care for form and details, attention to the process from design to production, with the goal of making every interaction simpler and more natural. And it is user experience: systems that communicate with those who install them and those who use them, to turn technology into an intuitive, pleasant, and everyday gesture.

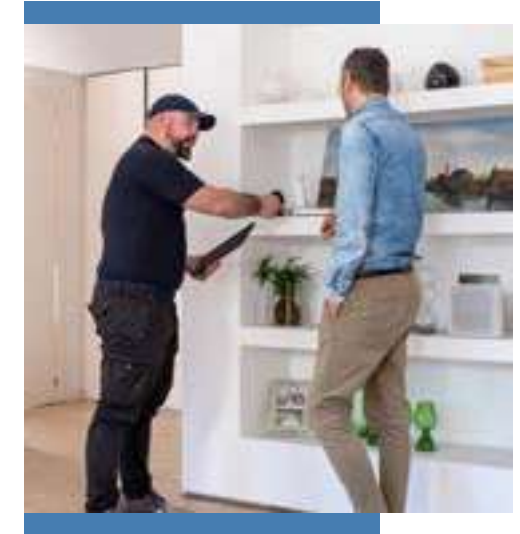

### Training alongside our partners.

We stand alongside installation professionals, offering comprehensive training on products and systems. Nice know-how becomes a concrete tool for professional growth, enabling us to confidently meet customer needs. The courses adapt to everyone's pace: in-person, via webinar, or online, to convey all technical knowledge and provide practical tools that facilitate daily work and improve the consumer experience.



### Quality and warranty

Every day, in our laboratories, we carry out rigorous and highly accurate tests, supported by cutting-edge technologies and state-of-the-art tools. Our goal is to ensure maximum safety, quality, reliability, and superior durability over time.

**The warranty on all Nice products is 3 years, or 5 years for tubular motors.**



### Our planet is the Earth, our home is the future.

**We design for a clean, sustainable, and safe future.**



At Nice, we believe that “true freedom is an open world,” and this principle also guides our commitment to sustainability. We want to create open, inclusive, and safe environments that promote well-being, innovation, and respect for the planet. We embrace sustainability to drive progress and improve people’s quality of life, while protecting the planet.

### Tailored for life, planet, and future.

For Nice, sustainability means improving the lives of those who choose us, while caring for the planet.

We develop solutions that optimize light, heat and energy, monitor air quality, and enhance well-being and safety.

We design systems that reduce consumption and environmental impact, promoting energy efficiency across everyday living.

Through Life Cycle Assessment and EPD certification, we create sustainable, safe and recyclable products and packaging — supporting conscious well-being and a more responsible future

# Nice

## Dialogue with your home.

### Can coming home be even easier?

Thanks to the connected automations, you can manage your home automations in total freedom and with ever greater personalisation.

What's more, thanks to the new Nice interfaces, automations for previously installed gates and garage doors can also be integrated into the smart home system and controlled easily via Amazon Alexa or Google Assistant.

*“Hey Google, open the gate”*

# Life is simpler.

“ Hey Google, close everything ”

“ Hey Google, did I close the garage? ”

You can control your home automations by voice In|commands in the simplest way possible, including from your smart watch or your car’s infotainment system, via Amazon Alexa or Google Assistant.



The Nice smart home system is highly integrated and safe. It can guarantee maximum simplicity of use and peace of mind when managing your home automations even remotely, warning you if there’s something wrong.

# Even when far from home.

Yubii Home App



MyNice App



More control, including from your smartphone. Via the Yubii Home or MyNice app, you can control all the automations even when you’re far from home. You can also choose how to personalise your home to suit everyone’s needs.

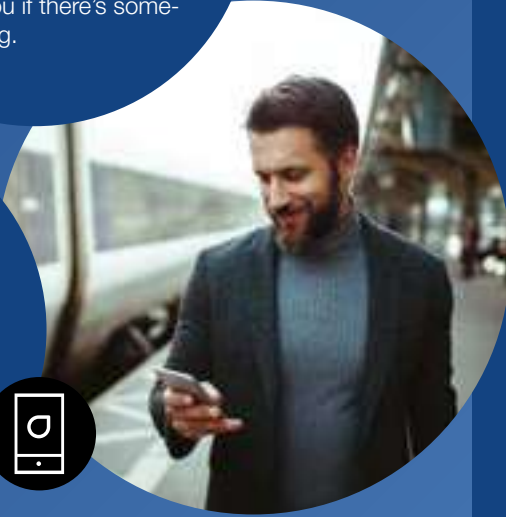

# More automations, more convenience.

The programming and communication interfaces make it easy to integrate Nice Gate&Door systems into the smart home system. The automation becomes smart and can be controlled via smartphone, tablet or voice control with Amazon Alexa or Google Assistant.



### BIDI-WIFI

Plug-in communication and programming interface to configure the automation via smartphone.



→ 20



### BIDI-ZWAVE

Plug-in interface for communicating between the Z-Wave™ gateway and Nice motors.



→ 18

# Nice

## MyGO, transmitters designed for any style and taste.

The new **MyGO unidirectional and bidirectional transmitters** with an effective, sleek design. With 433.92 MHz radio frequency, available in 2, 4 and 8-channel versions, compatible with Nice O-Code encoded receivers.

The range also includes MYGO FM with 868.46 MHz, with 2 or 4 channels guaranteeing greater immunity from interference.

**Everything is simple with MyGO, everything works even better: programming and control in just a few steps.**



**Remotely activate an additional remote control** through the Pro-View interface and MyNice Pro app or use a MYGOBD transmitter already enabled in the receiver.



**Check your gate/garage door at any time with a simple click.**



**Info LED flashes red to signal low battery during transmission.**



The **bidirectional radio protocol uses GFSK** modulation to ensure immunity from interference.



**EPD**<sup>®</sup>  
THE INTERNATIONAL EPD<sup>®</sup> SYSTEM

Find out more on page → 181

# Do you want more from your automations?

## More control, fewer worries.

By integrating your automations into the Nice ecosystem, you can live your home with more comfort and fewer worries.

### Do you already have a Nice automation? Upgrade, it couldn't be easier!

With the **OXIBD** receiver, compatible with all Nice control units with SM connector and with all Nice radio protocols.

### Is the gate or garage door motor not Nice?

With the **OX2UBP** hardware interface, installed together with OXIBD, third-party motors can also be integrated into the Yubii ecosystem.



Find out more on page → 188

# Robus and Robo series.

The new generation of motors for sliding gates from 400 to 1500 kg, also available in Hi-Speed version: high-performing, intelligent, connected.

**Innovative design conceived for connectivity**, to make these motors high-performing and always under control.

**Robustness and efficiency** thanks to selected materials, refined design, and high-performance lubrication.

**Easy to install** thanks to the new foundation plate equipped with practical adjustment systems.

**Fast and intuitive programming via the MyNice Pro app.**



Find out more on page → 96



**Stand-by consumption 0.4W**  
(RBS400/RBS600/RBS800)

**Minimal style:**  
simple shapes,  
neutral colors,  
essential lines.



**Functional release lever** for quick and secure fastening, protecting the automation.

**Adjustable photocell and passage light can be integrated** in the motor; increased safety in the gate movement area. (RBS600HS)

**Eye Check system**  
The integrated LED light indicates the status of the automation and connected accessories.

**NICE GREEN INNOVATION**

**Environmental savings**  
Environmental Product Declaration (EPD) available. CO<sub>2</sub> emissions compared to the previous Nice model\*:

**-80%**



\* Verification of the declaration and data according to internal EPD management procedure; the process is verified by an accredited third party. The comparison refers to the RB600 model.

## Solutions for every application context:

### Compact versions for residential installations.

#### For sliding gates up to 800 kg with leaves up to 8 meters.

Non-reversible gearmotor, magnetic limit switch (Robus) and electromechanical (Robo), control unit and integrated radio receiver, also available in fast Hi-Speed version.

All models are available in two convenient kits.

24 VDC



**ROBUS600 HS**  
FOR LEAVES UP TO **600 KG**.

**HI-SPEED VERSION**



**ROBUS400**  
FOR LEAVES UP TO **400 KG**.

**ROBUS600**  
FOR LEAVES UP TO **600 KG**.

**ROBUS800**  
FOR LEAVES UP TO **800 KG**.

**New**

230 VAC



**ROBO600**  
FOR LEAVES UP TO **600 KG**.

230 VAC

**New**



**ROBO1000**  
FOR LEAVES UP TO **1000 KG**.

**ROBO1500**  
FOR LEAVES UP TO **1500 KG**.

### Robust versions, suitable for high-intensity industrial installations.

#### For sliding gates up to 1500 kg with leaves up to 12 meters.

Non-reversible gearmotor, electromechanical limit switch, control unit and integrated radio receiver.

Nice

# Spider: new motors for garage doors.

New motor for sectional doors up to **16.9 m<sup>2</sup>** and up-and-over doors up to **19.5 m<sup>2</sup>**. Two models with control unit and integrated bidirectional receiver:

- **1200N** with **Brushless technology** and **built-in Wi-Fi**,
- **800N** with built-in Wi-Fi.

With Spider the garage automation also becomes **connected and sustainable**.

Find out more on page → 142

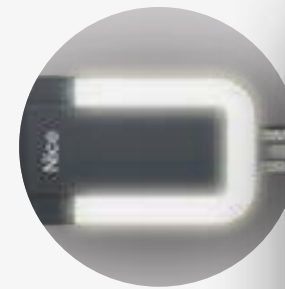

**Built-in LED** courtesy light



**Compact and robust** metal base, 10.5 cm high

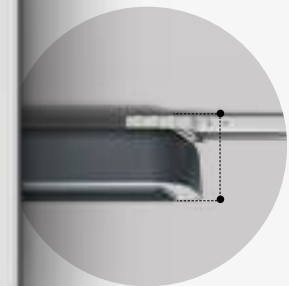

**Longer usable travel**  
+20 cm

**Minimal bulk**  
3 cm high

**Carriage** 100% integrated

## Spider, performance and design:



Equipped with **brushless motor** designed for intensive use up to 150 cycles per day (SPIDER1200BLW).



**Stand-by consumption <0.5W** (SPIDER800).



Quick and easy programming via the **MyNice Pro app**.



**Built-in anti-intrusion system** for detecting forced entry through the garage door.



**Eye Check System** for monitoring automation status at any time.



## Glossary and legend of symbols

---

**BiDi****Bidirectional radio protocol**

Allows two-way communication between the transmitter and receiver, providing safer signal transmission and the possibility of receiving feedback on command reception and automation status.

**Yubii****Yubii ecosystem**

Connects all new and existing Nice automations in the home and allows them to be controlled remotely via App.

→ 16

**Solemyo****Solemyo System**

Solar power system for gate, garage door and road barrier automation systems without access to a mains power connection. Installable anywhere: without the need for connections or excavations, even in the most remote locations or those difficult to access with the power mains.

→ 205

**Opera****Opera Control**

For controlling, programming and checking automation systems, including remotely. The Opera system consists of the Inti, One and One BD transmitters, OXI and OXIBD receivers, the O-Box connection interface and communication software. All components communicate via BUS-T4 or O-Code rolling code to guarantee more secure transmissions.

**BlueBus****Nice BlueBUS communication system**

Allows all devices to be easily connected to the control unit with just two wires, by simply connecting them in parallel and selecting the addressing jumpers according to the required function.

**BUS T4****BUS T4 connection**

Communication protocol allowing creation of extensive networks of compatible automation systems, all managed from a single point via Nice programmers.

# Systems for the smart home

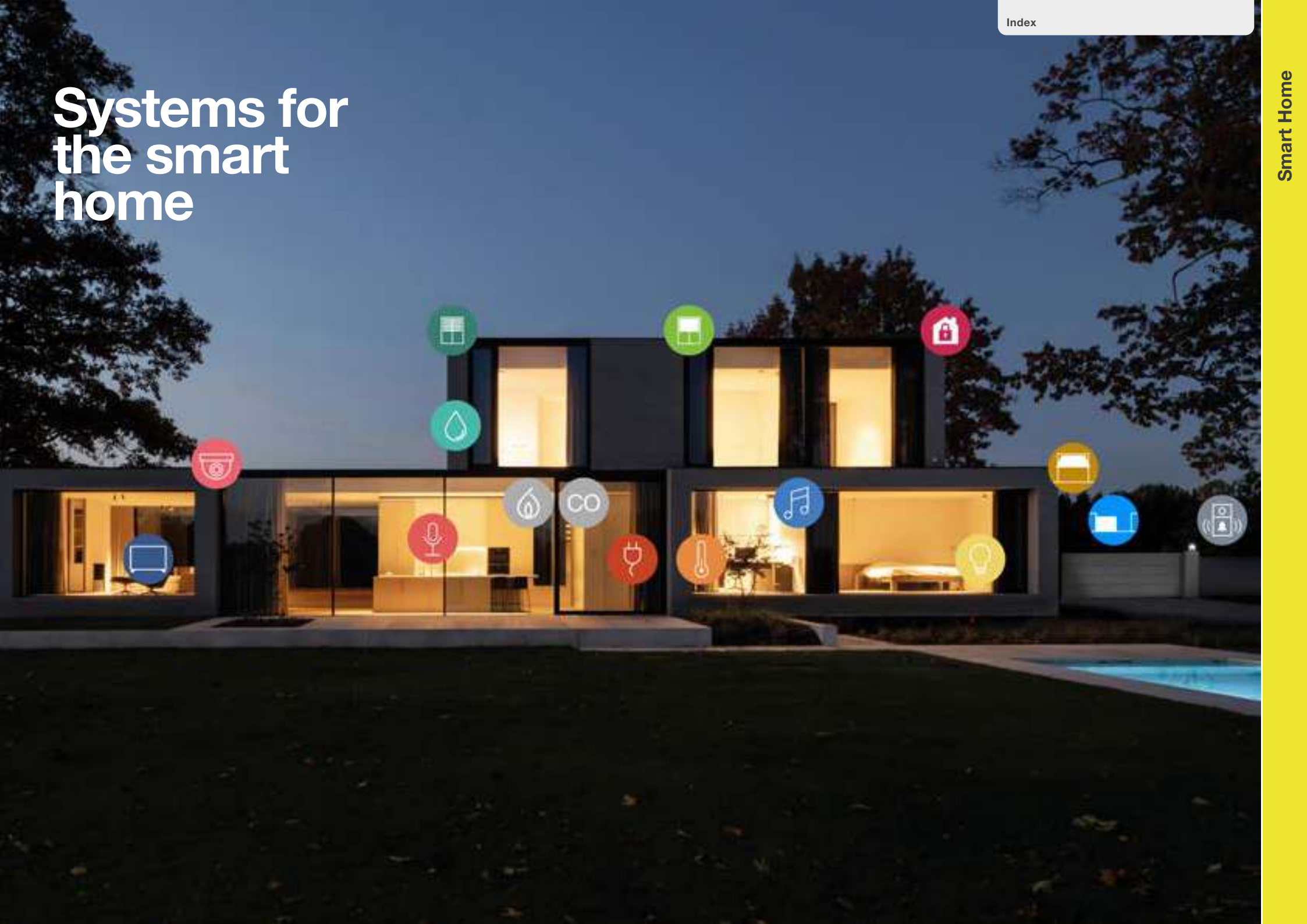

# Nice Infinite scenarios with Yubii

**Yubii**, a single ecosystem to connect, simplify and control all home automations.

Connect automations via the Nice gateway to create personalised scenarios that can be controlled either by smartphone or by setting a button on the bidirectional remote control.

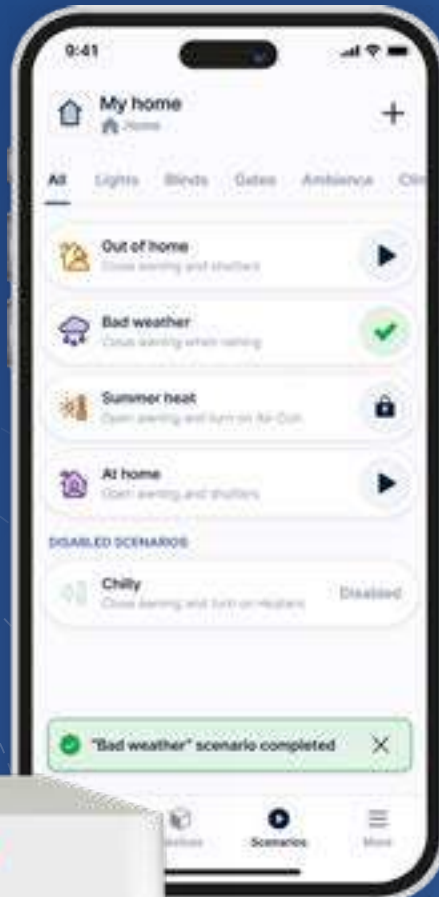

## Yubii Home App



GET IT ON  
Google Play

Download on the  
App Store



### Compatible with:



### Communicates via protocols:



Radio Nice

Radio elero



**RGBW-Control**  
For controlling light colour.

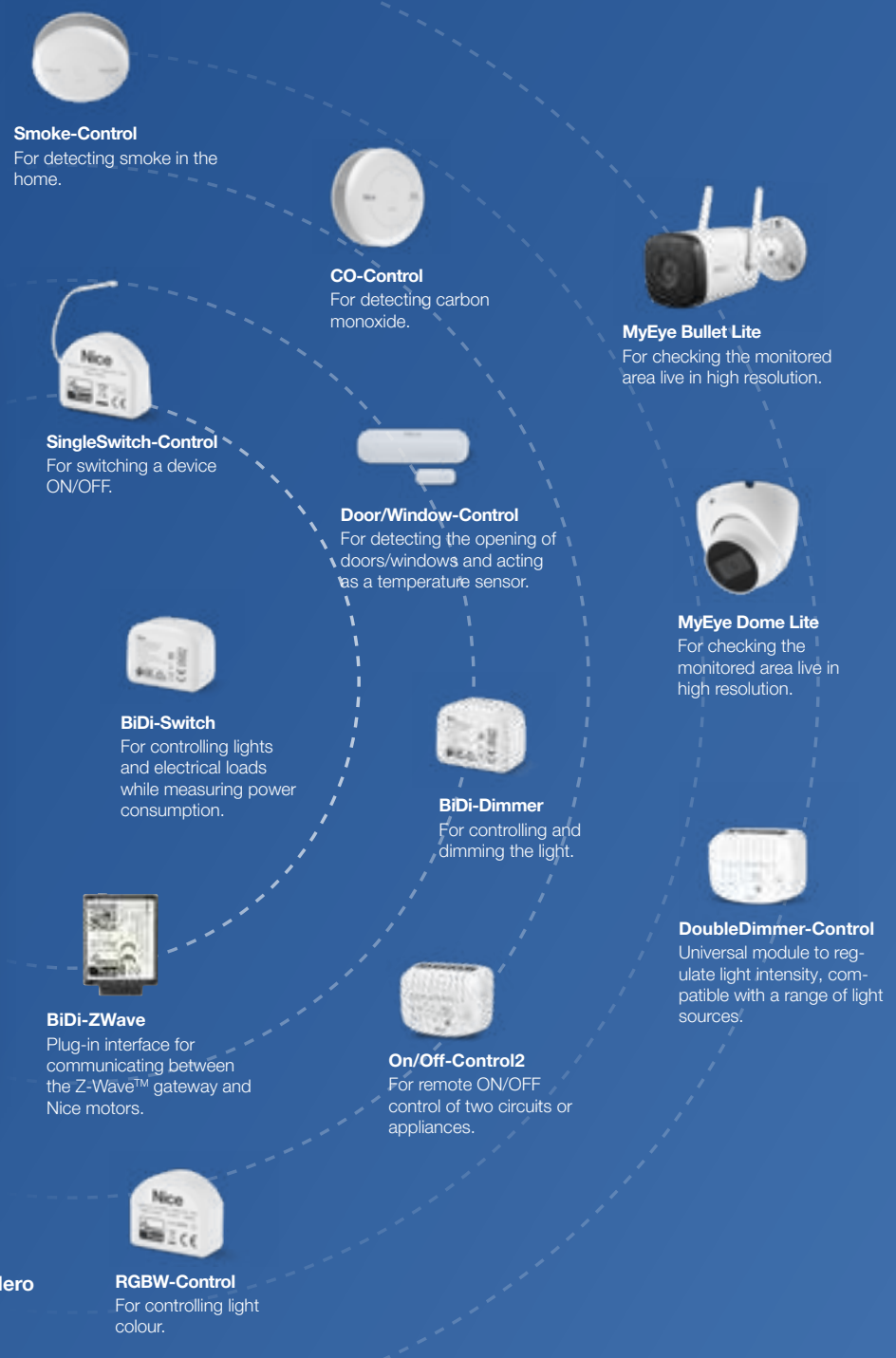

**Smoke-Control**  
For detecting smoke in the home.



**CO-Control**  
For detecting carbon monoxide.



**MyEye Bullet Lite**  
For checking the monitored area live in high resolution.



**SingleSwitch-Control**  
For switching a device ON/OFF.



**Door/Window-Control**  
For detecting the opening of doors/windows and acting as a temperature sensor.



**MyEye Dome Lite**  
For checking the monitored area live in high resolution.



**BiDi-Switch**  
For controlling lights and electrical loads while measuring power consumption.



**BiDi-Dimmer**  
For controlling and dimming the light.



**BiDi-ZWave**  
Plug-in interface for communicating between the Z-Wave™ gateway and Nice motors.



**DoubleDimmer-Control**  
Universal module to regulate light intensity, compatible with a range of light sources.



**On/Off-Control2**  
For remote ON/OFF control of two circuits or appliances.

## Scenario idea:

**Geolocation:** if activated, the gate and garage will open automatically as you approach and reach the set distance away.

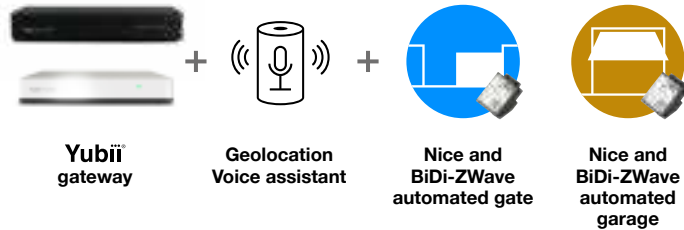

**Security:** you can monitor the perimeter of your home, see who is ringing the doorbell, and open the gate with a simple click, even remotely.

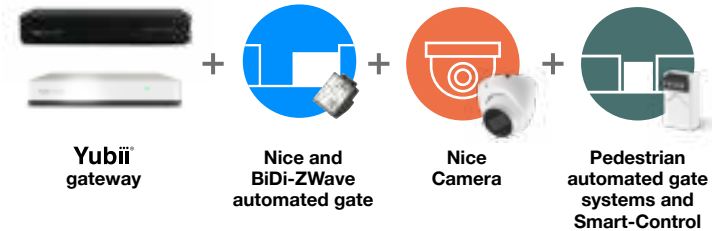

**Protection from invisible danger:** if high concentrations of carbon monoxide are detected in the air, ventilation is activated, the garage door is opened and a notification is sent to your smartphone.

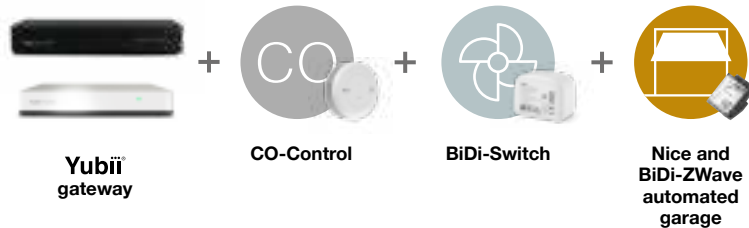

**Home comfort:** the garage door and gate close, the lights turn off, the blinds are lowered, and the temperature is automatically adjusted. When you return, everything is reactivated: lights turn on, blinds are raised, and the temperature is set to a comfortable level.

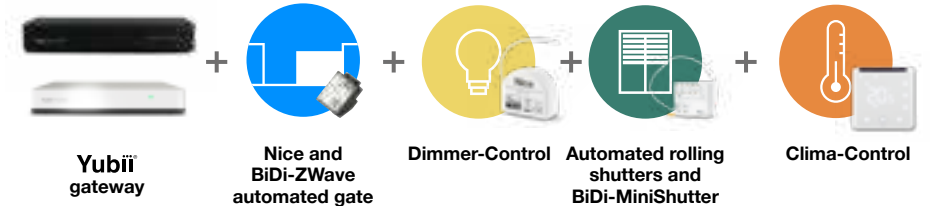

DISCOVER HOW TO USE OUR SOLUTIONS

**The Nice Smart Home system:**  
easy and wireless, integrable and flexible, secure and always in control.

View the full catalogue of Smart Home solutions →



Nice

# BiDi-ZWave

Plug-in interface for communicating between the Z-Wave™ gateway and Nice motors.

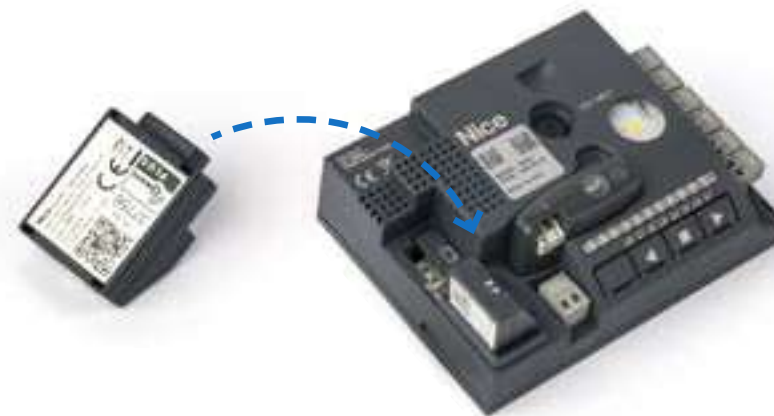

**BiDi-ZWave can be installed on Nice automations with BUS T4 connector to integrate and manage them through any Z-Wave™.**

**Easy to install:** plug-in interface, no programming required.

With BiDi-ZWave, through the app and the home's Z-Wave™ gateway, you can:

- **access the IoT functions**, the app will suggest the actions to be performed based on the information gathered from the user's habits;
- **manage automations using voice commands**;
- **obtain support for automation diagnostics and maintenance**, report the presence of anomalies or problems and suggest the measures to be taken.

DESIGNED FOR  
END CONSUMERS



### Yubii Home App

By using your smartphone and the Yubii Home app, you can manage all your Smart Home automations and Z-Wave devices wherever you are.



### Voice Commands

Managing the home's automations is even easier, including from your smart watch or the car's infotainment system via Amazon Alexa or Google Assistant.



### TECHNICAL SPECIFICATIONS

Code	Description	Pcs. Pack
<b>BIDI-ZWAVE</b>	Z-Wave plug-in interface	1

Code	<b>BIDI-ZWAVE</b>
Power supply	24V supplied by the control unit to which the BiDi-ZWAVE - IBT4ZWAVE is connected
Current draw (mA)	maximum 50
Radio transmission (MHz)	868,0 - 868,6 / 869,7 - 870,0
Antenna cable length (m)	1 / 3
Protection class (IP)	40
Operating temperature (°C Min/Max)	-20 ÷ +50
Dimensions (mm)	37x 28xh21
Weight (g)	10

Z-Wave

BUS T4

**Gate Scenario: Morning Routine**



Have a good day! Do you want to open the gate?

YES | NO



**Gate Scenario: Hazard Prevention**

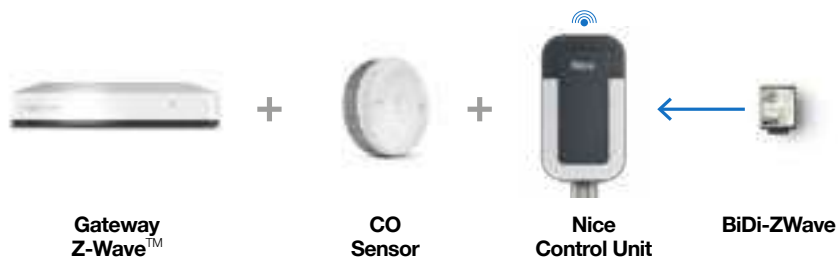

Possible danger: there is a higher level of CO in this zone. - Do you want to open the garage door?

YES | NO

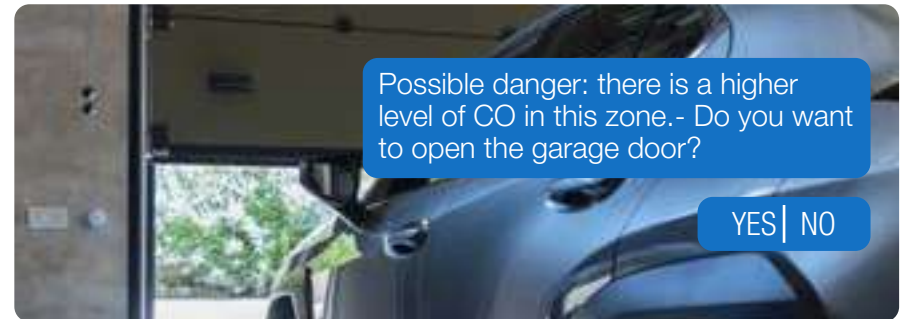

**Gate&Door Scenario: Voice Commands**

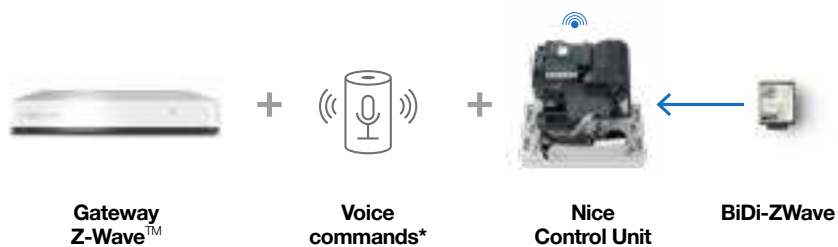

"Hey Google, open the gate"



**Gate Scenario: Automation Diagnostics**

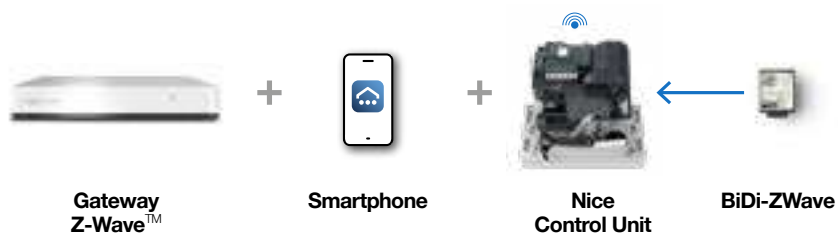

Please check whether the photocells are obstructed

Check for obstacles between the photocells



\*Voice commands via Siri through the Apple Shortcuts app, via Alexa and Google through their respective speakers and speaker apps.

Nice

# BiDi-WiFi

Pocket-sized programming interface for controlling Nice automations by smartphone.

Also available in a KIT



Wi-Fi

BUS T4

## Voice Commands

Managing the home's automations is even easier, including from your smart watch or the car's infotainment system via Amazon Alexa or Google Assistant.



**BiDi-WiFi is the** easy, pocket-sized plug-in interface, compatible with all Nice automations for gates and garage doors with Bus-T4 connector.



**BiDi-WiFi and the MyNice Pro programming app make installation configuration easy and efficient.**

### Programme the automation: plug in, set up and go.

Once plugged into the control unit, the BiDi-WiFi interface **automatically generates a Wi-Fi network that allows the automation to be configured** via the **MyNice Pro** app, so all automation programming steps can also be carried out from the comfort of your own vehicle.

### Control the system easily.

Procedures guided by a **wizard with a description of the parameters displayed** as in the instruction manual. The **search function** lets you easily find the parameter you want to programme to complete the installation.

**Dedicated cloud** management. You can consult an overview of **interventions, geolocation** via map and **statistics**, to guarantee your customers a fast and efficient service and rapid response times.

### Firmware update

By recognising the Gate&Door control unit, Nice technology lets you **update the firmware** and **view manuals** to easily access information on the automation throughout the intervention.



**BiDi-WiFi and the MyNice app allow the gate and garage door to be controlled locally or remotely with a smartphone or via a voice assistant, without a gateway.**

### Nice ProConnect.

When BiDi-WiFi is connected to the Nice cloud, via the MyNice app, the end user can enable the installer to manage the automation remotely, setting the times and authorisation level; full or partial automation management.

If enabled, the installer can intervene remotely via the MyNice Pro app, according to the authorisation received.

## TECHNICAL SPECIFICATIONS

Code	Description	Pcs. Pack
<b>BiDi-WiFi</b>	Pocket programming interface	1



### BiDi-WiFi is also available in the following kit:

<b>BIDI-WIFI EXT</b>	1 BiDi-WiFi + 1 IBT4EXT + 1 BusT4 cable + 1 IBT4N	1	<b>CE</b>
----------------------	---	---	-----------

Code	<b>BIDI-WIFI</b>
Power supply	12-24V
Max. power draw (W)	1,2
Wi-Fi interface with internal antenna	802.11b/g/n – 2.4GHz client / AP (P < 20 dBm EIRP)
WIFI Safety	OPEN/WEP/WPA-PSK/WPA2-PSK
Protection class (IP)	40
Operating temperature (°C Min/Max)	-20 ÷ +50
Dimensions (mm)	43.9 x 27.5 x 21h
Weight (g)	15

Nice

# BiDi-WiFi Ext

Extends Wi-Fi connectivity for Nice automations beyond the Wi-Fi coverage area.



The **BiDi-WiFi Ext** kit combines the **BiDi-WiFi interface** and **IBT4EXT adapter** to provide fast, stable, and extended Wi-Fi connection — up to **100 m range** — for any control unit with a **BusT4** or **IBT4N** input.

Compact and plug-and-play, it requires no additional power supply and offers a reliable, future-ready solution to manage Nice automations with the **MyNice Pro app**, **MyNice app** and connect it to the **Yubii ecosystem**.

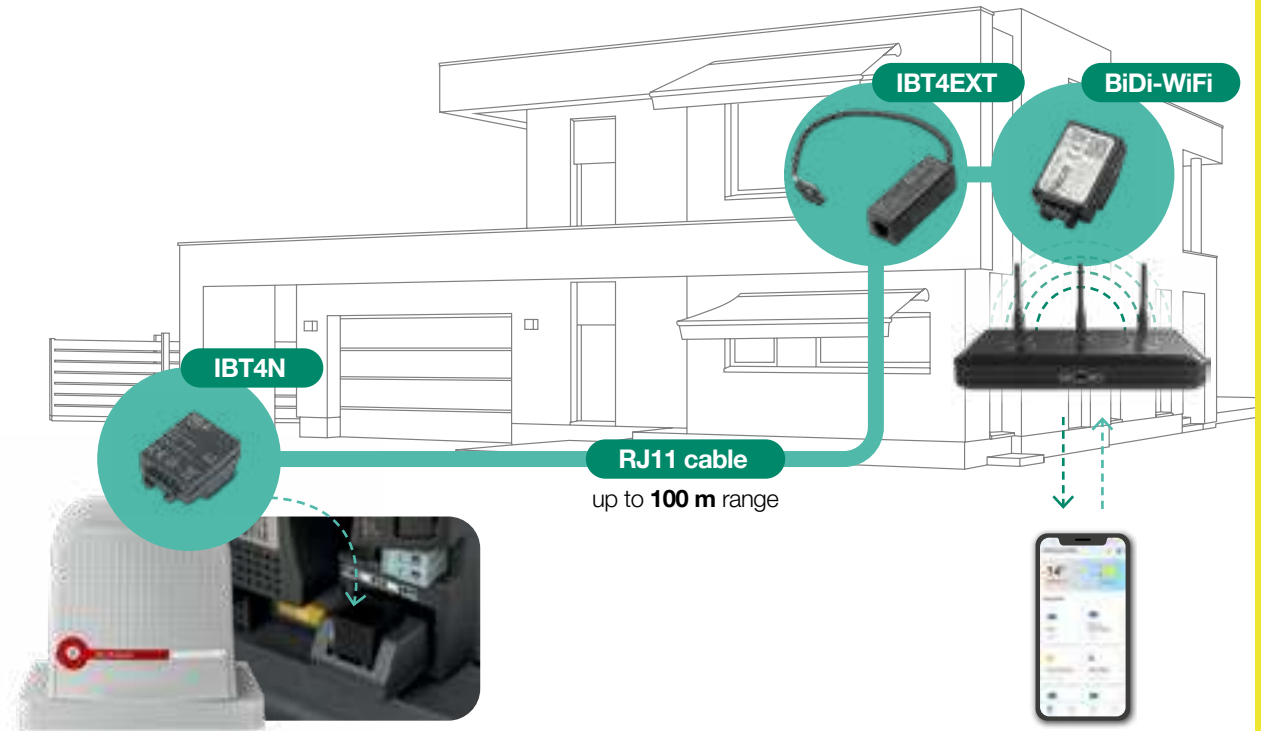

DESIGNED FOR  
END CONSUMERS



GET IT ON  
Google Play

Download on the  
App Store

## MyNice App



Control gates and garage doors by smartphone, with reliable connection even beyond Wi-Fi range.



DESIGNED FOR  
INSTALLERS



GET IT ON  
Google Play

Download on the  
App Store

## MyNice Pro App



Configure and assist remotely, ensuring reliable connection at all times.



Nice

# Pro-View

## Simplified installation.

Thanks to Pro-View and the MyNice Pro App, you can install devices easily even while sitting comfortably in your vehicle.

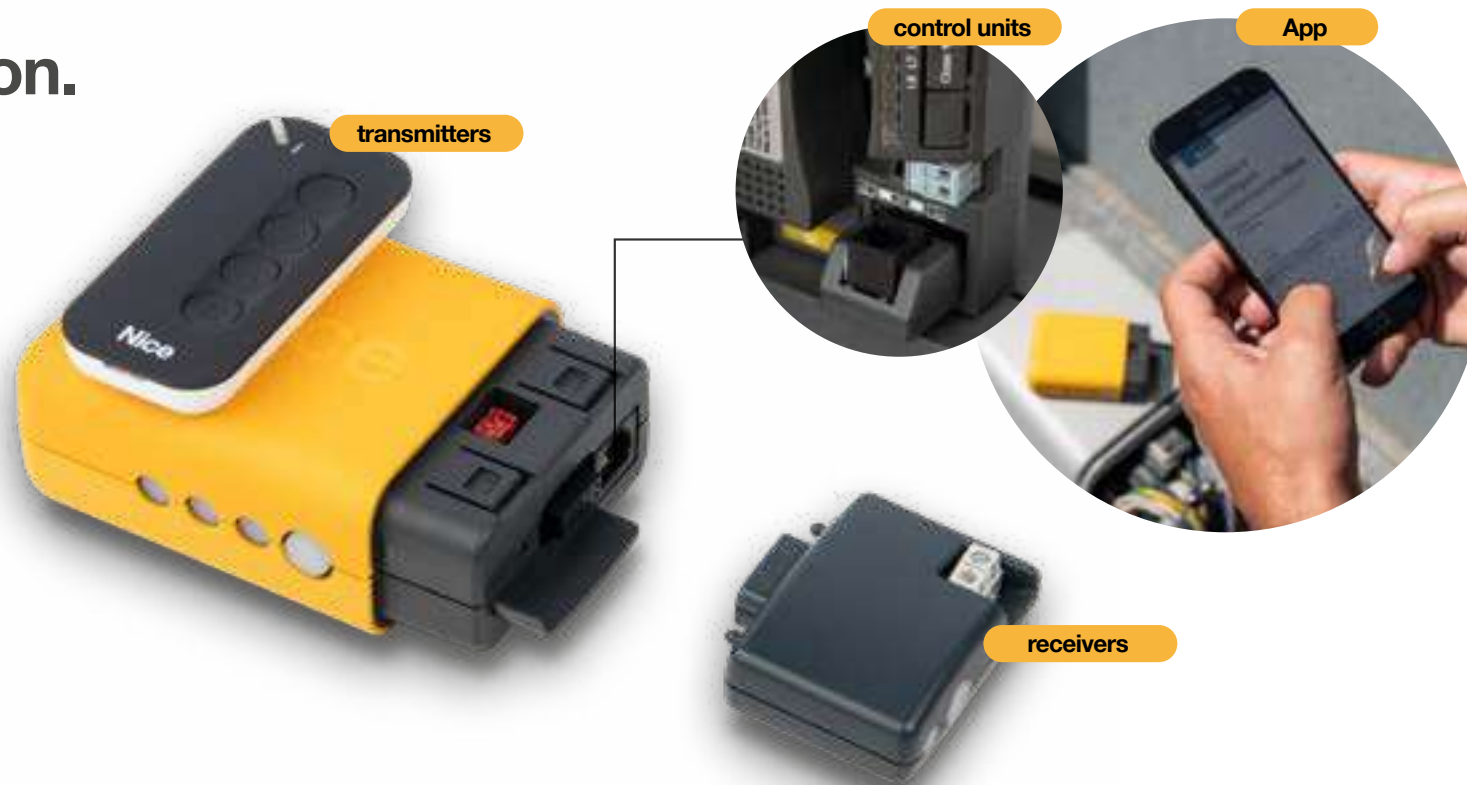

### Rapid user-friendly App

Procedures guided by a wizard with a description of the parameters displayed as in an instruction manual.



### Remote control management tool

Rapid programming, multi-user dashboard and the possibility of creating a database of your installations.



### Management cloud for your activity

Statistics and geolocation of installations to optimise the work of the entire team.



### Simplified viewing of manuals

Access the manual of the automation you are programming in real time.



### Real time firmware updates

Check for available updates while working on the automation.

## MyNice Pro App

Allows Nice installers to work on automations directly from their smartphones via the Pro-View multifunction interface.

**One tool, a great many functions,** with the MyNice Pro App you can:

- set up the automation following the guided programming procedure;
- set and manage all the configuration parameters;
- manage accessories such as transmitters;
- view diagnostics, manage programming remotely and also provide remote assistance;
- save the last configuration backup of the control unit and/or receiver on the Nice Cloud, store the backup on your device and call up the saved information whenever you want; access product documentation rapidly;
- create, geolocate and manage the installation remotely via an intuitive dashboard, add a photograph of the installation;
- automatically recognise the automation system, update the control unit firmware and download the instruction manual.

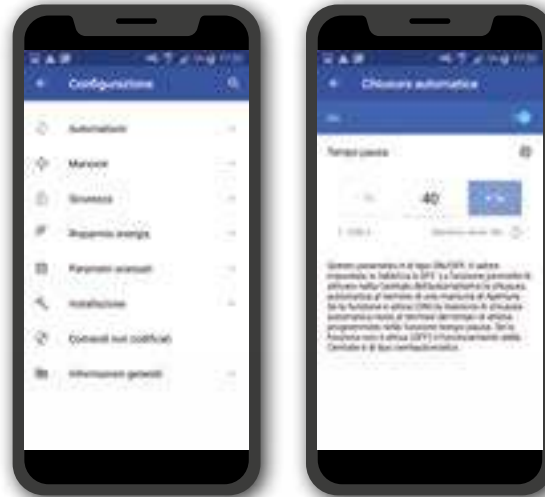

### Main features

---

**Intuitive interface**

---

**Fast and easy search functions**

---

**Detailed description of functions**

---

**Programme backup and restore**

---

## Nice Cloud

**Massima efficienza e rapidità di gestione del lavoro.**

Attraverso la sezione dedicata all'installatore sul Cloud Nice è possibile:

- visualizzare tutte le installazioni effettuate;
- visualizzare tutti gli interventi effettuati;
- visualizzare le foto dell'installazione;
- il profilo amministratore può gestire ulteriori utenti che possono utilizzare tutte le funzioni, per avere sempre sotto controllo lo stato degli interventi di tutto il team di lavoro.



Nice

# Pro-View

**Multifunction interface**, for connection to Nice control units by BUS T4, enables Nice automation systems to be installed and configured by smartphone via the MyNice Pro App.



Handy and compact,  
2 hours operating time

Sturdy and resistant:  
special protective case



#### IBT4N

Interface for connecting the Pro-View programming unit and IT4WIFI smart interface.

BiDi

BUS T4

OXIBD

Easy  
Installation



SCAN ME

**Pro-View is conceived to give professionals a new generation tool** to make their work easier. Its numerous functions also simplify installation.

**Advantageous:** via the MyNice Pro App and Nice Cloud, installers can configure the automation simply and intuitively following the guided programming procedure, control the status of accessories, create and manage a database of their installations with absolute safety, monitor the status of the systems at all times, manage programming remotely and also provide customers with remote assistance.

#### Advanced:

- Nice bidirectional protocol to access and programme the new Nice bidirectional receivers and transmitters;
- functions of the traditional O-View and Obox tools.

#### With Pro-View, you can also:

- programme via radio One series unidirectional and bidirectional transmitters and Inti;
- manage via WiFi all functions of One series unidirectional and bidirectional transmitters and Inti with built-in transmitter.

#### TECHNICAL SPECIFICATIONS

Code	Description	Pcs. Pack
<b>Pro-View</b>	Multifunction interface	1

Code	Pro-View
Input	5V microUSB connector
Optional battery power	2x AA NiMh rechargeable
Maximum power draw (W)	1,5
Wi-Fi interface with internal antenna	802.11b/g/n – 2.4 GHz (P<10mW)
Safety	OPEN/WEP/WPA-PSK/WPA2-PS
Interfaces	T4
Dual-band radio transmission	Bidirectional dual band 433.54 - 433.92 MHz / 868.3 - 868.94 MHz (P<10mW)
Protection class (IP)	30
Operating temperature (°C Min/Max)	-20 ÷ +50
Dimensions (mm)	113x64x33
Weight (g)	100

\* Transmitter range and receiver reception capacity may be affected by any other devices operating on the same frequency in the area and by the position of the system's radio antenna.

#### ACCESSORIES

Code	Description	Pcs. Pack
<b>CABLA06</b>	Cable for programming OXI series universal receivers	1

# Hi-Speed Faster than Ever.

The series of fast automations for swing and sliding gates and now also for garage doors:  
**Nice cuts waiting times!**

## High-speed motors

The perfect solution where rapid opening and closing manoeuvres are required, ensuring the shortest waiting time and maximum comfort.  
**Nice, for your peace of mind.**

## A versatile range

A complete offer to meet a range of installation requirements, characterised by **precision and reliability** thanks to the obstacle detection technology. Ideal in residential, commercial and industrial applications.



## 100% safety

Thanks to the advanced technology of Nice control units and the safety devices, Hi-Speed line automation systems are synonymous with efficiency, reliability and comfort, in full compliance with European standards.

Nice

# Toona HS

**For fast operation of swing gates  
with leaves up to 5 m or 400 kg (TO5024HS)  
and up to 6 m or 1450 kg (TO6024HS).**

Ideal for residential and industrial applications.

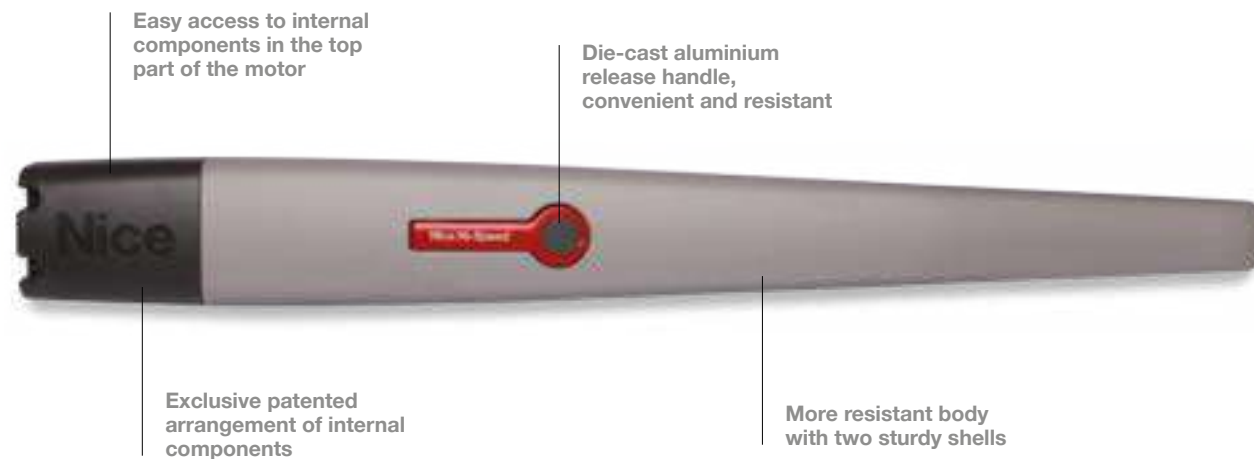

Electromechanical gearmotor, surface mounted, 24 VDC with magnetic encoder.

**Guarantees fast manoeuvres:** 90° opening in about 16\* seconds for TO5024HS and about 30\* seconds for TO6024HS.

**Reliable:** the magnetic encoder keeps the set values stable over time and guarantees precise obstacle detection.

**Quiet:** patented arrangement of internal components and bronze screw.

**Sturdy:** thanks to the body made up of two robust polyester painted aluminium shells; more weather-resistant.

Moving internal parts made entirely of steel, light alloys and technopolymers.

**Large, practical connection compartment:** quick and easy access from above to the internal components located in the upper compartment of the motor.

**Easy installation and maintenance:** with built-in condenser.

**Moonclever MC824H control unit.**

\* Considering standard installation, excluding acceleration and deceleration.

BlueBus

BiDi

Programmable via  
App

24V

Yubii

With Pro-View or  
Bidi-WiFi & MyNice  
Pro App.

Solemyo

Opera



Code	Description	Pcs./Pallet
<b>TO5024HS</b>	Non-reversible, 24 VDC, fast, with magnetic encoder, mechanical stop in opening and closing	20
<b>TO6024HS</b>	Non-reversible, 24 VDC, fast, with magnetic encoder, mechanical stop in opening and closing	20

**COMMON ACCESSORIES**

Code	Description	Pcs. Pack
<b>PSS324</b>	24 V battery with integrated battery charger	1
<b>PLA10</b>	Vertical 12 V electric lock (obligatory for leaves longer than 3 m)	1
<b>PLA11</b>	Horizontal 12 V electric lock (obligatory for leaves longer than 3 m)	1
<b>PLA16</b>	Articulated rear bracket	1
<b>SYKCE30</b>	Solar power supply kit consisting of SYP30 photovoltaic panel, PSY24 battery box with charging control circuit and SYA1 charger	1
<b>TS</b>	Sign	1

Find out more on page → 46.

**TECHNICAL SPECIFICATIONS**

Code	TO5024HS	TO6024HS
<b>ELECTRICAL SPECIFICATIONS</b>		
Power supply (VDC)	24	
Draw (A)	5	
Power (W)	120	
<b>PERFORMANCE DATA</b>		
Speed (m/s)	>> 0,025 <<	>> 0,016 <<
Force (N)	1800	2200
Working cycle (cycles/hour)	95	41
<b>DIMENSIONAL AND GENERAL DATA</b>		
Protection class (IP)	44	
Operating temperature (°C Min/Max)	-20 ÷ +50	
Dimensions (mm)	965x115x105 h	1200x128x150 h
Weight (kg)	7,5	15

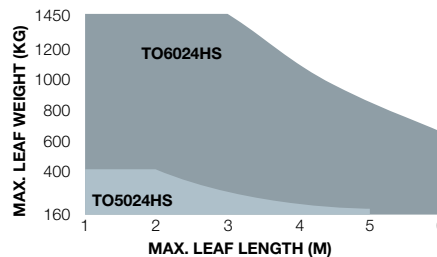
**OPERATING LIMITS**

The shape and height of the gate and presence of a strong wind can considerably reduce the values shown in the graph. The 230 VAC models are best for windy areas.

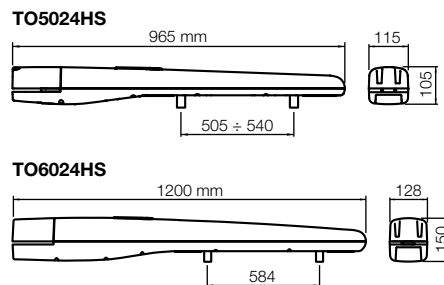
**DIMENSIONS****COMPATIBILITY WITH CONTROL SYSTEMS AND ACCESSORIES**

TO5024HS  
TO6024HS

**Control unit/Receiver****Integrated\***

- • OXIBD / OXILR

**Transmitter**

- • ERA INTI - 2 channels, 433.92 MHz, different colours
- • ERA ONE / MYGO - 2, 4 or 8 channels, 433.92 MHz
- • MYGOBD / ERA ONE LR
- • DOMi

**Photocells**

EPS - Slim / EPM - Medium / EPL - Large

- • EPSB - Slim, BlueBUS / EPMB - Medium, BlueBUS / EPLB - Large, BlueBUS
- • EPMOR - Medium, reflective
- • EPMORB - Medium, BlueBUS, reflective
- • EPMOW - Medium, wireless self-synchronised

F210 - Synchronised, adjustable / FT210 - For sensitive edges

- • F210B - BlueBUS

FT210B - For sensitive edges, BlueBUS

**Flashing light****ELAC**

- • ELDC
- • WLT - Multifunction LED light

\* Radio receiver not compatible with the O-box functions of the Opera system.

Nice

# Wingo HS

**For fast operation of swing gates with leaves up to 3 m or 200 kg.**

Ideal for residential applications.



Also available in a KIT



Practical key release

Exclusive patented arrangement of internal components

BlueBus

BiDi

Programmable via App

24V

Yubii

With Pro-View or Bidi-WiFi & MyNice Pro App.

Solemyo

Opera



Electromechanical gearmotor, surface mounted, 24 VDC with magnetic encoder.

**Guarantees fast manoeuvres:** 90° opening in about 10\* seconds.

**Reliable:** the magnetic encoder keeps the set values stable over time and guarantees precise obstacle detection.

**Quiet:** patented arrangement of internal components and fewer moving parts.

**Easy to install:** electrical connections from above, with gearmotor mounted.

**Mechanical limit switches:** pre-mounted in opening.

**Moonclever MC824H control unit.**

\* Considering standard installation, excluding acceleration and deceleration.

Code	Description	Pcs./Pallet
<b>WG3524HS</b>	Non-reversible, 24 VDC, fast, with magnetic encoder, mechanical stop in opening and closing	15
<b>WINGO3524HSSBDKCE</b>	Kit for automating swing gates with leaves up to 3 m, 24 VDC, surface mounted, with bidirectional technology. The kit contains WG3524HS, 1 x MC824H, 2 x MYGO4, 1 x BIDI-WIFI, 1 x EPMB, 1 x ELDC, 1 x TS.	15



#### The WINGO3524HSSBDKCE kit contains:

Code	Description	Quantity
<b>MC824H</b>	Moonclever control unit	1
<b>MYGO4</b>	4-channel 433.92 MHz transmitter	2
<b>BIDI-WIFI</b>	Plug-in interface for communication between Z-Wave gateway and Nice motors	1
<b>EPMB</b>	Pair of surface mounted photocells with provision for connection via Nice BlueBUS	1
<b>ELDC</b>	Flashing LED light with integrated antenna	1
<b>TS</b>	Sign	1

N.B. The contents of the pack may vary: always consult the dealer.

#### COMMON ACCESSORIES

Code	Description	Pcs. Pack
<b>PSS324</b>	24 V battery with integrated battery charger	1
<b>PLA14</b>	Screw-on adjustable rear bracket	2
<b>PLA15</b>	Screw-on adjustable front bracket	2
<b>PLA10</b>	Vertical 12 V electric lock	1
<b>PLA11</b>	Horizontal 12 V electric lock	1
<b>SYKCE30</b>	Solar power supply kit consisting of SYP30 photovoltaic panel, PSY24 battery box with charging control circuit and SYA1 charger	1
<b>TS</b>	Sign	1

Find out more on page → 46.

#### TECHNICAL SPECIFICATIONS

Code	WG3524HS
<b>ELECTRICAL SPECIFICATIONS</b>	
Power supply (VDC)	24
Draw (A)	5
Power (W)	120
<b>PERFORMANCE DATA</b>	
Speed (m/s)	>> 0,04 <<
Force (N)	1500
Working cycle (cycles/hour)	30
<b>DIMENSIONAL AND GENERAL DATA</b>	
Protection class (IP)	44
Operating temperature (°C Min/Max)	-20 ÷ +50
Dimensions (mm)	920x98x95 h
Weight (kg)	6

#### OPERATING LIMITS

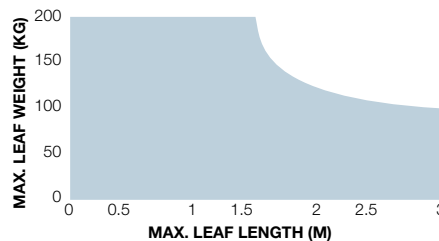

#### DIMENSIONS

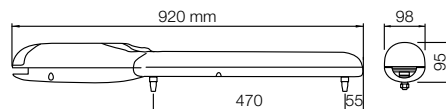

#### COMPATIBILITY WITH CONTROL SYSTEMS AND ACCESSORIES

WG3524HS

##### Control unit/Receiver

###### Integrated\*

- MC824H / OXIBD / OXILR

###### Transmitter

- ERA INTI - 2 channels, 433.92 MHz, different colours
- ERA ONE / MYGO - 2, 4 or 8 channels, 433.92 MHz
- MYGOBD / ERA ONE LR
- DOMI

###### Photocells

EPS - Slim / EPM - Medium / EPL - Large

- EPSB - Slim, BlueBUS / EPMB - Medium, BlueBUS / EPLB - Large, BlueBUS

EPMOR - Medium, reflective

- EPMORB - Medium, BlueBUS, reflective
- EPMOW - Medium, wireless self-synchronised

F210 - Synchronised, adjustable / FT210 - For sensitive edges

- F210B - BlueBUS

FT210B - For sensitive edges, BlueBUS

###### Flashing light

###### ELAC

- ELDC

- WLT - Multifunction LED light

\* Radio receiver not compatible with the O-box functions of the Opera system.

Nice

# Titan HS

**For rapid operation of swing gates with leaves up to 3.7 m (TTN3724HS, TTN3724RHSS), 6 m (TTN6024HS, TTN6024RHS) or 450 kg.**



Easy access to internal components in the top part of the motor

Practical key release

Electromechanical gearmotor, surface mounted, 24 VDC with magnetic encoder.

**Guarantees fast manoeuvres:** 90° opening in about 12\* seconds with TTN3724HS and TTN3724RHS or 19\* seconds with TTN6024HS and TTN6024HS.

\* Considering standard installation, excluding acceleration and deceleration.

**Reliable:** the magnetic encoder keeps the set values stable over time and guarantees precise obstacle detection.

**Easy to install:** electrical connections easily accessible from above, thanks to the dedicated input. The fixing brackets are supplied with the motor.

**Versatile:** the motor can also be installed in the bottom part of the gate leaf, at a distance of at least 110 mm from the ground.

**Practical and safe:** the convenient key release located in the top part of the motor allows the gate leaves to be opened and closed manually in the event of a blackout.

**Models TTN3724HS and TTN6024HS are compatible with the Moonclever MC824H control unit, while models TTN3724RHS and TTN6024RHS are compatible with the MC824HR control unit \*\*.**

\*\* Not compatible with the SYKCE30 solar power kit.

BlueBus

BiDi

Programmable via App

24V

Yubii

With Pro-View or Bidi-WiFi & MyNice Pro App.

Solemyo

Opera



Code	Description	Pcs./Pallet
<b>TTN3724HS</b>	Non-reversible, 24 VDC, fast, with magnetic encoder, for swing gates with leaves up to 3.7 m or 450 kg	32
<b>TTN3724RHS</b>	Reversible, 24 VDC, fast, with magnetic encoder, for swing gates with leaves up to 3.7 m or 450 kg	32
<b>TTN6024HS</b>	Non-reversible, 24 VDC, fast, with magnetic encoder, for swing gates with leaves up to 6 m or 450 kg	32
<b>TTN6024RHS</b>	Reversible, 24 VDC, fast, with magnetic encoder, for swing gates with leaves up to 6 m or 450 kg	32

## COMMON ACCESSORIES

Code	Description	Pcs. Pack
<b>PSS324</b>	24 V battery with integrated battery charger	1
<b>PLA10</b>	Vertical 12 V electric lock (obligatory for leaves longer than 3 m)	1
<b>PLA11</b>	Horizontal 12 V electric lock (obligatory for leaves longer than 3 m)	1
<b>SYKCE30</b>	Solar power supply kit consisting of SYP30 photovoltaic panel, PSY24 battery box with charging control circuit and SYA1 charger	1
<b>TS</b>	Sign	1

Find out more on page → 46.

## TECHNICAL SPECIFICATIONS

Code	TTN3724HS	TTN6024HS	TTN3724RHS	TTN6024RHS
<b>ELECTRICAL SPECIFICATIONS</b>				
Power supply (VDC)	24			
Draw (A)	6	7	6	7
Power (W)	150		170	
<b>PERFORMANCE DATA</b>				
Speed (m/s)	>> 0,032 <<	>> 0,027 <<	>> 0,032 <<	>> 0,027 <<
Force (N)	1900			
Working cycle (cycles/hour)	continuous cycle			
<b>DIMENSIONAL AND GENERAL DATA</b>				
Protection class (IP)	54			
Operating temperature (°C Min/Max)	-20 ÷ +55			
Dimensions (mm)	910x105x170 h	1080x105x170 h	910x105x170 h	1080x105x170 h
Weight (kg)	8	9	8	9
L max / L min / stroke (mm)	1370 / 860 / 510	1710 / 1030 / 680	1370 / 860 / 510	1710 / 1030 / 680
WxH (mm)	105x170			

## OPERATING LIMITS

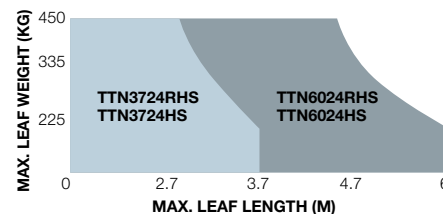

The shape and height of the gate and presence of a strong wind can considerably reduce the values shown in the graph.

## DIMENSIONS

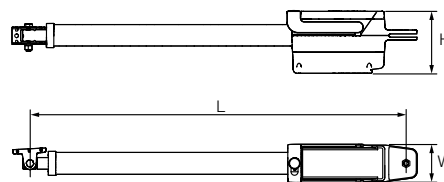

## COMPATIBILITY WITH CONTROL SYSTEMS AND ACCESSORIES

TTN3724HS TTN3724RHS TTN6024HS TTN6024RHS	Control unit/Receiver
	<b>Integrated*</b>
• •	MC824H / OXIBD / OXILR
• •	MC824HR / OXIBD / OXILR
	<b>Transmitter</b>
• • • •	ERA INTI - 2 channels, 433.92 MHz, different colours
• • • •	ERA ONE / MYGO - 2, 4 or 8 channels, 433.92 MHz
• • • •	MYGOBD / ERA ONE LR
• • • •	DOMi
	<b>Photocells</b>
	EPS - Slim / EPM - Medium / EPL - Large
• • • •	EPSB - Slim, BlueBUS / EPMB - Medium, BlueBUS / EPLB - Large, BlueBUS
	EPMOR - Medium, reflective
• • • •	EPMORB - Medium, BlueBUS, reflective
• • • •	EPMOW - Medium, wireless self-synchronised
	F210 - Synchronised, adjustable / FT210 - For sensitive edges
• • • •	F210B - BlueBUS
	FT210B - For sensitive edges, BlueBUS
	<b>Flashing light</b>
	ELAC
• • • •	ELDC
• • • •	WLT - Multifunction LED light

\* Radio receiver not compatible with the O-box functions of the Opera system.

Nice

# Hyke HS

**For fast operation of swing gates with leaves up to 3 m or 270 kg.**

Ideal for residential applications, including with large posts.

Electromechanical gearmotor with articulated arm, surface mounted, 24 VDC, with magnetic encoder.

**Ideal for intensive use and fast manoeuvres:** 90° opening in about 10\* seconds.

**Powerful and reliable:** thanks to the 500 Nm torque and encoder technology, for millimetric accuracy and reliability.

**Safe movement:** double technology obstacle detection.

**Sturdy:** thanks to the polyester painted aluminium body; more weather-resistant.

**Two non-reversible, 24 VDC** versions with opening and closing limit switches: with integrated control unit (HK7024) or without control unit (HK7224).

**Quick and practical installation:** the length of the articulated arm can be adjusted for maximum flexibility.

**Simple and precise limit switch adjustment:** mechanical stops and micrometric adjustment screws.

**No blackouts:** operation in event of power failure with the optional batteries (PSS124) housed in the motor.

**Integrated control unit (HK7024).**

\* Considering standard installation, excluding acceleration and deceleration.



BlueBus

BiDi

Programmable via App

24V

Yubii

With Pro-View or Bidi-WiFi & MyNice Pro App.

Solemyo

Opera



Code	Description	Pcs./Pallet
<b>HK7024HS</b>	Non-reversible, 24 VDC, fast, with magnetic encoder, complete with articulated arm and integrated control unit	12
<b>HK7224HS</b>	Non-reversible, 24 VDC, fast, complete with articulated arm, without integrated control unit	12

#### COMMON ACCESSORIES

Code	Description	Pcs. Pack
<b>SPHKA2R30</b>	Spare control unit for HK7024HS	1
<b>PSS124</b>	24 V battery with integrated battery charger	1
<b>PLA10</b>	Vertical 12 V electric lock	1
<b>PLA11</b>	Horizontal 12 V electric lock	1
<b>KIO</b>	Key switch for low-voltage contacts, with release mechanism for metal cable	1
<b>KA1</b>	Kit with 6 m metal cable for KIO	1
<b>SYKCE30</b>	Solar power supply kit consisting of SYP30 photovoltaic panel, PSY24 battery box with charging control circuit and SYA1 charger	1
<b>TS</b>	Sign	1

Find out more on page → 46.

#### TECHNICAL SPECIFICATIONS

Code	HK7024HS	HK7224HS
<b>ELECTRICAL SPECIFICATIONS</b>		
Power supply (VAC 50/60HZ)	230	-
Power supply (VDC)	-	24
Draw (A)	1,5	6
Power (W)	300	140
Power in Stand-by (W)	<0,25	
<b>PERFORMANCE DATA</b>		
Speed (rpm)	>> 2 <<	
Torque (Nm)	500	
Working cycle (cycles/hour)	40	
<b>DIMENSIONAL AND GENERAL DATA</b>		
Protection class (IP)	54	
Operating temperature (°C Min/Max)	-20 ÷ +50	
Dimensions (mm)	290x210x320 h	
Weight (kg)	10,5	9,5

#### OPERATING LIMITS

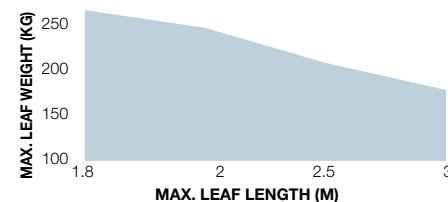
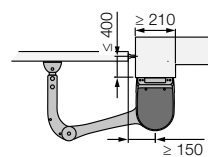

The shape and height of the gate and presence of a strong wind can considerably reduce the values shown in the graph.

#### DIMENSIONS

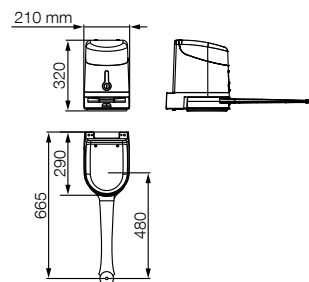

#### COMPATIBILITY WITH CONTROL SYSTEMS AND ACCESSORIES

HK7024HS

##### Control unit/Receiver

Integrated\*

- OXIBD / OXILR

##### Transmitter

- ERA INTI - 2 channels, 433.92 MHz, different colours
- ERA ONE / MYGO - 2, 4 or 8 channels, 433.92 MHz
- MYGOBD / ERA ONE LR

- DOMi

##### Photocells

EPS - Slim / EPM - Medium / EPL - Large

- EPSB - Slim, BlueBUS / EPMB - Medium, BlueBUS / EPLB - Large, BlueBUS

EPMOR - Medium, reflective

- EPMORB - Medium, BlueBUS, reflective

- EPMOW - Medium, wireless self-synchronised

F210 - Synchronised, adjustable / FT210 - For sensitive edges

- F210B - BlueBUS

FT210B - For sensitive edges, BlueBUS

##### Flashing light

ELAC

- ELDC

- WLT - Multifunction LED light

\* Radio receiver not compatible with the O-box functions of the Opera system.

Nice

# M-Fab HS

**For fast operation of swing gates with leaves up to 3 m or 300 kg.**

Concealed underground installation, ideal for residential applications.

Reliable and resistant



Waterproof, IP67 protection class

FAB BOX foundation boxes

Electromechanical gearmotor, 24 VDC, with magnetic encoder.

**Ideal for intensive use and fast manoeuvres:** 90° opening in about 8\* seconds.

\* Considering standard installation, excluding acceleration and deceleration.

**Moulded Fab Box** foundation boxes with mechanical stop in opening:

- **in stainless steel** (MFABBOXI), ideal for use in extreme conditions;
- **electrophoretic painted** (MFABBOX), with high resistance to corrosion.

**Reliable and resistant:** motors with solid metal internal components. New IP67 waterproof die-cast aluminium.

**Maximum freedom of choice:** release from inside and outside, two freely combinable key or lever-operated models, easy to operate with one hand.

**Simple installation:** mechanical stop system in closing. Standard 110° opening, 360° optional.

**Totally compatible** with the previous Metro series.

**Moonclever MC824H control unit.**

BlueBus

BiDi

Programmable via App

24V

Yubii

With Pro-View or Bidi-WiFi & MyNice Pro App.

Solemyo

Opera



Code	Description	Pcs./Pallet
<b>MFAB3024HS</b>	Non-reversible, 24 VDC, fast, with magnetic encoder, complete with connecting lever and mechanical stop in closing	18
Code	Description	Pcs./Pallet
<b>MFABBOXI</b>	Externally chamfered stainless steel foundation box with mechanical stop in opening	20
<b>MFABBOX</b>	Electrophoretic painted, externally chamfered foundation box with mechanical stop in opening	20

**NOTE:** key release freely combinable, choosing between models MEA2 and MEA3.

#### COMMON ACCESSORIES

Code	Description	Pcs. Pack
<b>PSS324</b>	24 V battery with integrated battery charger	1
<b>MEA2</b>	Key release	1
<b>MEA3</b>	Lever key release for use when installing on surfaces such as sand or earth	1
<b>MEA5</b>	Lever key for release	4
<b>MEA6</b>	Limit bracket, for installations where the foundation box cannot be embedded in concrete	4
<b>MEA1</b>	Accessory for opening up to 360° for leaves up to 2.5 m long	4
<b>PLA10</b>	Vertical 12 V electric lock	1
<b>PLA11</b>	Horizontal 12 V electric lock	1
<b>SYKCE30</b>	Solar power supply kit consisting of SYP30 photovoltaic panel, PSY24 battery box with charging control circuit and SYA1 charger	1
<b>TS</b>	Sign	1

Find out more on page → 46.

#### TECHNICAL SPECIFICATIONS

Code	<b>MFAB3024HS</b>
ELECTRICAL SPECIFICATIONS	
Power supply (VDC)	24
Draw (A)	6
Power (W)	170
PERFORMANCE DATA	
Speed (rpm)	>> 2,6 <<
Torque (Nm)	180
Working cycle (cycles/hour)	80
DIMENSIONAL AND GENERAL DATA	
Protection class (IP)	67
Operating temperature (°C Min/Max)	-20 ÷ +50
Dimensions (mm)	390x322x194 h
Weight (kg)	11

#### OPERATING LIMITS

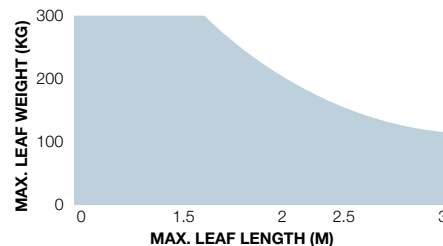

The shape and height of the gate and presence of a strong wind can considerably reduce the values shown in the graph.

#### DIMENSIONS

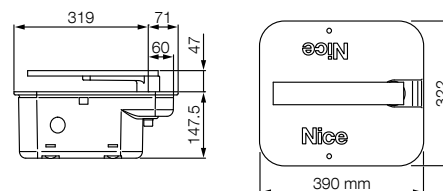

#### COMPATIBILITY WITH CONTROL SYSTEMS AND ACCESSORIES

MFAB3024HS

##### Control unit/Receiver

Integrated\*

- OXIBD / OXILR

##### Transmitter

- ERA INTI - 2 channels, 433.92 MHz, different colours
- ERA ONE / MYGO - 2, 4 or 8 channels, 433.92 MHz
- MYGOBD / ERA ONE LR

- DOMI

##### Photocells

- EPS - Slim / EPM - Medium / EPL - Large
- EPSB - Slim, BlueBUS / EPMB - Medium, BlueBUS / EPLB - Large, BlueBUS
- EPMOR - Medium, reflective
- EPMORB - Medium, BlueBUS, reflective
- EPMOW - Medium, wireless self-synchronised

**F210** - Synchronised, adjustable / **FT210** - For sensitive edges

- **F210B** - BlueBUS
- **FT210B** - For sensitive edges, BlueBUS

##### Flashing light

##### ELAC

- ELDC
- WLT - Multifunction LED light

\* Radio receiver not compatible with the O-box functions of the Opera system.

Nice

# L-Fab HS

**For fast operation of swing gates with leaves up to 4 m or 400 kg.**

Concealed underground installation.

Reliable and resistant



Waterproof, IP67 protection class

Electromechanical gearmotor, 24 VDC, with magnetic encoder and mechanical stops.

**Ideal for intensive use and fast manoeuvres:** 90° opening in about 6\* seconds.

**Foundation boxes** with mechanical stop in opening:

- **in stainless steel** (LFABBOX4I), ideal for use in extreme conditions;
- **electrophoretic painted** (LFABBOX4), with high resistance to corrosion.

**Maximum freedom of choice:** lever release from inside and outside, freely combinable and easy to operate with one hand.

**Simple installation:** mechanical stop system in closing. Standard 110° opening, 360° optional.

**Ideal for intensive use, the LFAB4024HS model is compatible with the Moonclever MC824H control unit, with BlueBUS technology and provision for Solemyo and Opera systems.**

\* Considering standard installation, excluding acceleration and deceleration.

BlueBus

BiDi

Programmable via App

24V

Yubii

With Pro-View or Bidi-WiFi & MyNice Pro App.

Solemyo

Opera



Code	Description	Pcs./Pallet
<b>LFAB4024HS</b>	Non-reversible, 24 VDC, fast, with magnetic encoder and mechanical limit switch in closing	18
Code	Description	Pcs./Pallet
<b>LFABBOX4</b>	Electrophoretic painted foundation box with mechanical limit switch in opening. Complete with leaf attachment lever	18
<b>LFABBOX4I</b>	Stainless steel foundation box with mechanical limit switch in opening. Complete with leaf attachment lever	18

**NOTE:** key release freely combinable, choosing between models MEA2 and MEA3.

#### COMMON ACCESSORIES

Code	Description	Pcs. Pack
<b>PSS324</b>	24 V battery with integrated battery charger	1
<b>BMA3</b>	Release with lever key	1
<b>MEA5</b>	Lever key for release	4
<b>BMA1</b>	Accessory for opening up to 360° for leaves up to 3.5 m long	1
<b>PLA10</b>	Vertical 12 V electric lock	1
<b>PLA11</b>	Horizontal 12 V electric lock	1
<b>SYKCE30</b>	Solar power supply kit consisting of SYP30 photovoltaic panel, PSY24 battery box with charging control circuit and SYA1 charger	1
<b>TS</b>	Sign	1

Find out more on page → 46.

#### TECHNICAL SPECIFICATIONS

Code	<b>LFAB4024HS</b>
ELECTRICAL SPECIFICATIONS	
Power supply (VDC)	24
Draw (A)	7
Power (W)	170
PERFORMANCE DATA	
Speed (rpm)	<b>&gt;&gt; 3 &lt;&lt;</b>
Torque (Nm)	200
Working cycle (cycles/hour)	50**
DIMENSIONAL AND GENERAL DATA	
Protection class (IP)	67
Operating temperature (°C Min/Max)	-20 ÷ +55
Dimensions (mm)	375x225x110 h*
Weight (kg)	12,5

\* With foundation box. \*\* The value indicated must be halved in the case of opening up to 180° - using the BMA1 accessory.

<b>Foundation box</b>	<b>LFABBOX4</b>
Weight (kg)	14,4

#### OPERATING LIMITS

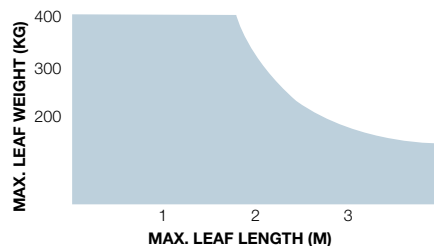

The shape and height of the gate and presence of a strong wind can considerably reduce the values shown in the graph.

#### DIMENSIONS

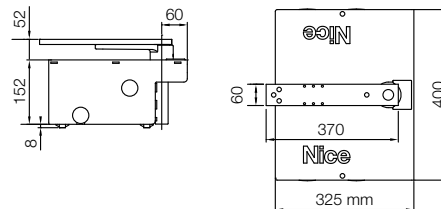

#### COMPATIBILITY WITH CONTROL SYSTEMS AND ACCESSORIES

LFAB4024HS

##### Control unit/Receiver

Integrated\*

- OXIBD / OXILR

##### Transmitter

- ERA INTI - 2 channels, 433.92 MHz, different colours
- ERA ONE / MYGO - 2, 4 or 8 channels, 433.92 MHz
- MYGOBD / ERA ONE LR

- DOMI

##### Photocells

- EPS - Slim / EPM - Medium / EPL - Large
- EPSB - Slim, BlueBUS / EPMB - Medium, BlueBUS / EPLB - Large, BlueBUS
- EPMOR - Medium, reflective
- EPMORB - Medium, BlueBUS, reflective
- EPMOW - Medium, wireless self-synchronised

**F210** - Synchronised, adjustable / **FT210** - For sensitive edges

- **F210B** - BlueBUS
- **FT210B** - For sensitive edges, BlueBUS

##### Flashing light

##### ELAC

- ELDC
- WLT - Multifunction LED light

\* Radio receiver not compatible with the O-box functions of the Opera system.

Nice

# Robus 600 HS

For the rapid operation of sliding gates weighing up to 600 kg.



Available in a KIT

New control units with built-in Wi-Fi, quick and easy programming via the MyNice Pro app



Housings for optional adjustable photocell and LED lights

Eye Check

**Non-reversible, 24 VDC, magnetic limit switch, control unit with built-in radio receiver**, compatible with optional buffer battery (PSS124).

**Ideal for intensive use:** a 4 m gate opens in less than 10\* seconds.

**Efficient and safe:** functional mechanical design and high-performance materials.

**Safe and easy-to-use release lever; magnetic limit switch**, easy to install and allows for shorter rack length.

**Easy to programme** thanks to the MyNice Pro app, connecting the control unit to the Pro-View or BiDi-WiFi.

## Easy to install:

- control unit with integrated receiver in raised position;
- maximum freedom in horizontal and vertical base adjustment.
- BlueBUS **connector** allows connections with just two wires between the control unit and up to 7 pairs of photocells and control, safety and signalling devices;
- expandable control unit with accessory modules to increase the number of inputs or outputs;
- fastening backwardcompatible with previous Nice models (Rox, Road, Robus series).

## Smart:

- self-teaching work times;
- control slowdown, speed and force;
- self-diagnosis with status of automation and accessories signalled via the new **Eye Check system**.

**Always connected** even remotely, thanks to the built-in Wi-Fi or the BIDI-ZWAVE plug-in module.

*\* In a standard installation, excluding acceleration and deceleration.*



NICE GREEN  
INNOVATION

EPD®

IES-0011924

BlueBus

24V

BUS T4

BiDi

Yubii

Solemyo

Opera

Programmable via App

With Pro-View or BiDi-WiFi & MyNice Pro App.



Code	Description	Pcs./Pallet
<b>RBS600HS</b>	Non-reversible, 24 VDC, fast, with integrated control unit, magnetic limit switch, for gates weighing up to 600 kg	30
<b>RBS600HSBDKCE</b>	Kit for automating a sliding gate up to 600 kg. Non-reversible electro-mechanical gearmotor, 24 VDC, fast, with control unit and integrated receiver. The kit contains RBS600HS, 2 x MYGO4, 1 x EPMB, 1 x ELDC, 1 x TS	18
<b>RBS600HSBDKLT</b>	Kit for automating a sliding gate up to 600 kg. Non-reversible electro-mechanical gearmotor, 24 VDC, fast, with control unit and integrated receiver. The kit contains RBS600HS, 2 x MYGO4, 1 x TS	30

N.B. Pack contents may vary: always consult the dealer.



#### The RBS600HSBDKCE kit contains:

Code	Description	Quantity
<b>RBS600HS</b>	Non-reversible electromechanical gearmotor, 24 VDC, fast, with control unit and integrated receiver, for gates weighing up to 600 kg	1
<b>MYGO4</b>	4-channel 433.92 MHz transmitter	2
<b>EPMB</b>	Pair of surface-mounted photocells compatible with BlueBUS connection	1
<b>ELDC</b>	Flashing LED light with integrated antenna	1
<b>TS</b>	Safety sign	1



#### The RBS600HSBDKLT kit contains:

Code	Description	Quantity
<b>RBS600HS</b>	Non-reversible electromechanical gearmotor, 24 VDC, fast, with control unit and integrated receiver, for gates weighing up to 600 kg	1
<b>MYGO4</b>	4-channel 433.92 MHz transmitter	2
<b>TS</b>	Safety sign	1

#### COMMON ACCESSORIES

Code	Description	Pcs. Pack
<b>SPMCU2</b>	Spare control unit for RBS600HS with built-in Wi-Fi	1
<b>MLAE21</b>	Plug-in expansion board 1 Output 2 Input	1
<b>MLAE22</b>	Plug-in expansion board 2 Output (1 230V Relay) 2 Input	1
<b>MLAE44</b>	Plug-in expansion board 4 Output 4 Input	1
<b>ROA6</b>	Slotted rack, M4 25x20x1000 mm, nylon with metal insert. For gates up to 500 kg	10
<b>ROA66</b>	Slotted nylon rack M4 25x20x1000 mm with metal core, six fastening points. For gates weighing up to 800 kg	10
<b>ROA7</b>	Galvanised rack, M4 22x22x1000 mm	10
<b>ROA8</b>	Galvanised rack, M4 30x8x1000 mm, with screws and spacers	10
<b>PSS124</b>	24 V battery with integrated battery charger	1
<b>SYKCE30</b>	Solar power supply kit consisting of SYP30 photovoltaic panel, PSY24 battery box with charging control circuit and SYA1 charger	1
<b>RBSKITSAFE1</b>	Courtesy light and photocell support kit	1

#### TECHNICAL SPECIFICATIONS

Code	RBS600HS
<b>ELECTRICAL SPECIFICATIONS</b>	
Power supply (VAC 50/60 Hz)	230
Draw (A)	3,1
Power (W)	450
Standby power (W)	1,5
<b>PERFORMANCE DATA</b>	
Speed (m/s)	>> 0,44 <<
Force (N)	600
Working cycle (cycles/hour) 4 m leaf	40
<b>DIMENSIONAL AND GENERAL DATA</b>	
Protection class (IP)	44
Operating temperature (°C Min/Max)	-20 ÷ +50
Dimensions (mm)	340x220x303 h
Weight (kg)	11

#### DIMENSIONS

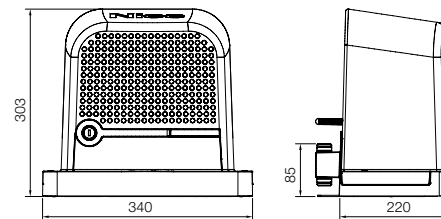

#### COMPATIBILITY WITH CONTROL SYSTEMS AND ACCESSORIES

RBS600HS

##### Control unit/Receiver

- Integrated\*
- OXIBD / OXILR

##### Transmitter

- ERA INTI - 2 channels, 433.92 MHz, different colours
- ERA ONE / MYGO - 2, 4 or 8 channels, 433.92 MHz
- MYGOBD / ERA ONE LR

##### • DOMI

##### Photocells

- EPS - Slim / EPM - Medium / EPL - Large
- EPSB - Slim, BlueBUS / EPMB - Medium, BlueBUS / EPLB - Large, BlueBUS
- EPMOR - Medium, reflective
- EPMORB - Medium, BlueBUS, reflective
- EPMOW - Medium, wireless self-synchronised
- F210 - Synchronised, adjustable / FT210 - For sensitive edges

- F210B - BlueBUS

##### Flashing light

- ELAC
- ELDC
- WLT - Multifunction LED light

\* Radio receiver not compatible with the O-box functions in the Opera system

Nice

# Robus HS

**For fast operation of sliding gates up to 250 kg (RB250HS).**

For residential and industrial applications.

Compartment for control unit protected by pull-out box



Base and release in epoxy-painted die-cast aluminium

RB250HS

24 VDC electromechanical gearmotor.

**Ideal for intensive use:** a 4 m gate takes about 10\* seconds to open with RB250HS.

**Simple:** thanks to the BlueBUS system allowing connections with just two wires between the control unit and up to 7 pairs of photocells and control, safety and signalling devices.

**Practical:** control unit and PSS124 buffer batteries (optional) connected by practical guided plug-in connector, housed in the gearmotor.

**Advanced:** the temperature sensor adapts the motor force to the climatic conditions while at the same time adjusting the thermal protection; a master/slave selection also automatically synchronises 2 motors, allowing automation of sliding gates with two opposing leaves.

A master/slave selection also automatically synchronises 2 motors, allowing automation of sliding gates with two opposing leaves.

**Smart:** thanks to obstacle detection and automatic programming of operating times. Self-diagnostics with indications via the flashing light. 8 programming levels.

**Safe:** adjustable acceleration and deceleration at the start and end of each manoeuvre.

**Sturdy:** release with aluminium handle for easy opening.

**Quiet:** gearmotor on bearings.

\* Considering standard installation, excluding acceleration and deceleration.

BlueBus

BiDi

Programmable via App

24V

Yubii

With Pro-View or Bidi-WiFi & MyNice Pro App.

Solemyo

Opera



Code	Description	Pcs./Pallet
<b>RB250HS</b>	Non-reversible, 24 VDC, fast, with integrated control unit, electromechanical limit switch, for gates up to 250 kg	14

**COMMON ACCESSORIES**

Code	Description	Pcs. Pack
<b>SPRBA3HSR10</b>	Spare control unit for RB250HS	1
<b>PSS124</b>	24 V battery with integrated battery charger	1
<b>RBA1</b>	Inductive limit switch	1
<b>ROA6</b>	Slotted rack, M4 25x20x1000 mm, nylon with metal insert. For gates up to 500 kg	10
<b>ROA66</b>	Slotted nylon rack M4 25x20x1000 mm with metal core and six clear fastening points. For gates weighing up to 800 kg	10
<b>ROA7</b>	Galvanised rack, M4 22x22x1000 mm	10
<b>ROA8</b>	Galvanised rack, M4 30x8x1000 mm, with screws and spacers	10
<b>SYKCE30</b>	Solar power supply kit consisting of SYP30 photovoltaic panel, PSY24 battery box with charging control circuit and SYA1 charger	1
<b>TS</b>	Sign	1

Find out more on page → 47.

**TECHNICAL SPECIFICATIONS**

Code	<b>RB250HS</b>
<b>ELECTRICAL SPECIFICATIONS</b>	
Power supply (VAC 50/60 Hz)	230
Draw (A)	2,1
Power (W)	430
<b>PERFORMANCE DATA</b>	
Speed (m/s)	>> 0,4 <<
Force (N)	310
Working cycle (cycles/hour)	50
<b>DIMENSIONAL AND GENERAL DATA</b>	
Protection class (IP)	44
Operating temperature (°C Min/Max)	-20 ÷ +50
Dimensions (mm)	330x195x277 h
Weight (kg)	8

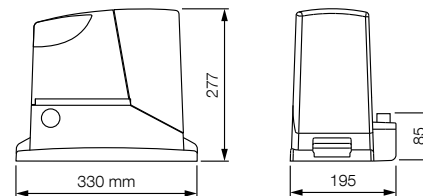
**DIMENSIONS****RB250HS****COMPATIBILITY WITH CONTROL SYSTEMS AND ACCESSORIES****RB250HS****Control unit/Receiver****Integrated\***

- **OXIBD / OXILR**

**Transmitter**

- **ERA INTI** - 2 channels, 433.92 MHz, different colours
- **ERA ONE / MYGO** - 2, 4 or 8 channels, 433.92 MHz
- **MYGOBD / ERA ONE LR**

- **DOMI**

**Photocells**

- **EPS** - Slim / **EPM** - Medium / **EPL** - Large
- **EPSB** - Slim, BlueBUS / **EPMB** - Medium, BlueBUS / **EPLB** - Large, BlueBUS
- **EPMOR** - Medium, reflective
- **EPMORB** - Medium, BlueBUS, reflective
- **EPMOW** - Medium, wireless self-synchronised

**F210** - Synchronised, adjustable / **FT210** - For sensitive edges

- **F210B** - BlueBUS
- **FT210B** - For sensitive edges, BlueBUS

**Flashing light****ELAC**

- **ELDC**
- **WLT** - Multifunction LED light

\* Radio receiver not compatible with the O-box functions of the Opera system.

Nice

# Run HS

**For fast operation of sliding gates up to 1200 kg (RUN1200HS).**

For residential and industrial applications.



Compartment for control unit  
protected by pull-out box

Base and release  
in epoxy-painted  
die-cast aluminium

24 VDC electromechanical gearmotor.

**Fast opening and closing manoeuvres:** 4 m gate in about 6\* seconds, while RUN1200HS opens a 7 m gate in about 18\* seconds.

**The fastest:** ideal for heavy-duty industrial applications.

**Simple:** thanks to the BlueBUS system allowing connections with just two wires between the control unit and up to 7 pairs of photocells and control, safety and signalling devices.

**Practical:** control unit and PS524 battery charger (for connection of two B12-B batteries) housed in the gearmotor, connected by practical guided plug-in connector.

**Advanced:** the temperature sensor adapts the motor force to the climatic conditions while at the same time adjusting the thermal protection; a master/slave selection also automatically synchronises 2 motors, allowing automation of sliding gates with two opposing leaves.

**Smart:** thanks to obstacle detection and automatic programming of operating times.

Self-diagnostics with indications via the flashing light. 8 programming levels.

**Safe:** adjustable acceleration and deceleration at the start and end of each manoeuvre.

**Sturdy:** release with aluminium handle for easy opening.

**Quiet:** gearmotor on bearings.

\* Considering standard installation, excluding acceleration and deceleration.

BlueBus

BiDi

24V

Yubii

Opera

**Programmable via App**

With Pro-View or Bidi-WiFi & MyNice Pro App.



Code	Description	Pcs./Pallet
<b>RUN1200HS</b>	Non-reversible, 24 VDC, fast, with integrated control unit, electromechanical limit switch, for gates up to 1200 kg	12

**COMMON ACCESSORIES**

Code	Description	Pcs. Pack
<b>SPRUA6</b>	Spare control unit for RUN1200HS	1
<b>B12-B</b>	12 V, 6 Ah battery	1
<b>PS524</b>	Charge card for 7 Ah batteries	1
<b>RBA1</b>	Inductive limit switch	1
<b>ROA7</b>	Galvanised rack, M4 22x22x1000 mm	10
<b>ROA8</b>	Galvanised rack, M4 30x8x1000 mm, with screws and spacers	10
<b>ROA81</b>	Galvanised rack M6 30x30x1000 mm, weld-on, for use with RUA12 crown	10
<b>RUA12</b>	12-tooth crown, module 6, for use with ROA81 rack. Run is supplied with a module 4 crown to use standard ROA7 and ROA8 racks	1
<b>TS</b>	Sign	1

Find out more on page → 47.

**TECHNICAL SPECIFICATIONS**

Code	RUN1200HS
<b>ELECTRICAL SPECIFICATIONS</b>	
Power supply (VAC 50/60 Hz)	230
Draw (A)	2
Power (W)	415
<b>PERFORMANCE DATA</b>	
Speed (m/s)	>> 0,37 <<
Force (N)	790
Working cycle (cycles/hour)	60
<b>DIMENSIONAL AND GENERAL DATA</b>	
Protection class (IP)	44
Operating temperature (°C Min/Max)	-20 ÷ +50
Dimensions (mm)	400x255x387 h
Weight (kg)	24,5

\* 60 Hz version available on request.

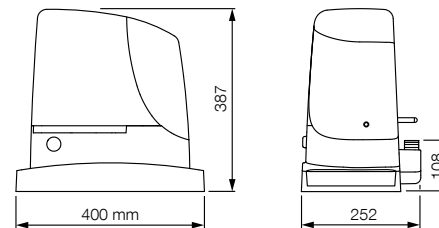
**DIMENSIONS****COMPATIBILITY WITH CONTROL SYSTEMS AND ACCESSORIES**

RUN1200HS

**Control unit/Receiver**

Integrated\*

- OXIBD / OXILR

**Transmitter**

- ERA INTI - 2 channels, 433.92 MHz, different colours

- ERA ONE / MYGO - 2, 4 or 8 channels, 433.92 MHz

- MYGOBD / ERA ONE LR

- DOMI

**Photocells**

EPS - Slim / EPM - Medium / EPL - Large

- EPSB - Slim, BlueBUS / EPMB - Medium, BlueBUS / EPLB - Large, BlueBUS

EPMOR - Medium, reflective

- EPMORB - Medium, BlueBUS, reflective

- EPMOW - Medium, wireless self-synchronised

- F210 - Synchronised, adjustable / FT210 - For sensitive edges

- F210B - BlueBUS

- FT210B - For sensitive edges, BlueBUS

**Flashing light**

ELAC

- ELDC

- WLT - Multifunction LED light

\* Radio receiver not compatible with the O-box functions of the Opera system.

Nice

# Spykit 650 HS BD

For sectional doors up to 10.5 m<sup>2</sup> and up-and-over doors (projecting and non-projecting) up to 11.5 m<sup>2</sup>.



Available in a KIT



BlueBus

24V

BiDi

Yubii

Solemyo

Opera

Programmable via App

With Pro-View or BiDi-WiFi & MyNice Pro App.



Electromechanical gearmotor, non-reversible, 24 VDC for residential use, rack-on-track drive.

To be combined with SPYRAIL321, SPYRAIL162 and SPYRAIL081 rails.

**Guarantees fast manoeuvres:** opens the garage door in about 8.5\* seconds.

**Functional and stylish:** the motor is the only component that moves on the track, no chains or other noisy mechanisms. Ideal for any architectural context.

**Handy:** separate control unit for simpler installation and maintenance. Integrated LED courtesy light. Three practical keys to control the automation.

**Quick to install.** New time-saving solution: wired power supply unit for easy installation in a few simple steps on whichever side of the track you prefer. Limit switches easy to position along the track. No chains or other noisy mechanisms to install.

**Ultra-simple, thanks to the BlueBUS system:** allows connections with just two wires between the control unit and the pairs of photocells and other accessories using BlueBUS technology.

**Easy to programme:** Quick Setup procedure for fast, intuitive basic programming. Simplified advanced programming via Pro-View.

**ON/OFF release system:** pulling the release knob once releases the motor; pulling it a second time blocks the motor again, in any position along the rail.

**Economical and environmentally friendly:** when connected to the mains, the control unit consumes just 0.5 W in standby mode. Connected to the battery or Solemyo kit, consumption in standby mode drops to 0.1 W.

**No blackouts:** operation is guaranteed even without mains power, thanks to the optional PSS324 buffer battery.

**Safe:** obstacle detection, monitoring of motor draw during travel, diagnostic messages via flashing light and courtesy light.

Adjustable acceleration and deceleration at the start and end of each manoeuvre.

Ready for installation of the latest generation 8,2 kOhm resistive sensitive edges.

**Optimised logistics:** to facilitate transport and management, the tracks are available in different sizes: a single 3.2 m section, two tracks each measuring 1.6 m and a 0.8 m extension to add to the other tracks.

\* Considering a typical installation with a 2 m high garage door, excluding acceleration and deceleration.

Code	Description	Pcs./Pallet
<b>SPY650HSBDKCE</b>	Kit for automating sectional and up-and-over doors, 650 N, with SPY-BOXBHS control unit, OXIBD plug-in receiver and 1 MYGO4 transmitter included. Tracks not included	48

**The kit contains:**

Code	Description	Quantity
<b>SPY650HS</b>	Gearmotor 650 N	1
<b>SPYBOXBHS</b>	Control unit with LED courtesy light	1
<b>OXIBD</b>	Plug-in bidirectional radio receiver	1
<b>MYGO4</b>	4-channel 433.92 MHz transmitter	1

N.B. The contents of the pack may vary: always consult the dealer.

**COMMON ACCESSORIES**

Code	Description	Pcs. Pack
<b>SPYLIGHT</b>	LED light module accessory for Spyrail (max 2 per Spyrail)	1
<b>PSS324</b>	24 V battery with integrated battery charger. Requires accessory TNA9 for wall mounting	1
<b>TNA9</b>	Additional connecting cable and supports for wall-mounting the PSS324 battery	1
<b>SPA5</b>	Swing arm sliding on bearings, optimised for projecting up-and-over doors	1
<b>SPA10</b>	Kit with additional ceiling fixing bracket for Spyrail	1
<b>SPA6</b>	Enlarged connecting arm, 585 mm long	1
<b>KI1</b>	Kit for release from outside with metal pull-cord and key ratchet	1
<b>SPA2</b>	Kit for release from outside with metal pull-cord	1
<b>SYKCE30</b>	Solar power supply kit consisting of SYP30 photovoltaic panel, PSY24 battery box with charging control circuit and SYA1 charger	1
<b>TS</b>	Sign	1

Find out more on page → 48.

**TECHNICAL SPECIFICATIONS**

Code	<b>SPY650HSBDKCE</b>
------	----------------------

**ELECTRICAL SPECIFICATIONS**

Power supply (VAC 50/60 Hz)	230 ± 10%
Draw (A)	1,6
Maximum power (W)	300
Power in standby (W)	0,5

**PERFORMANCE DATA**

Maximum speed (m/s)	>> 0,24 <<
Maximum force (N)	650
Nominal force (N)	200
Working cycle (cycles/hour)	30
Working cycle (cycles/day)	300

**DIMENSIONAL AND GENERAL DATA**

Protection class (IP)	IP41
Operating temperature (°C Min/Max)	-20 ÷ +55
Pack dimensions (mm)	380x380x125
Weight (kg)	3,2

**OPERATING LIMITS**

	Non-projecting up-and-over door (with SPA5)		Projecting up-and-over door (with SPA5) or with springs (without SPA5)		Sectional	
	H	W	H	W	H	W
3,2 m track	2,3 m	4 m	2,8 m	4 m	2,5 m	4,2 m
4 m track	3,1 m	3 m	3,5 m	3,3 m	3,3 m	3,2 m

Using maximum travel.

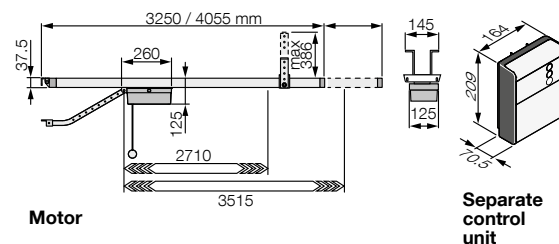
**DIMENSIONS****TECHNICAL SPECIFICATIONS OF TRACKS**

Code	Description	Pcs./Pallet
<b>SPYRAIL321</b>	1 x complete 3,2 m track	48
<b>SPYRAIL162</b>	2 x 1,6 m tracks with assembly accessories	48
<b>SPYRAIL081</b>	0,8 m extension with assembly accessories (to add to the other tracks to reach a length of 4 m)	48

Code	<b>SPYRAIL321</b>	<b>SPYRAIL162</b>	<b>SPYRAIL081*</b>
Type	3,2 m (one section)	3,2 m (2 x 1,6 m sects.)	0,8 m (extension to reach 4 m)
Installed track length (mm)	3270		4075
Useful travel (mm)	2710		3515
Weight (kg)	7,5	8,35	3,3
Pack dimensions (mm)	3230x110x50	1760x110x50	960x110x50
Dimensions accessories pack (mm)	400x400x90		

\* For use in combination with SPYRAIL321 and SPYRAIL162 tracks.

**COMPATIBILITY WITH CONTROL SYSTEMS AND ACCESSORIES****SPYBOXBHS****Control unit/Receiver**

- **Integrated\***
- **OXIBD / OXILR**

**Transmitter**

- **ERA INTI** - 2 channels, 433.92 MHz, different colours
- **ERA ONE / MYGO** - 2, 4 or 8 channels, 433.92 MHz
- **MYGOBD / ERA ONE LR**

**DOMI****Photocells**

- **EPS** - Slim / **EPM** - Medium / **EPL** - Large
- **EPSB** - Slim, BlueBUS / **EPMB** - Medium, BlueBUS / **EPLB** - Large, BlueBUS
- **EPMOR** - Medium, reflective
- **EPMORB** - Medium, BlueBUS, reflective
- **EPMOW** - Medium, wireless self-synchronised
- **F210** - Synchronised, adjustable / **FT210** - For sensitive edges
- **F210B** - BlueBUS
- **FT210B** - For sensitive edges, BlueBUS

**Flashing light**

- **ELAC**
- **ELDC**
- **WLT** - Multifunction LED light

\* Radio receiver not compatible with the O-box functions of the Opera system.

## Accessories for Hi-Speed series swing gates

### COMMON ACCESSORIES



**PLA10**  
Vertical 12 V electric lock (obligatory for leaves longer than 3 m).  
Pcs./pack 1



**PLA11**  
Horizontal 12 V electric lock (obligatory for leaves longer than 3 m).  
Pcs./pack 1



**PLA14**  
Screw-on adjustable rear bracket.  
Pcs./pack 2



**PLA15**  
Screw-on adjustable front bracket.  
Pcs./pack 2



**PLA16**  
Articulated rear bracket (for Toona 4 and 5).  
Pcs./pack 1



**MEA1**  
Accessory for opening up to 360° for leaves up to 2.5 m long.  
Pcs./pack 4



**MEA2**  
Key release.  
Pcs./pack 1



**MEA3**  
Lever key release for use when installing on surfaces such as sand or earth.  
Pcs./pack 1



**MEA5**  
Lever key for release.  
Pcs./pack 4



**MEA6**  
Limit bracket, for installations where the foundation box cannot be embedded in concrete.  
Pcs./pack 4



**BMA3**  
Release with lever key.  
Pcs./pack 1



**BMA1**  
Accessory for opening up to 360° for leaves up to 3.5 m long.  
Pcs./pack 1



**KIO**  
Key switch for low-voltage contacts, with release mechanism for metal cable.  
Pcs./pack 1



**KA1**  
Kit with 6 m metal cable for KIO.  
Pcs./pack 1



**TS**  
Sign.  
Pcs./pack 1

### SPARE CONTROL UNITS



**SPHKA2R30**  
Spare control unit for HK7024.  
Pcs./pack 1

### ACCESSORIES FOR 24 V VERSIONS



**PSS324**  
24 V battery with integrated battery charger.  
Pcs./pack 1



**PSS124**  
24 V battery with integrated battery charger.  
Pcs./pack 1



**SYKCE30**  
Solar power supply kit consisting of SYP30 photovoltaic panel and PSY24 battery box with charging control circuit and SYA1 charger.  
Pcs./pack 1

Solemyo  
24V

# Accessories for Hi-Speed series sliding gates

## RACKS



**ROA6**  
Slotted rack, M4  
25x20x1000 mm, nylon  
with metal insert. For  
gates up to 500 kg.  
Pcs./pack 10



**ROA66**  
Slotted nylon rack M4  
25x20x1000 mm with  
metal core, six fasten-  
ing points. For gates  
weighing up to 800 kg.  
Pcs./pack 10



**ROA7**  
Galvanised rack, M4  
22x22x1000 mm.  
Pcs./pack 10



**ROA8**  
Galvanised rack, M4  
30x8x1000 mm,  
with screws and  
spacers.  
Pcs./pack 10



**ROA81**  
Galvanised rack M6  
30x30x1000 mm, weld-  
on, for use with RUA12  
crown.  
Pcs./pack 10



**RUA12**  
12-tooth crown,  
module 6, for use with  
ROA81 rack.  
Pcs./pack 1



**RBA1**  
Inductive limit switch.  
Pcs./pack 1



**PS524**  
Charge card for 7 Ah  
batteries.  
Pcs./pack 1



**B12-B**  
12 V, 6 Ah battery.  
Pcs./pack 1

## SPARE CONTROL UNITS



**TS**  
Sign.  
Pcs./pack 1



**SPRBA3HSR10**  
Spare control unit for  
RB250HS.  
Pcs./pack 1



**SPRUA6**  
Spare control unit for  
RUN1200HS.  
Pcs./pack 1



**SPMCU2R30**  
Spare control unit for  
RBS600HS.  
Pcs./pack 1



**MLAE21**  
Plug-in expansion  
board 1 Output 2 Input.  
Pcs./pack 1



**MLAE22**  
Plug-in expansion  
board 2 Output (1 230V  
Relay) 2 Input.  
Pcs./pack 1



**MLAE44**  
Plug-in expansion  
board 4 Output 4 Input.  
Pcs./pack 1

## OTHER ACCESSORIES



**RBSKITSAFE1**  
Courtesy light and  
photocell support kit for  
RBS600HS.  
Pcs./pack 1

## ADAPTER PLATES



**CBIPLERB5HS**  
Retrofitting kit replacing  
Nice RB500HS.  
Pcs./pack 1



**CBIPLERB6**  
Retrofitting kit replacing  
Nice RB600.  
Pcs./pack 1

## ACCESSORIES FOR 24 V VERSIONS



**PSS124**  
24 V battery with inte-  
grated battery charger.  
Pcs./pack 1



**SYKCE30**  
Solar power supply kit consisting of SYP30 photo-  
voltaic panel and PSY24 battery box with charging  
control circuit and SYA1 charger.  
Pcs./pack. 1

Solemyo  
24V

## Accessories for Hi-Speed series garage doors

### COMMON ACCESSORIES



**SPYLIGHT**  
LED light module accessory for Spyrail (max 2 per Spyrail).  
Pcs./pack 1



**SPA2**  
Kit for release from outside with metal pull-cord.  
Pcs./pack 1



**SPA5**  
Swing arm sliding on bearings, optimised for projecting up-and-over doors.  
Pcs./pack 1



**SPA6**  
Enlarged connecting arm, 585 mm long.  
Pcs./pack 1



**SPA10**  
Kit with additional ceiling fixing bracket for Spyrail.  
Pcs./pack 1



**KI1**  
Kit for release from outside with metal pull-cord and key ratchet.  
Pcs./pack 1



**PSS324**  
24 V battery with integrated battery charger.  
Pcs./pack 1



**TNA9**  
Additional connecting cable and supports for wall-mounting the PSS324 battery.  
Pcs./pack 1



**TS**  
Sign.  
Pcs./pack 1

### KIT SOLEMYO



Solemyo  
24V

**SYKCE30**  
Solar power supply kit consisting of SYP30 photovoltaic panel and PSY24 battery box with charging control circuit and SYA1 charger.  
Pcs./pack. 1

## Standard installation diagram for Hi-Speed series

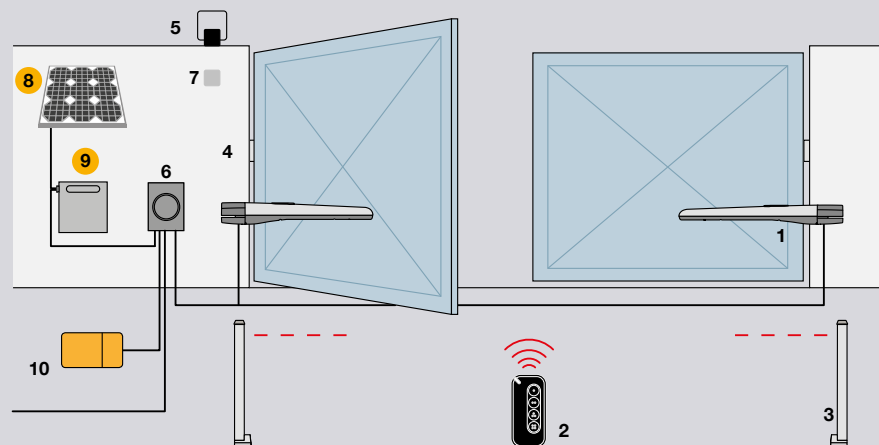

### TOONA HS

1. Motor 2. Transmitter 3. Post-mounted photocells 4. Photocells 5. Flashing light 6. Control unit 7. Key or digital switch 8. SYP30 solar panel 9. PSY24 battery box 10. Pro-View multifunction interface

● Solemyo solar power accessories

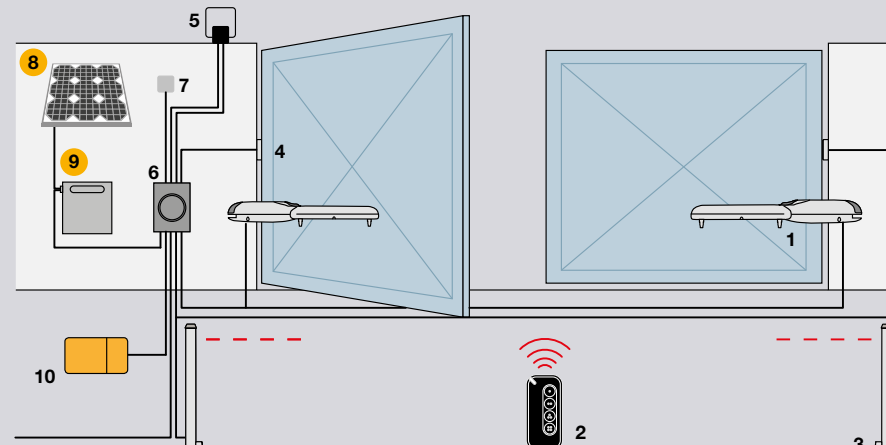

### WINGO HS

1. Motor 2. Transmitter 3. Post-mounted photocells 4. Photocells 5. Flashing light 6. Control unit 7. Key or digital switch 8. Pro-View multifunction interface

● Solemyo solar power accessories

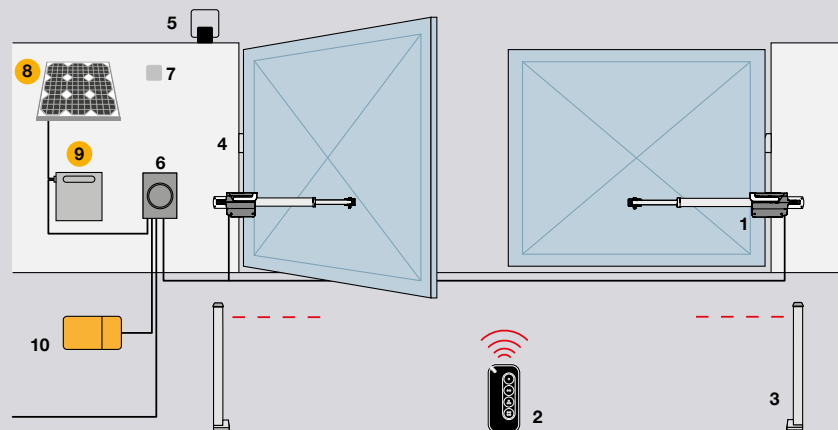

### TITAN HS

1. Motor 2. Transmitter 3. Post-mounted photocells 4. Photocells 5. Flashing light 6. Control unit 7. Key or digital switch 8. SYP30 solar panel 9. PSY24 battery box 10. Pro-View multifunction interface

● Solemyo solar power accessories

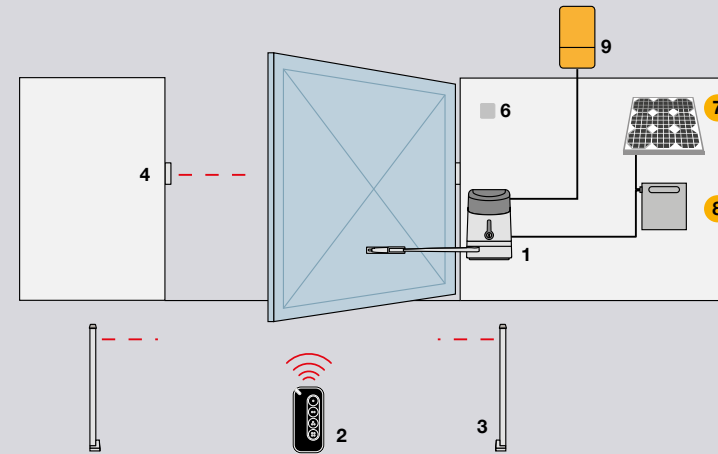
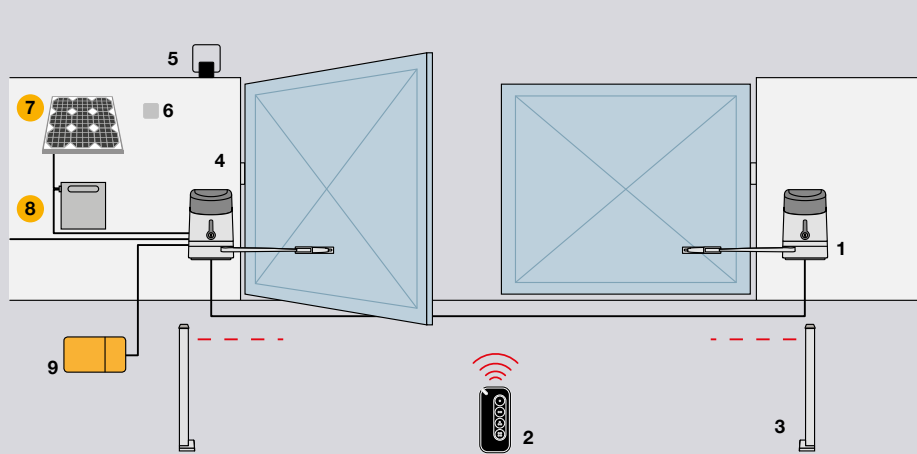

### HYKE HS

1 . Motor 2. Transmitter 3. Post-mounted photocells 4. Photocells 5. Flashing light  
6 . Digital or key switch 7. SYP30 solar panel 8. PSY24 battery box 9. Pro-View multifunction interface (for PP7124 only)

● Solemyo solar power accessories

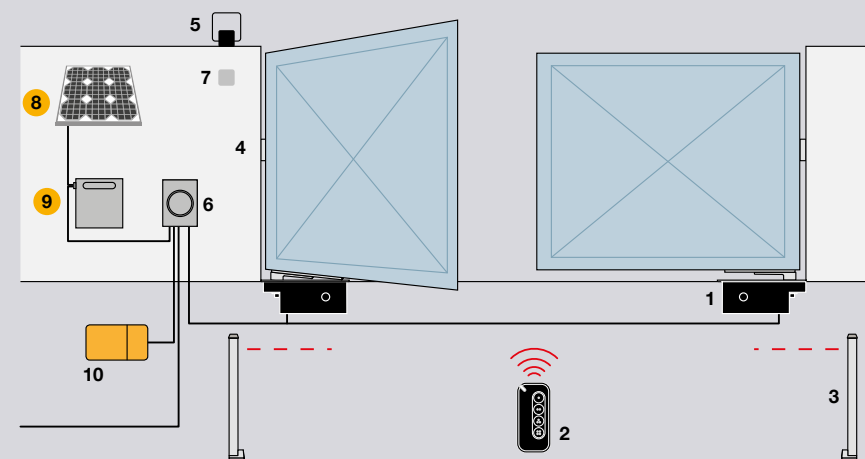
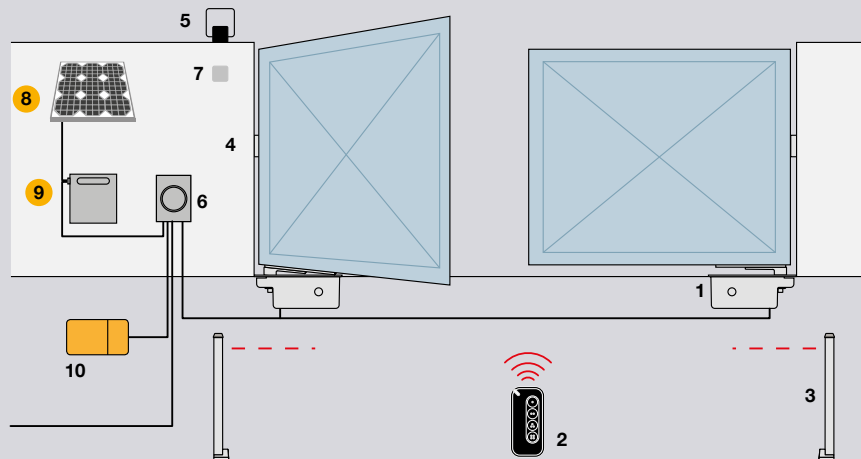

### M-FAB HS

1. Motor 2. Transmitter 3. Post-mounted photocells 4. Photocells 5. Flashing light 6. Control unit 7. Key or digital switch  
8. SYP30 solar panel 9. PSY24 battery box 10. Pro-View multifunction interface

● Solemyo solar power accessories

### L-FAB HS

1. Motor 2. Transmitter 3. Post-mounted photocells 4. Photocells 5. Flashing light 6. Control unit 7. Key or digital switch  
8. SYP30 solar panel 9. PSY24 battery box 10. Pro-View multifunction interface

● Solemyo solar power accessories

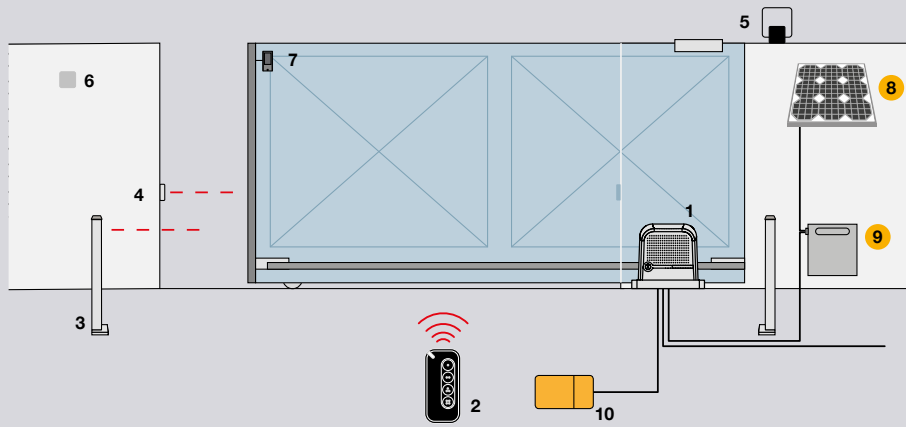

**NEW ROBUS HS / ROBUS HS**

1. Motor 2. Transmitter 3. Post-mounted photocells 4. Photocells 5. Flashing light 6. Key switch 7. Sensor for sensitive edge 8. SYP30 solar panel 9. PSY24 battery box 10. Pro-View multifunction interface

● Solemyo solar power accessories

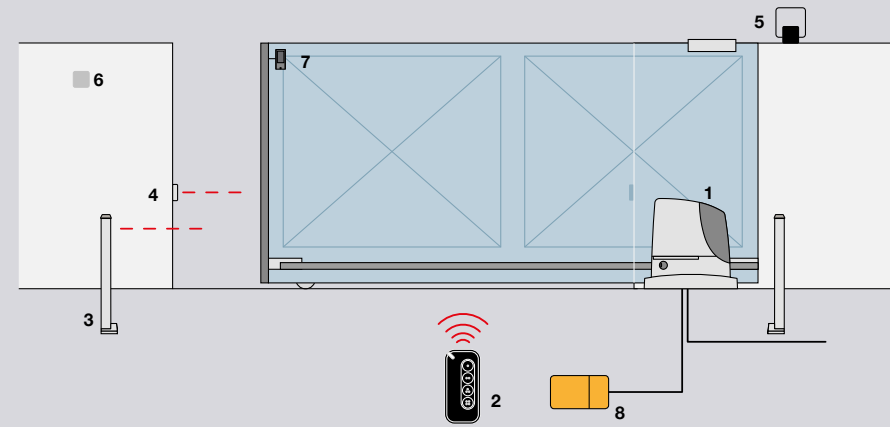

**RUN HS**

1. Motor 2. Transmitter 3. Post-mounted photocells 4. Photocells 5. Flashing light 6. Key switch 7. Sensor for sensitive edge 8. Pro-View multifunction interface

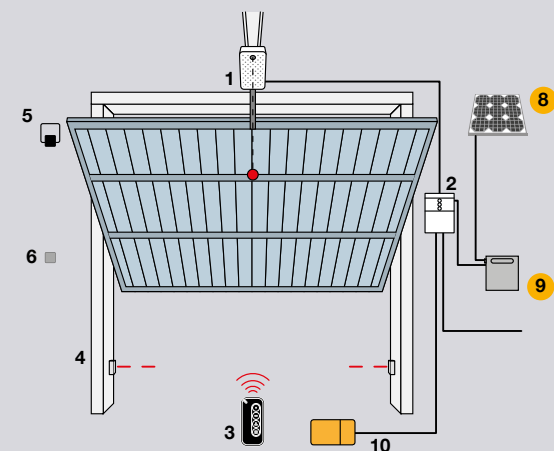
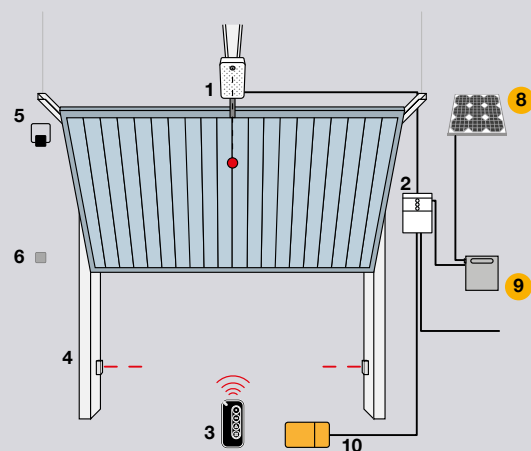
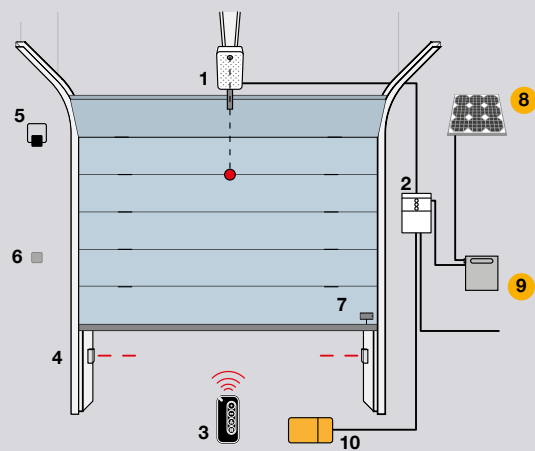

## SPYKIT 650 HS BD

1 . Motor 2. Control unit 3. Transmitter 4. Photocells 5. Flashing light  
6 . Key or digital switch 7. Sensor for sensitive edge 8. SYP30 solar panel 9. PSY24 battery box 10. Pro-View multifunction interface

● Solemyo solar power accessories



# Selection guide

Surface mounted, also available in a kit with bidirectional technology

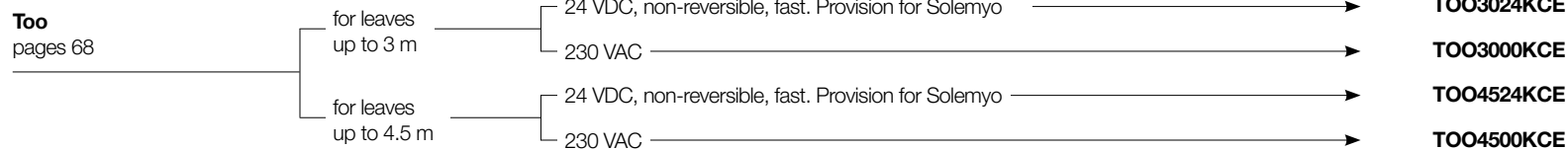
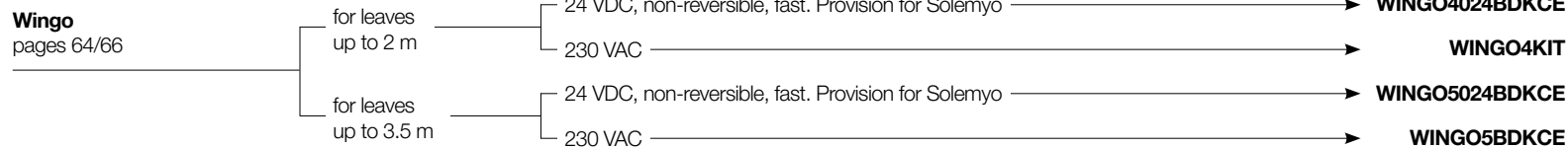
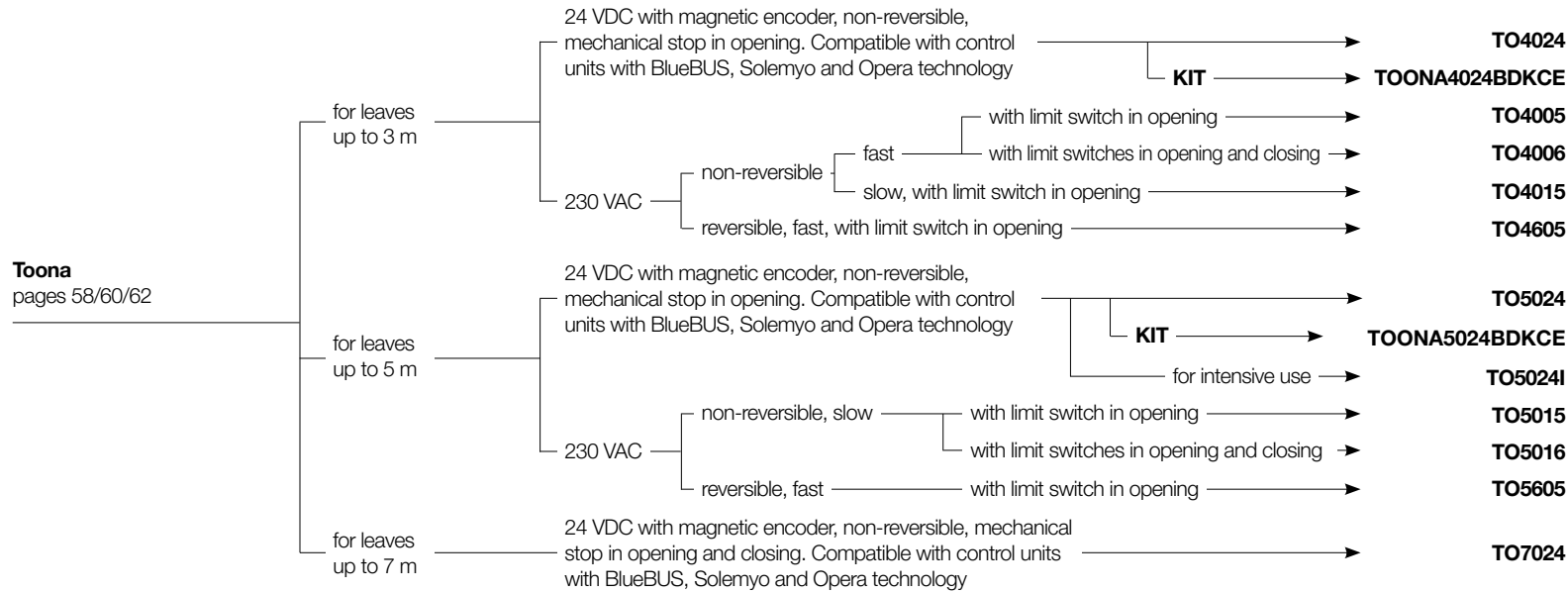

**For integrated installation in post**

For leaves up to 1.8 m and 100 kg. Non-reversible, 24 VDC electromechanical gearmotor. Dedicated control centre with BlueBUS, Solemyo and Opera technology.

**Oltre**  
pages 70

**OLTRE 1824**



**Surface mounted, with articulated arm, recommended for small posts, in a kit with bidirectional technology**

For leaves up to 1.8 m, 24 VDC, non-reversible, with integrated control unit with BlueBUS technology and provision for Solemyo and Opera systems. Mechanical limit switch in closing.

**Walky**  
pages 72

- for 1 leaf → **WALKY1024BDKCE**
- for 2 leaves → **WALKY2024BDKCE**



**Surface mounted, articulated arm, also for large posts and lightweight structures, also available in a kit with bidirectional technology**

For leaves up to 2.4 m, 24 VDC, non-reversible. Control units compatible with Solemyo. With limit switch in opening.

**Hopp**  
pages 74

- integrated control unit, with BlueBUS, Solemyo and Opera technology → **HO7124**
- without integrated control unit → **HO7224**
- KIT** → **HOPPBDKCE**



Nice

# Selection guide

Surface mounted, articulated arm, for large posts, also available in a kit with bidirectional technology

For leaves for leaves up to 3.5 m.

**Hyke**  
pages 76

24 VDC, non-reversible. With limit switches in opening and closing

integrated control unit, with BlueBUS, Solemyo and Opera technology →

**HK7024**

without integrated control unit →

**HK7224**

**KIT** →

**HYKEBDKCE**



For leaves up to 3 m, non-reversible.

**Hyppo**  
pages 78

230 VAC with limit switches in opening and closing →

**HY7005**

24 VDC, with magnetic encoder. Compatible with control units with BlueBUS, Solemyo and Opera technology →

**HY7024**



Underground installation, also available in a kit with bidirectional technology

For leaves up to 2.3 m, 24 VDC, non-reversible, mechanical limit switches in opening and closing.

**S-Fab**  
pages 80

compatible with control units with provision for Solemyo →

**SFAB2024**

**KIT** →

**SFAB2024BDKCE**

with magnetic encoder, compatible with control units with BlueBUS, Solemyo and Opera technology →

**SFAB2124**

**KIT** →

**SFAB2124BDKCE**



## Underground installation

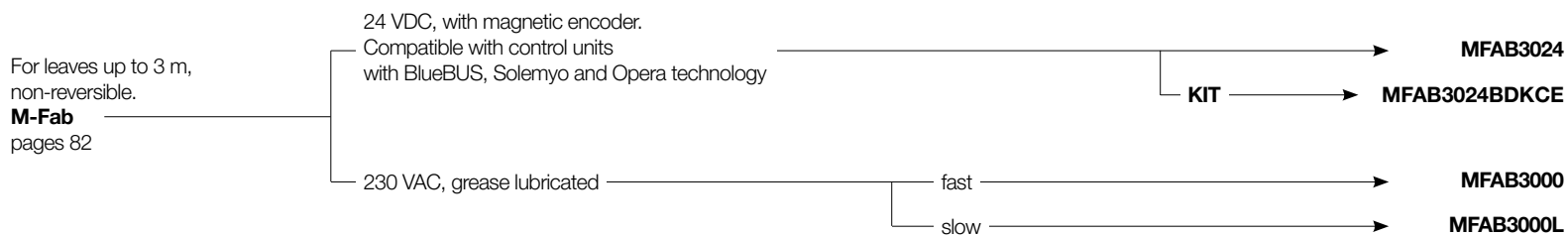

Nice

# Toona 4

For swing gates with leaves up to 3 m.

Ideal for residential applications.



Also available in a KIT

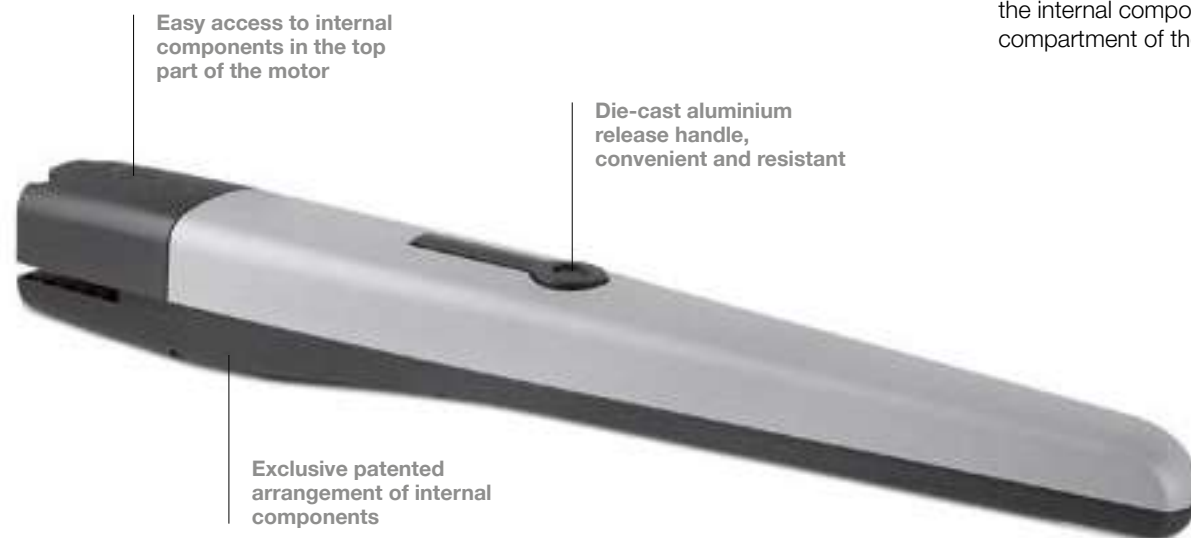

Easy access to internal components in the top part of the motor

Die-cast aluminium release handle, convenient and resistant

Exclusive patented arrangement of internal components

Electromechanical gearmotor, surface mounted. Also available in 24 VDC version, with magnetic encoder.

**Reliable and with a long working life:** thanks to the body with two sturdy polyester painted aluminium shells; more weather-resistant.

Moving internal parts made entirely of steel, light alloys and technopolymers.

**Quiet:** patented arrangement of internal components and bronze screw.

**Handy, capacious connection compartment:** quick and easy access from above to the internal components located in the upper compartment of the motor.

**Easy installation and maintenance:** with built-in condenser.

**Recommended control units:** MC800, Moonclever MC824H for TO4024.

**24 VDC** version with magnetic encoder. **Ideal for intensive use**, compatible with Moonclever MC824H control unit.

BlueBus

BiDi

Programmable via App

24V

Yubii

With Pro-View or Bidi-WiFi & MyNice Pro App.

230V

Solemyo

Opera



Code	Description	Pcs./Pallet
<b>TO4024</b>	Non-reversible, 24 VDC, with magnetic encoder, mechanical stop in opening	20
<b>TO4005</b>	Non-reversible, 230 VAC, fast, with limit switch in opening	20
<b>TO4006</b>	Non-reversible, 230 VAC, fast, with limit switches in opening and closing	20
<b>TO4015</b>	Non-reversible, 230 VAC, slow, with limit switch in opening	20
<b>TO4605</b>	Reversible, 230 VAC, fast, with limit switch in opening	20
<b>TOONA4024BDKCE</b>	Kit for automating swing gates with leaves up to 3 m, 24 VDC, surface mounted, with bidirectional technology	15



#### The TOONA4024BDKCE kit contains:

Code	Description	Quantity
<b>TO4024</b>	Electromechanical gearmotor, non-reversible, surface mounted with mechanical stop in opening	2
<b>MYGO4</b>	4-channel 433.92 MHz transmitter	2
<b>MC824H</b>	Control unit with OXIBD plug-in bidirectional radio receiver included	1
<b>EPMB</b>	Pair of surface mounted photocells with provision for connection via Nice BlueBUS	1
<b>ELDC</b>	Flashing LED light with integrated antenna	1
<b>TS</b>	Sign	1

**N.B.** The contents of the pack may vary: always consult the dealer.

#### COMMON ACCESSORIES

Code	Description	Pcs. Pack
<b>PLA6</b>	Rear bracket, length 250 mm	1
<b>PLA14</b>	Screw-on adjustable rear bracket	2
<b>PLA15</b>	Screw-on adjustable front bracket	2
<b>PLA16</b>	Articulated rear bracket	1
<b>PLA10</b>	Vertical 12 V electric lock	1
<b>PLA11</b>	Horizontal 12 V electric lock	1
<b>PLA13</b>	Mechanical limit switch in opening or closing	4
<b>TS</b>	Sign	1

#### ACCESSORIES FOR 24 V VERSIONS

Code	Description	Pcs. Pack
<b>PSS324</b>	24 V battery with integrated battery charger	1
<b>SYKCE30</b>	Solar power supply kit consisting of SYP30 photovoltaic panel, PSY24 battery box with charging control circuit and SYA1 charger	1

Find out more on page → 88.

#### TECHNICAL SPECIFICATIONS

Code	TO4024	TO4005	TO4006	TO4015	TO4605
<b>ELECTRICAL SPECIFICATIONS</b>					
Power supply (VAC 50 Hz)*	-	230			
Power supply (VDC)	24	-			
Draw (A)	5	1,5		1,3	
Power (W)	120	340		300	
<b>PERFORMANCE DATA</b>					
Speed (m/s)	0,016		0,013		0,016
Force (N)	1800				
Working cycle (cycles/hour)	95**	58		54	50
<b>DIMENSIONAL AND GENERAL DATA</b>					
Protection class (IP)	44				
Operating temperature (°C Min/Max)	-20 ÷ +50				
Dimensions (mm)	820x115x105 h				
Weight (kg)	6				

\* 60 Hz version available on request. \*\* With optimal installation.

#### OPERATING LIMITS

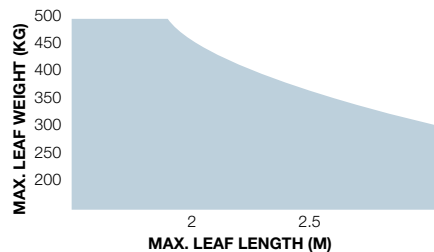

The shape and height of the gate and presence of a strong wind can considerably reduce the values shown in the graph. The 230 VAC models are best for windy areas.

#### DIMENSIONS

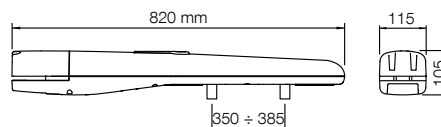

#### COMPATIBILITY WITH CONTROL SYSTEMS AND ACCESSORIES

TO4024 TO4005 TO4006 TO4015 TO4605	Control unit/Receiver
	Integrated*
•	MC824H / OXIBD / OXILR
• • • • •	MC800 / OXIBD / OXILR
	Transmitter
• • • • •	ERA INTI - 2 channels, 433.92 MHz, different colours
• • • • •	ERA ONE / MYGO - 2, 4 or 8 channels, 433.92 MHz
• • • • •	MYGOBD / ERA ONE LR
• • • • •	DOMI
	Photocells
• • • • •	EPS - Slim / EPM - Medium / EPL - Large
• • • • •	EPSB - Slim, BlueBUS / EPMB - Medium, BlueBUS / EPLB - Large, BlueBUS
• • • • •	EPMOR - Medium, reflective
• • • • •	EPMORB - Medium, BlueBUS, reflective
• • • • •	EPMOW - Medium, wireless self-synchronised
• • • • •	F210 - Synchronised, adjustable / FT210 - For sensitive edges
• • • • •	F210B - BlueBUS
	FT210B - For sensitive edges, BlueBUS
	Flashing light
• • • • •	ELAC
•	ELDC
•	WLT - Multifunction LED light

\* Radio receiver not compatible with the O-box functions of the Opera system.

Nice

# Toona 5

**For swing gates with leaves up to 5 m.**

Ideal for residential and industrial applications.



**Also available in a KIT**

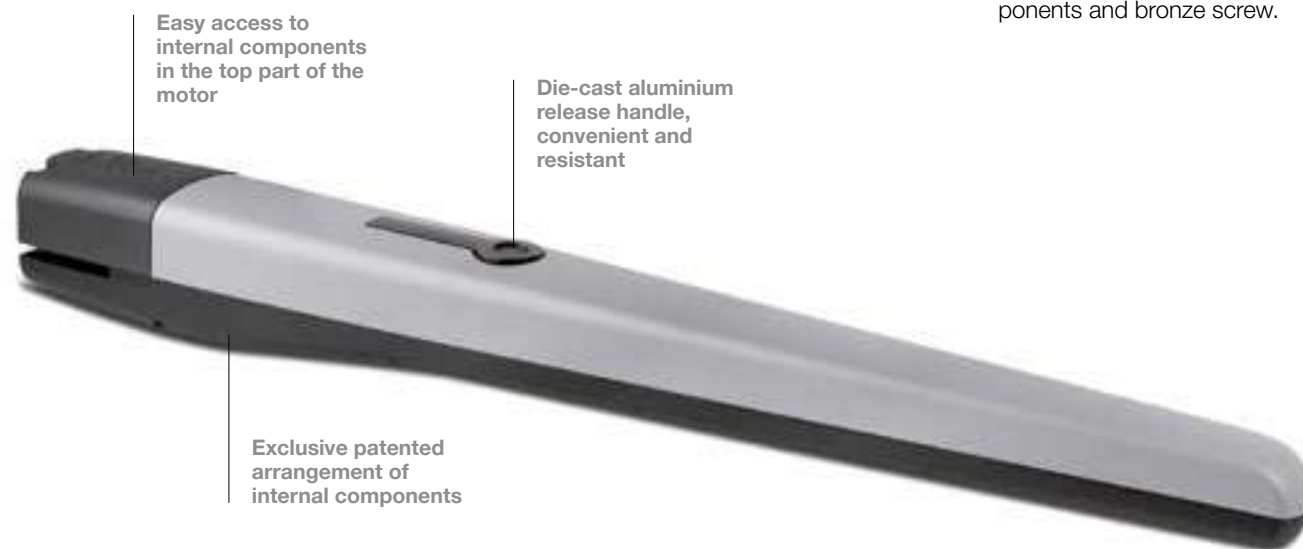

Easy access to internal components in the top part of the motor

Die-cast aluminium release handle, convenient and resistant

Exclusive patented arrangement of internal components

Electromechanical gearmotor, surface mounted. Also available in 24 VDC version, with magnetic encoder.

**Reliable and with a long working life:** thanks to the body with two sturdy polyester painted aluminium shells; more weather-resistant.

Moving internal parts made entirely of steel, light alloys and technopolymers.

**TO5024I** ideal for intensive workloads, the 2200 Nm torque enables it to work in a continuous cycle on large gates.

**Quiet:** patented arrangement of internal components and bronze screw.

**Handy, capacious connection compartment:** quick and easy access from above to the internal components located in the upper compartment of the motor.

**Easy installation and maintenance:** with built-in condenser.

**Recommended control units:** MC800, Moonclever MC824H for TO5024 and TO5024I.

**24 VDC** version with magnetic encoder. **Ideal for intensive use**, compatible with Moonclever MC824H control unit.

BlueBus

BiDi

Programmable via App

24V

Yubii

With Pro-View or Bidi-WiFi & MyNice Pro App.

230V

Solemyo

Opera



Code	Description	Pcs./Pallet
<b>TO5024</b>	Non-reversible, 24 VDC, with magnetic encoder, mechanical stop in opening	20
<b>TO5024I</b>	Non-reversible, 24 VDC, with magnetic encoder, mechanical stop in opening, for intensive use	20
<b>TO5015</b>	Non-reversible, 230 VAC, slow, with limit switch in opening	20
<b>TO5016</b>	Non-reversible, 230 VAC, slow, with limit switch in opening and closing	20
<b>TO5605</b>	Reversible, 230 VAC, fast, with limit switch in opening	20
<b>TOONA5024BDKCE</b>	Kit for automating swing gates with leaves up to 5 m, 24 Vdc, surface mounted, with bidirectional technology	15

#### The TOONA5024BDKCE kit contains:

Code	Description	Pcs. Pack
<b>TO5024</b>	Non-reversible, 24 VDC, with magnetic encoder, mechanical stop in opening	2
<b>MYGO4</b>	4-channel 433.92 MHz transmitter	2
<b>MC824H</b>	Control unit with OXIBD plug-in bidirectional radio receiver included	1
<b>EPMB</b>	Pair of surface mounted photocells with provision for connection via Nice BlueBUS	1
<b>ELDC</b>	Flashing LED light with integrated antenna	1
<b>TS</b>	Sign	1

**N.B.** The contents of the pack may vary: always consult the dealer.

#### COMMON ACCESSORIES

Code	Description	Pcs. Pack
<b>PLA6</b>	Rear bracket, length 250 mm	1
<b>PLA8</b>	Screw-on front bracket	1
<b>PLA16</b>	Articulated rear bracket	1
<b>PLA10</b>	Vertical 12 V electric lock (obligatory for leaves longer than 3 m)	1
<b>PLA11</b>	Horizontal 12 V electric lock (obligatory for leaves longer than 3 m)	1
<b>PLA13</b>	Mechanical limit switch in opening or closing	4
<b>TS</b>	Sign	1

#### ACCESSORIES FOR 24 V VERSIONS

Code	Description	Pcs. Pack
<b>PSS324</b>	24 V battery with integrated battery charger	1
<b>SYKCE30</b>	Solar power supply kit consisting of SYP30 photovoltaic panel, PSY24 battery box with charging control circuit and SYA1 charger	1

Find out more on page → 88.

#### TECHNICAL SPECIFICATIONS

Code	TO5024	TO5024I	TO5015	TO5016	TO5605
------	--------	---------	--------	--------	--------

#### ELECTRICAL SPECIFICATIONS

Power supply (VAC 50 Hz)*	-		230		
Power supply (VDC)	24		-		
Draw (A)	5		1,5		1,3
Power (W)	120		340		300

#### PERFORMANCE DATA

Speed (m/s)	0,016	0,013		0,016
Force (N)	1800	2200	1800	
Working cycle (cycles/hour)	95**	75***		50

#### DIMENSIONAL AND GENERAL DATA

Protection class (IP)	44			
Operating temperature (°C Min/Max)	-20 ÷ +50			
Dimensions (mm)	965x115x105 h			
Weight (kg)	7			

\* 60 Hz version available on request. \*\* With optimal installation. \*\*\* The reduction in number of manoeuvres compared to the TO5024 version is solely related to the slower manoeuvring speed.

#### OPERATING LIMITS

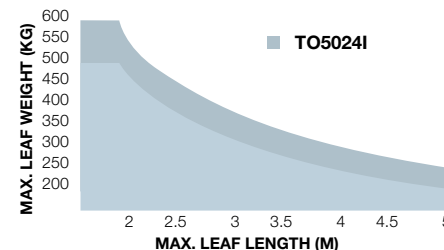

The shape and height of the gate and presence of a strong wind can considerably reduce the values shown in the graph. The 230 VAC models are best for windy areas.

#### DIMENSIONS

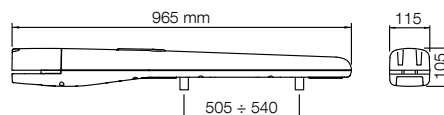

#### COMPATIBILITY WITH CONTROL SYSTEMS AND ACCESSORIES

TO5024	TO5024I	TO5015	TO5016	TO5605	
					<b>Control unit/Receiver</b>
					<b>Integrated*</b>
• •					<b>MC824H / OXIBD / OXILR</b>
	• • •				<b>MC800 / OXIBD / OXILR</b>
					<b>Transmitter</b>
• • • • •					<b>ERA INTI</b> - 2 channels, 433.92 MHz, different colours
• • • • •					<b>ERA ONE / MYGO</b> - 2, 4 or 8 channels, 433.92 MHz
• • • • •					<b>MYGOBD / ERA ONE LR</b>
• • • • •					<b>DOMI</b>
					<b>Photocells</b>
• • • • •					<b>EPS</b> - Slim / <b>EPM</b> - Medium / <b>EPL</b> - Large
• • • • •					<b>EPMB</b> - Slim, BlueBUS / <b>EPMB</b> - Medium, BlueBUS / <b>EPLB</b> - Large, BlueBUS
• • • • •					<b>EPMOR</b> - Medium, reflective
• • • • •					<b>EPMORB</b> - Medium, BlueBUS, reflective
• • • • •					<b>EPMOW</b> - Medium, wireless self-synchronised
• • • • •					<b>F210</b> - Synchronised, adjustable / <b>FT210</b> - For sensitive edges
• • • • •					<b>F210B</b> - BlueBUS
• • • • •					<b>FT210B</b> - For sensitive edges, BlueBUS
					<b>Flashing light</b>
• • •					<b>ELAC</b>
• •					<b>ELDC</b>
• •					<b>WLT</b> - Multifunction LED light

\* Radio receiver not compatible with the O-box functions of the Opera system.

Nice

# Toona 7

**For swing gates with leaves up to 7 m.**

Ideal for intensive-use industrial applications.

Electromechanical gearmotor, surface mounted, powered at 24 VDC with magnetic encoder.

**Reliable and with a long working life:** thanks to the body with two sturdy polyester painted aluminium shells; more weather-resistant.

Moving internal parts made entirely of steel, light alloys and technopolymers.

**Quiet:** patented arrangement of internal components and bronze screw.

**Large, practical connection compartment:** quick and easy access from above to the internal components located in the upper compartment of the motor.

**Moonclever MC824H control unit.**

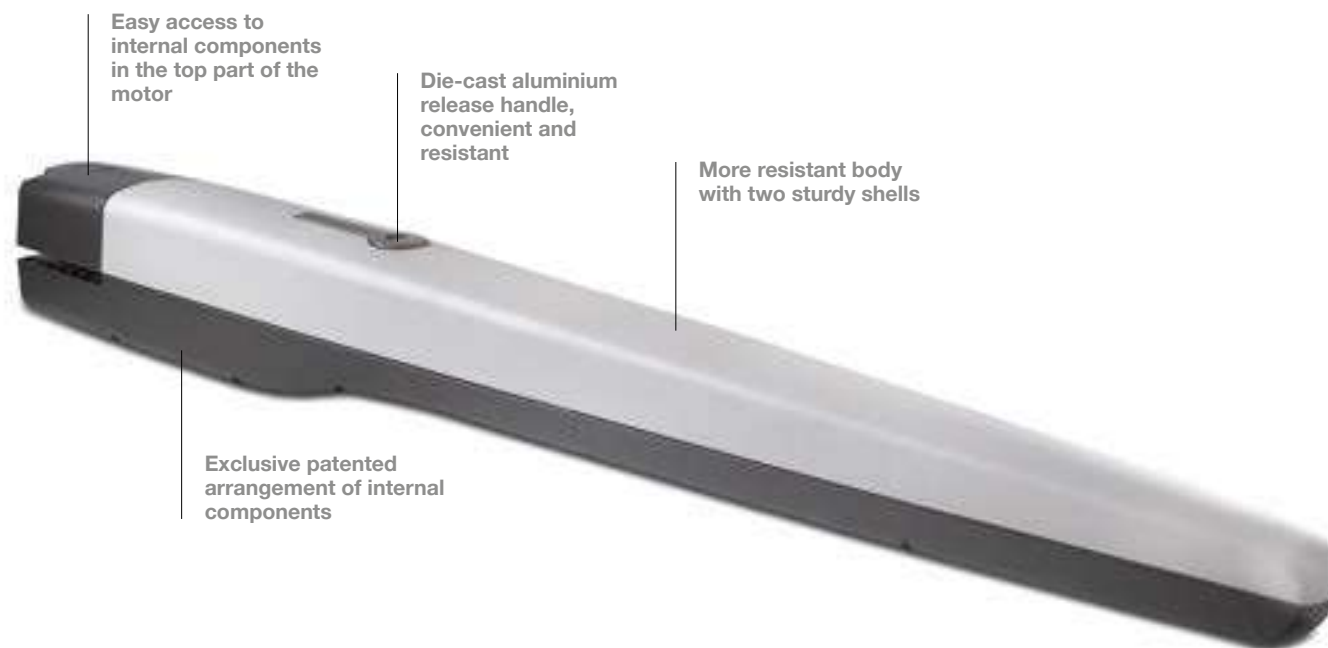

Easy access to internal components in the top part of the motor

Die-cast aluminium release handle, convenient and resistant

More resistant body with two sturdy shells

Exclusive patented arrangement of internal components

BlueBus

BiDi

Programmable via App

24V

Yubii

With Pro-View or Bidi-WiFi & MyNice Pro App.

Solemyo

Opera



Code	Description	Pcs./Pallet
<b>TO7024</b>	Non-reversible, 24 VDC, with magnetic encoder, mechanical stop in opening and closing	20

**COMMON ACCESSORIES**

Code	Description	Pcs. Pack
<b>PSS324</b>	24 V battery with integrated battery charger	1
<b>PLA10</b>	Vertical 12 V electric lock (obligatory for leaves longer than 3 m)	1
<b>PLA11</b>	Horizontal 12 V electric lock (obligatory for leaves longer than 3 m)	1
<b>SYKCE30</b>	Solar power supply kit consisting of SYP30 photovoltaic panel, PSY24 battery box with charging control circuit and SYA1 charger	1
<b>TS</b>	Sign	1

Find out more on page → 88.

**TECHNICAL SPECIFICATIONS**

Code	<b>TO7024</b>
<b>ELECTRICAL SPECIFICATIONS</b>	
Power supply (VDC)	24
Draw (A)	5
Power (W)	120
<b>PERFORMANCE DATA</b>	
Speed (m/s)	0,013
Force (N)	2700
Working cycle (cycles/hour)	41
<b>DIMENSIONAL AND GENERAL DATA</b>	
Protection class (IP)	44
Operating temperature (°C Min/Max)	-20 ÷ +50
Dimensions (mm)	1200x128x150 h
Weight (kg)	15

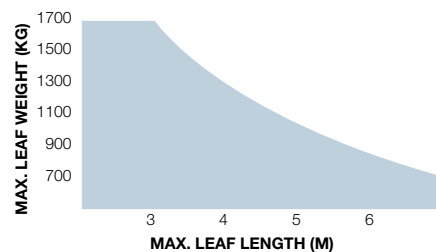
**OPERATING LIMITS**

The shape and height of the gate and presence of a strong wind can considerably reduce the values shown in the graph.

**DIMENSIONS****COMPATIBILITY WITH CONTROL SYSTEMS AND ACCESSORIES**

TO7024

**Control unit/Receiver****Integrated\***

- **MC824H / OXIBD / OXILR**

**Transmitter**

- **ERA INTI** - 2 channels, 433.92 MHz, different colours
- **ERA ONE / MYGO** - 2, 4 or 8 channels, 433.92 MHz
- **MYGOBD / ERA ONE LR**

- **DOMI**

**Photocells**

**EPS** - Slim / **EPM** - Medium / **EPL** - Large

- **EPSB** - Slim, BlueBUS / **EPMB** - Medium, BlueBUS / **EPLB** - Large, BlueBUS

**EPMOR** - Medium, reflective

- **EPMORB** - Medium, BlueBUS, reflective
- **EPMOW** - Medium, wireless self-synchronised
- **F210** - Synchronised, adjustable / **FT210** - For sensitive edges

- **F210B** - BlueBUS

**FT210B** - For sensitive edges, BlueBUS

**Flashing light****ELAC**

- **ELDC**
- **WLT** - Multifunction LED light

\* Radio receiver not compatible with the O-box functions of the Opera system.

Nice

# Wingo 4

For swing gates with leaves up to 2 m.



Available in a KIT



Electromechanical gearmotor, surface mounted.  
Also available in a 24 Vdc version.

**Reliable and quiet:** patented arrangement of internal components and fewer moving parts.

**Easy to install:** electrical connections from above, with gearmotor mounted.

**Built-in condenser for WG4000.**

**Easy release** with personalised Nice key and standard lock.

**Pre-mounted mechanical limit switches** in opening.

**Recommended control units:** MC800, for WG4000 and Moonclever MC424L for WG4024.

BlueBus

24V

230V

BiDi

Yubii

Solemyo

Opera

Programmable via App

With Pro-View or Bidi-WiFi & MyNice Pro App.



Code	Description	Pcs./Pallet
<b>WINGO4BDKCE</b>	Kit for automating swing gates with leaves up to 2 m, surface mounted, with bidirectional technology	15
<b>WINGO4024BDKCE</b>	Kit for automating swing gates with leaves up to 2 m, 24 VDC, surface mounted, with bidirectional technology	15

**The WINGO4BDKCE kit contains:**

Code	Description	Quantity
<b>WG4000</b>	Electromechanical gearmotor, surface mounted with Nice key release and mechanical limit switch in opening	2
<b>INTI2</b>	Transmitter, 433.92 MHz, 2 channels	2
<b>MC800</b>	Control unit with OXIBD bidirectional radio receiver included	1
<b>EPM</b>	Pair of surface mounted photocells	1
<b>ELAC</b>	Flashing LED light with integrated antenna	1
<b>TS</b>	Sign	1

**The WINGO4024BDKCE kit contains:**

Code	Description	Quantity
<b>WG4024</b>	Electromechanical gearmotor, surface mounted with Nice key release and mechanical limit switch in opening	2
<b>INTI2</b>	Transmitter, 433.92 MHz, 2 channels	2
<b>MC424L</b>	Control unit with integrated radio receiver	1
<b>EPM</b>	Pair of surface mounted photocells	1
<b>ELDC</b>	Flashing LED light with integrated antenna	1
<b>TS</b>	Sign	1

**N.B.** The contents of the pack may vary: always consult the dealer.

**COMMON ACCESSORIES**

Code	Description	Pcs. Pack
<b>PLA14</b>	Screw-on adjustable rear bracket	2
<b>PLA15</b>	Screw-on adjustable front bracket	2
<b>PLA10</b>	Vertical 12 V electric lock (obligatory for leaves longer than 3 m)	1
<b>PLA11</b>	Horizontal 12 V electric lock (obligatory for leaves longer than 3 m)	1

**ACCESSORIES FOR 24 V VERSIONS**

Code	Description	Pcs. Pack
<b>PSS124</b>	24 V battery with integrated battery charger	1
<b>SYKCE30</b>	Solar power supply kit consisting of SYP30 photovoltaic panel, PSY24 battery box with charging control circuit and SYA1 charger	1

Find out more on page → 88.

**TECHNICAL SPECIFICATIONS**

Code	WG4000	WG4024
<b>ELECTRICAL SPECIFICATIONS</b>		
Power supply (VAC 50 Hz)*	230	-
Alimentazione (Vdc)	-	24
Draw (A)	1,5	3,5
Power (W)	200	85
<b>PERFORMANCE DATA</b>		
Speed (m/s)	0,016	0,018
Force (N)		1500
Working cycle (cycles/hour)		30
<b>DIMENSIONAL AND GENERAL DATA</b>		
Protection class (IP)		44
Operating temperature (°C Min/Max)		-20 ÷ +50
Dimensions (mm)		770x98x95 h
Weight (kg)		6

\* 60 Hz version available on request.

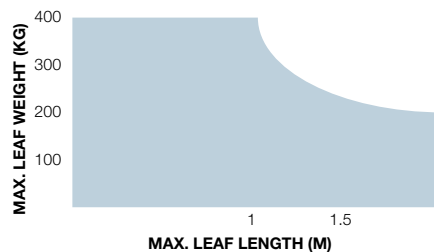
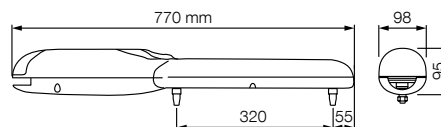
**OPERATING LIMITS****DIMENSIONS****COMPATIBILITY WITH CONTROL SYSTEMS AND ACCESSORIES**

WG4000  
WG4024

<b>Control unit/Receiver</b>
<b>Integrated*</b>
• <b>MC800* / OXIBD / OXILR</b>
• <b>MC424L* / OXIBD / OXILR</b>
<b>Transmitter</b>
• <b>ERA INTI</b> - 2 channels, 433.92 MHz, different colours
• <b>ERA ONE / MYGO</b> - 2, 4 or 8 channels, 433.92 MHz
• <b>MYGOBD / ERA ONE LR</b>
• <b>DOMi</b>
<b>Photocells</b>
• <b>EPS</b> - Slim / <b>EPM</b> - Medium / <b>EPL</b> - Large
• <b>EPSB</b> - Slim, BlueBUS / <b>EPMB</b> - Medium, BlueBUS / <b>EPLB</b> - Large, BlueBUS
• <b>EPMOR</b> - Medium, reflective
• <b>EPMORB</b> - Medium, BlueBUS, reflective
• <b>EPMOW</b> - Medium, wireless self-synchronised
• <b>F210</b> - Synchronised, adjustable / <b>FT210</b> - For sensitive edges
• <b>F210B</b> - BlueBUS
<b>FT210B</b> - For sensitive edges, BlueBUS
<b>Flashing light</b>
• <b>ELAC</b>
• <b>ELDC</b>
• <b>WLT</b> - Multifunction LED light

\* Radio receiver not compatible with the O-box functions of the Opera system.

Nice

# Wingo 5

For swing gates with leaves up to 3.5 m.



Available in a KIT

Electromechanical gearmotor, surface mounted. Also available in a 24 Vdc version.

**Reliable and quiet:** patented arrangement of internal components and fewer moving parts.

**Easy to install:** electrical connections from above, with gearmotor mounted.

**Easy release** with personalised Nice key and standard lock.

**Pre-mounted mechanical limit switches** in opening.

**Recommended control units:** MC800, for WG5000 and Moonclever MC424L for WG5024.



BlueBus

BiDi

230V

Yubii

Opera

Programmable via App

With Pro-View or Bidi-WiFi & MyNice Pro App.



Code	Description	Pcs./Pallet
<b>WINGO5BDKCE</b>	Kit for automating swing gates with leaves up to 3.5 m, surface mounted, with bidirectional technology	15
<b>WINGO5024BDKCE</b>	Kit for automating swing gates with leaves up to 3.5 m, 24 VDC, surface mounted, with bidirectional technology	15

**The WINGO5BDKCE kit contains:**

Code	Description	Quantity
<b>WG5000</b>	Electromechanical gearmotor, surface mounted with Nice key release and mechanical limit switch in opening	2
<b>INTI2</b>	Transmitter, 433.92 MHz, 2 channels	2
<b>MC800</b>	Control unit with OXIBD bidirectional radio receiver included	1
<b>EPM</b>	Pair of surface mounted photocells	1
<b>ELAC</b>	Flashing LED light with integrated antenna.	1
<b>TS</b>	Sign	1

**The WINGO5024BDKCE kit contains:**

Code	Description	Quantity
<b>WG5024</b>	Electromechanical gearmotor, surface mounted with Nice key release and mechanical limit switch in opening	2
<b>INTI2</b>	Transmitter, 433.92 MHz, 2 channels	2
<b>MC424L</b>	Control unit with integrated radio receiver	1
<b>EPM</b>	Pair of surface mounted photocells	1
<b>ELDC</b>	Flashing LED light with integrated antenna	1
<b>TS</b>	Sign	1

N.B. The contents of the pack may vary: always consult the dealer.

**COMMON ACCESSORIES**

Code	Description	Pcs. Pack
<b>PLA6</b>	Rear bracket, length 250 mm	1
<b>PLA8</b>	Screw-on front bracket	1
<b>PLA10</b>	Vertical 12 V electric lock (obligatory for leaves longer than 3 m)	1
<b>PLA11</b>	Horizontal 12 V electric lock (obligatory for leaves longer than 3 m)	1

**ACCESSORIES FOR 24 V VERSIONS**

Code	Description	Pcs. Pack
<b>PSS124</b>	24 V battery with integrated battery charger	1
<b>SYKCE30</b>	Solar power supply kit consisting of SYP30 photovoltaic panel, PSY24 battery box with charging control circuit and SYA1 charger	1

Find out more on page → 88.

**TECHNICAL SPECIFICATIONS**

Code	WG5000	WG5024
<b>ELECTRICAL SPECIFICATIONS</b>		
Power supply (VAC 50 Hz)*	230	-
Power supply (VDC)	-	24
Draw (A)	1,5	3,5
Power (W)	200	85
<b>PERFORMANCE DATA</b>		
Speed (m/s)	0,013	0,016
Force (N)	1700	1500
Working cycle (cycles/hour)	30	
<b>DIMENSIONAL AND GENERAL DATA</b>		
Protection class (IP)	44	
Operating temperature (°C Min/Max)	-20 ÷ +50	
Dimensions (mm)	920x98x95 h	
Weight (kg)	6	

\* 60 Hz version available on request.

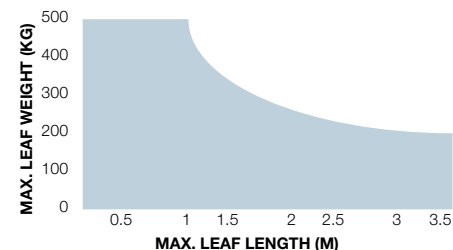
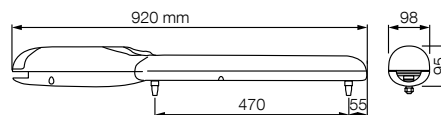
**OPERATING LIMITS****DIMENSIONS****COMPATIBILITY WITH CONTROL SYSTEMS AND ACCESSORIES**

WG5000  
WG5024

<b>Control unit/Receiver</b>
<b>Integrated*</b>
• <b>MC800* / OXIBD / OXILR</b>
• <b>MC424L* / OXIBD / OXILR</b>
<b>Transmitter</b>
• <b>ERA INTI</b> - 2 channels, 433.92 MHz, different colours
• <b>ERA ONE / MYGO</b> - 2, 4 or 8 channels, 433.92 MHz
• <b>MYGOBD / ERA ONE LR</b>
• <b>DOMi</b>
<b>Photocells</b>
• <b>EPS</b> - Slim / <b>EPM</b> - Medium / <b>EPL</b> - Large
• <b>EPSB</b> - Slim, BlueBUS / <b>EPMB</b> - Medium, BlueBUS / <b>EPLB</b> - Large, BlueBUS
• <b>EPMOR</b> - Medium, reflective
• <b>EPMORB</b> - Medium, BlueBUS, reflective
• <b>EPMOW</b> - Medium, wireless self-synchronised
• <b>F210</b> - Synchronised, adjustable / <b>FT210</b> - For sensitive edges
• <b>F210B</b> - BlueBUS
<b>FT210B</b> - For sensitive edges, BlueBUS
<b>Flashing light</b>
• <b>ELAC</b>
• <b>ELDC</b>
• <b>WLT</b> - Multifunction LED light

\* Radio receiver not compatible with the O-box functions of the Opera system.

Nice

# Too

## For swing gates with leaves up to 4.5 m.



Available in a KIT

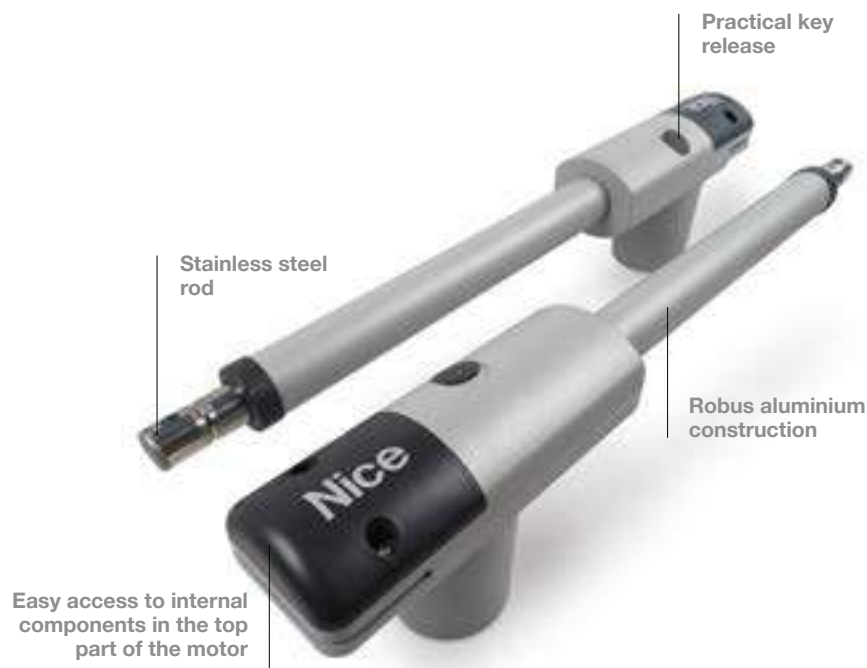

Telescopic electromechanical gearmotor, surface mounted. Ideal for residential use.

**Versatile**, thanks to its rod shape available in both versions with travel up to 400 mm and 500 mm, the motor adapts to any kind of swing gate.

**Sleek design**, ideal for modern homes.

Reliable and long-lasting thanks to its robust epoxy powder-coated aluminium construction; stainless steel rod.

**Handy connection compartment:** easy access to internal components in the top part of the motor.

**Easy to install**, no welding with the brackets provided and easily adjustable rear fastening.

**Practical unlocking:** with Nice-branded key on top of the motor.

**Recommended control unit:** MC800, for TOO3000 and TOO4500, Moonclever MC424L for TOO3024 and TOO4524.

Code	Description	Pcs./Pallet
<b>TOO3000KCE</b>	Kit for automating swing gates with leaves up to 3 m and 300 kg, 230 VAC, surface mounted.	18
<b>TOO4500KCE</b>	Kit for automating swing gates with leaves up to 4.5 m and 250 kg, 230 VAC, surface mounted.	18
<b>TOO3024KCE</b>	Kit for automating swing gates with leaves up to 3 m and 300 kg, 24 VDC, surface mounted. Compatible with Solemyo	18
<b>TOO4524KCE</b>	Kit for automating swing gates with leaves up to 4.5 m and 250 kg, 24 VDC, surface mounted. Compatible with Solemyo	18

**N.B.** Pack contents may vary: always consult the dealer.

24V

BiDi

Programmable via App

230V

Solemyo

With Pro-View or Bidi-WiFi & MyNice Pro App.

Opera



**The TOO3000KCE kit contains:**

Code	Description	Quantity
<b>TOO3000</b>	Telescopic motor, 230 VAC, for leaves up to 3 metres and 300 kg	2
<b>INTI2</b>	Transmitter, 433.92 MHz, 2 channels	2
<b>MC800</b>	Control unit with OXIBD bidirectional radio receiver included	1
<b>EPM</b>	Pair of surface mounted photocells	1
<b>ELAC</b>	Flashing LED light with integrated antenna	1
<b>TS</b>	Safety sign	1

**The TOO4500KCE kit contains:**

Code	Description	Quantity
<b>TOO4500</b>	Telescopic motor, 230 VAC, for leaves up to 4.5 metres and 250 kg	2
<b>INTI2</b>	Transmitter, 433.92 MHz, 2 channels	2
<b>MC800</b>	Control unit with OXIBD bidirectional radio receiver included	1
<b>EPM</b>	Pair of surface mounted photocells	1
<b>ELAC</b>	Flashing LED light with integrated antenna	1
<b>TS</b>	Safety sign	1

**The TOO3024KCE kit contains:**

Code	Description	Quantity
<b>TOO3024</b>	Telescopic motor, 24 VDC, for leaves up to 3 metres and 300 kg.	2
<b>INTI2</b>	Transmitter, 433.92 MHz, 2 channels	2
<b>MC424L</b>	Control unit with integrated radio receiver	1
<b>EPM</b>	Pair of surface mounted photocells	1
<b>ELDC</b>	Flashing LED light with integrated antenna	1
<b>TS</b>	Safety sign	1

**The TOO4524KCE kit contains:**

Code	Description	Quantity
<b>TOO4524</b>	Telescopic motor, 24 VDC, for leaves up to 4.5 metres and 250 kg.	2
<b>INTI2</b>	Transmitter, 433.92 MHz, 2 channels	2
<b>MC424L</b>	Control unit with integrated radio receiver	1
<b>EPM</b>	Pair of surface mounted photocells	1
<b>ELDC</b>	Flashing LED light with integrated antenna	1
<b>TS</b>	Safety sign	1

N.B. Pack contents may vary: always consult the dealer.

**COMMON ACCESSORIES**

Code	Description	Pcs Pack
<b>PLA10</b>	Vertical 12 V electric lock (obligatory for leaves longer than 3 m)	1
<b>PLA11</b>	Horizontal 12 V electric lock (obligatory for leaves longer than 3 m)	1

**ACCESSORIES FOR 24 V VERSIONS**

Code	Description	Pcs. Pack
<b>PSS124</b>	24 V battery with integrated battery charger	1
<b>SYKCE30</b>	Solar power supply kit consisting of SYP30 photovoltaic panel, PSY24 battery box with charging control circuit and SYA1 charger	1

Code	TOO3000	TOO4500
<b>ELECTRICAL SPECIFICATIONS</b>		
Power supply (VAC 50/60 Hz)	230	230
Draw (A)	1,1	1,1
Power (W)	250	250
<b>PERFORMANCE DATA</b>		
Speed (m/s)	0,016	0,016
Force (N)	300	300
Working cycle (cycles/hour)	24	24
<b>DIMENSIONAL AND GENERAL DATA</b>		
Protection class (IP)	54	
Operating temperature (°C Min/Max)	-20 ÷ +50	
Dimensions (mm)	700x100x177 h	800x100x177 h
Weight (kg)	5,5	6

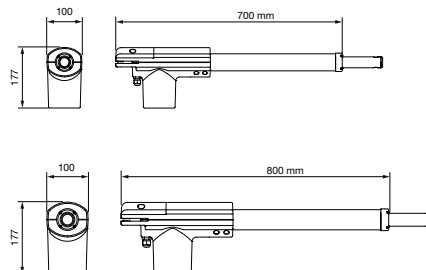
**DIMENSIONS****COMPATIBILITY WITH CONTROL SYSTEMS AND ACCESSORIES**

TOO3000  
TOO4500

**Control unit/Receiver****Integrated\***

- • OXIBD / OXILR

**Transmitter**

- • ERA INTI - 2 channels, 433.92 MHz, different colours
- • ERA ONE / MYGO - 2, 4 or 8 channels, 433.92 MHz
- • MYGOBD / ERA ONE LR
- • DOMI

**Photocells**

- • EPS - Slim / EPM - Medium / EPL - Large
- • EPSB - Slim, BlueBUS / EPMB - Medium, BlueBUS / EPLB - Large, BlueBUS
- • EPMOR - Medium, reflective
- • EPMORB - Medium, BlueBUS, reflective
- • EPMOW - Medium, wireless self-synchronised
- • FT210 - Synchronised, adjustable / FT210 - For sensitive edges
- • FT210B - BlueBUS

FT210B - For sensitive edges, BlueBUS

**Flashing light**

- • ELAC

**ELDC**

WLT - Multifunction LED light

\* Radio receiver not compatible with the O-box functions of the Opera system.

Nice

# Oltre 1824

For swing gates with leaves up to 1.8 m and 100 kg.

Concealed motor.



The position of the gearmotor protects it from rain and infiltrations

Practical bracket for precise motor positioning

Electromechanical gearmotor, non-reversible, 24 VDC.

**Minimum visual impact:** the motor is small enough to be easily installed inside the profiles of the gate leaf or in very slim posts (with a minimum diameter of 55 mm).

**Easy to install:** the bottom-up installation simplifies fixing of the motor inside the post.

**Resistant:** die-cast aluminium structure, IP67, resists the most severe weather conditions.

**Fast and reliable:** complete opening (90°) of the leaf in about 10 seconds. Oltre has been tested for use at 60 cycles/hour, making it suitable for all contexts with intensive use.

**Safe:** easy-to-use external manual release; manual opening is always possible, without having to take the gate apart.

**Dedicated Moonclever MC824L control unit.**

BlueBus

BiDi

Programmable via App

24V

Yubii

With Pro-View or Bidi-WiFi & MyNice Pro App.

Solemyo

Opera



Code	Description	Pcs./Pallet
<b>OLTRE1824</b>	24 VDC non-reversible, for integrated installation in the post or leaf profile, with release lever	20
<b>OLTRE1824KCE</b>	Kit for automating swing gates with one leaf up to 1.8 m, 24 VDC, for integrated installation in the post, with bidirectional technology	



#### The OLTRE1824KCE kit contains:

Code	Description	Quantity
<b>OLTRE1824</b>	24 VDC non-reversible, for integrated installation in the post or leaf profile, with release lever, with leaves up to 1.8 m and 100 kg	2
<b>INTI2</b>	Transmitter, 433.92 MHz, 2 channels	1
<b>MC824L</b>	Control unit with OXIBD plug-in bidirectional radio receiver included, without encoder	1
<b>EPMB</b>	Pair of surface mounted photocells with provision for connection via Nice BlueBUS	1
<b>ELDC</b>	Flashing LED light with integrated antenna	1
<b>TS</b>	Safety sign	1

**N.B.** Pack contents may vary: always consult the dealer.

#### COMMON ACCESSORIES

Code	Description	Pcs. Pack
<b>PSS324</b>	24 V battery with integrated battery charger	1
<b>PLA10</b>	Vertical 12 V electric lock	1
<b>PLA11</b>	Horizontal 12 V electric lock	1
<b>SYKCE30</b>	Solar power supply kit consisting of SYP30 photovoltaic panel, PSY24 battery box with charging control circuit and SYA1 charger	1
<b>TS</b>	Sign	1

Find out more on page → 88.

#### TECHNICAL SPECIFICATIONS

Code	OLTRE1824
<b>ELECTRICAL SPECIFICATIONS</b>	
Power supply (VDC)	24
Draw (A)	1
Power (W)	25
<b>PERFORMANCE DATA</b>	
Speed (m/s)	1,5
Torque (Nm)	150
Working cycle (cycles/hour)	60
<b>DIMENSIONAL AND GENERAL DATA</b>	
Protection class (IP)	67
Operating temperature (°C Min/Max)	-20 ÷ +50
Dimensions (mm)	305x145x346 h
Weight (kg)	5,5

#### DIMENSIONS

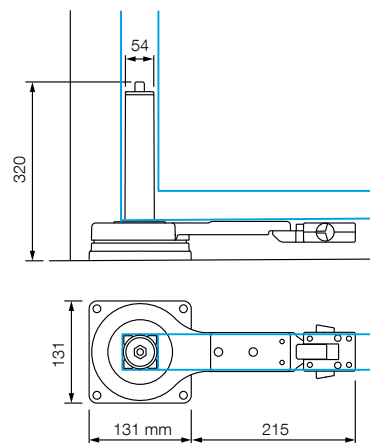

#### COMPATIBILITY WITH CONTROL SYSTEMS AND ACCESSORIES

OLTRE1824

##### Control unit/Receiver

###### Integrated\*

- **MC824L / OXIBD / OXILR**

###### Transmitter

- **ERA INTI** - 2 channels, 433.92 MHz, different colours
- **ERA ONE / MYGO** - 2, 4 or 8 channels, 433.92 MHz
- **MYGOBD / ERA ONE LR**

- **DOMI**

###### Photocells

- **EPS** - Slim / **EPM** - Medium / **EPL** - Large
- **EPSB** - Slim, BlueBUS / **EPMB** - Medium, BlueBUS / **EPLB** - Large, BlueBUS
- **EPMOR** - Medium, reflective
- **EPMORB** - Medium, BlueBUS, reflective
- **EPMOW** - Medium, wireless self-synchronised
- **F210** - Synchronised, adjustable / **FT210** - For sensitive edges
- **F210B** - BlueBUS
- **FT210B** - For sensitive edges, BlueBUS

###### Flashing light

###### ELAC

- **ELDC**
- **WLT** - Multifunction LED light

\* Radio receiver not compatible with the O-box functions of the Opera system.

Nice

# Walky

**For swing gates with one leaf up to 1.8 m.**

Ideal for wood or PVC gates.



Available in a KIT



BlueBus

BiDi

Programmable via  
App

24V

Yubii

With Pro-View or  
BiDi-WiFi Ext  
& MyNice  
Pro App.

Solemyo

Opera



Electromechanical gearmotor, non-reversible, 24 VDC, with articulated arm.

**Ultra compact:** ideal for pedestrian gates, recommended for small posts (8 cm wide).

**Safe:** thanks to the non-reversible motor and anti-shear arm with integrated mechanical limit switch in closing (with full-arm installation).

**Practical:** the articulated arm makes installation possible in particular conditions, such as the presence of walls or obstacles near the post.

**Fast:** no waiting in front of the gate, just 7 seconds to open or close (under optimal installation conditions, with reduced arm and 90° opening).

**Convenient:** LED flashing light for integrated installation, acting as a courtesy light (WLT, optional); quick motor release to operate the gate manually.

**Integrated control unit.**

**No blackouts:** operation in event of power failure with the optional batteries (PS424) housed in the motor.

Code	Description	Pcs./Pallet
<b>WALKY1024BDKCE</b>	Kit for automating swing gates with one leaf up to 1.8 m, 24 VDC, with articulated arm, surface mounted, with bidirectional technology	18
<b>WALKY2024BDKCE</b>	Kit for automating swing gates with two leaves up to 1.8 m, 24 VDC, with articulated arm, surface mounted, with bidirectional technology	18

**The WALKY1024BDKCE kit contains:**

Code	Description	Quantity
<b>WL1024C</b>	Electromechanical gearmotor, surface mounted, with integrated control unit and OXIBD plug-in bidirectional radio receiver included	1
<b>MYGO4</b>	4-channel 433.92 MHz transmitter	2
<b>TS</b>	Sign	1

**The WALKY2024BDKCE kit contains:**

Code	Description	Quantity
<b>WL1024C</b>	Electromechanical gearmotor, surface mounted, with integrated control unit and OXIBD plug-in bidirectional radio receiver included	1
<b>WL1024</b>	Electromechanical gearmotor, surface mounted, without control unit	1
<b>MYGO4</b>	4-channel 433.92 MHz transmitter	2
<b>EPMB</b>	Pair of surface mounted photocells with provision for connection via Nice BlueBUS	1
<b>WLT</b>	Multifunction LED signal light	1
<b>TS</b>	Sign	1

N.B. The contents of the pack may vary: always consult the dealer.

**COMMON ACCESSORIES**

Code	Description	Pcs. Pack
<b>WLA1</b>	Spare control unit for WL1024C	1
<b>PS424</b>	Buffer battery	1
<b>PLA10</b>	Vertical 12 V electric lock	1
<b>PLA11</b>	Horizontal 12 V electric lock	1
<b>WLT</b>	Multifunction LED signal light	1
<b>SYKCE30</b>	Solar power supply kit consisting of SYP30 photovoltaic panel, PSY24 battery box with charging control circuit and SYA1 charger	1

Find out more on page → 88.

**TECHNICAL SPECIFICATIONS**

Code	WL1024C	WL1024
<b>ELECTRICAL SPECIFICATIONS</b>		
Power supply (VAC 50/60 Hz)	230	-
Power supply (Vdc)	-	24
Draw (A)	0,8	2
Power (W)	120	30
<b>PERFORMANCE DATA</b>		
Speed (rpm)	1,5 - 2,2	
Torque (Nm)	120	
Working cycle (cycles/hour)	50	
<b>DIMENSIONAL AND GENERAL DATA</b>		
Protection class (IP)	44	
Operating temperature (°C Min/Max)	-20 ÷ +50	
Dimensions (mm)	90x125x385 h	
Weight (kg)	4,8	4,3

**OPERATING LIMITS**

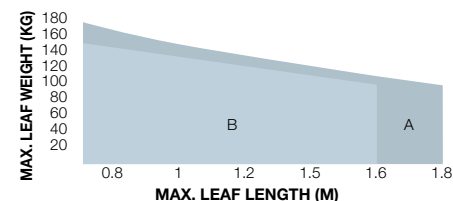
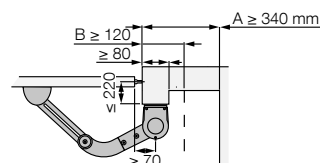

A Full arm - B Reduced arm  
The shape and height of the gate and presence of a strong wind can considerably reduce the values shown in the graph.

**DIMENSIONS**

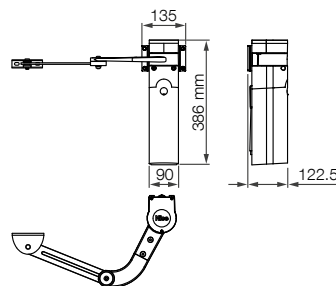

**COMPATIBILITY WITH CONTROL SYSTEMS AND ACCESSORIES**

WL1024C  
WL1024

**Control unit/Receiver**

**Integrated\***

- • OXIBD / OXILR

**Transmitter**

- • ERA INTI - 2 channels, 433.92 MHz, different colours
- • ERA ONE / MYGO - 2, 4 or 8 channels, 433.92 MHz
- • MYGOBD / ERA ONE LR
- • DOMI

**Photocells**

- • EPS - Slim / EPM - Medium / EPL - Large
- • EPSB - Slim, BlueBUS / EPMB - Medium, BlueBUS / EPLB - Large, BlueBUS
- • EPMOR - Medium, reflective
- • EPMORB - Medium, BlueBUS, reflective
- • EPMOW - Medium, wireless self-synchronised
- • F210 - Synchronised, adjustable / FT210 - For sensitive edges
- • F210B - BlueBUS

FT210B - For sensitive edges, BlueBUS

**Flashing light**

**ELAC**

- • ELDC
- • WLT - Multifunction LED light

\* Radio receiver not compatible with the O-box functions of the Opera system.

Nice

# Hopp

**For swing gates with leaves up to 2.4 m including with large posts and lightweight structures.**

Ideal for intensive use.



Also available in a KIT

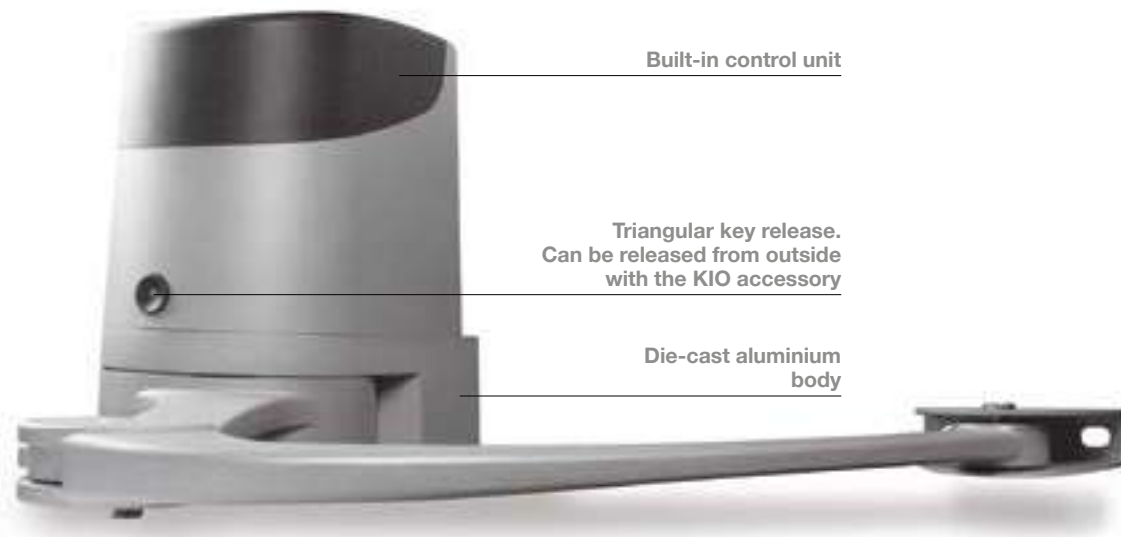

Built-in control unit

Triangular key release.  
Can be released from outside  
with the KIO accessory

Die-cast aluminium  
body

Electromechanical gearmotor, non-reversible, 24 VDC, surface mounted, with articulated arm.

**Two versions** non-reversible, 24 VDC, mechanical stops with millimetric regulation in opening and closing: with integrated control unit (HO7124) and without control unit (HO7224).

**Powerful** thanks to the 250 Nm torque.

**Resistant and compact:** 180 mm wide, ideal for any post. Compact shockproof body with aluminium base.

**Sturdy anti-shear aluminium arm.**

**Easy to install:** thanks to the new fixing bracket with quick coupling for the motor. No welding.

**Sophisticated electronics with integrated control unit,** just 3 keys to manage programming operations.

**Energy saving and no blackouts:** standby consumption < 0.25W, compatible with Solemyo kit. Operation even with no power thanks to the optional batteries (PSS124).

**Everything under control:** thanks to provision for the Opera BUS T4 system, the Pro-View unit can be used to expand the automation programming, control and diagnostics possibilities, both locally and remotely.

BlueBus

BiDi

Programmable via  
App

24V

Yubii

With Pro-View or  
Bidi-WiFi & MyNice  
Pro App.

Solemyo

Opera



Code	Description	Pcs./Pallet
<b>HO7124</b>	Non-reversible, 24 VDC, complete with articulated arm, with integrated control unit	16
<b>HO7224</b>	Non-reversible, 24 VDC, complete with articulated arm, without control unit	16
<b>HOPPBKCE</b>	Kit for automating swing gates with leaves up to 2.4 m, 24 VDC, surface mounted, with bidirectional technology	16



#### The HOPPBKCE kit contains:

Code	Description	Quantity
<b>HO7124</b>	Electromechanical gearmotor, surface mounted, with control unit and OXIBD plug-in bidirectional radio receiver included	1
<b>HO7224</b>	Electromechanical gearmotor, surface mounted, without control unit	1
<b>MYGO4</b>	4-channel 433.92 MHz transmitter	2
<b>EPMB</b>	Pair of surface mounted photocells with provision for connection via Nice BlueBUS	1
<b>ELDC</b>	Flashing LED light with integrated antenna	1
<b>TS</b>	Sign	1

**N.B.** The contents of the pack may vary: always consult the dealer.

#### COMMON ACCESSORIES

Code	Description	Pcs. Pack
<b>SPPOA3R30</b>	Spare control unit for HO7124	1
<b>PSS124</b>	24 V battery with integrated battery charger	1
<b>PLA10</b>	Vertical 12 V electric lock	1
<b>PLA11</b>	Horizontal 12 V electric lock	1
<b>KIO</b>	Key switch for low-voltage contacts, with release mechanism for metal cable	1
<b>KA1</b>	Kit with 6 m metal cable for KIO	1
<b>SYKCE30</b>	Solar power supply kit consisting of SYP30 photovoltaic panel, PSY24 battery box with charging control circuit and SYA1 charger	1
<b>TS</b>	Sign	1

Find out more on page → 88.

#### TECHNICAL SPECIFICATIONS

Code	HO7124	HO7224
<b>ELECTRICAL SPECIFICATIONS</b>		
Power supply (VAC 50/60 Hz)	230	-
Power supply (VDC)	-	24
Draw (A)	1,3	4
Power (W)	280	100
Standby power (W)	< 0.25	

#### PERFORMANCE DATA

Speed (rpm)	1,68
Torque (Nm)	250
Working cycle (cycles/hour)	35

#### DIMENSIONAL AND GENERAL DATA

Protection class (IP)	54
Operating temperature (°C Min/Max)	-20 ÷ +50
Dimensions (mm)	252x180x290 h
Weight (kg)	9

#### OPERATING LIMITS

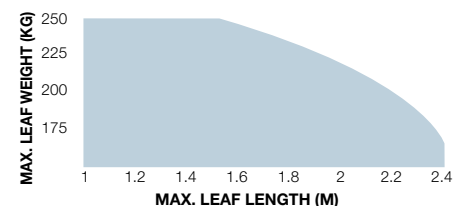
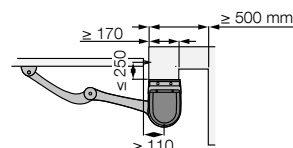

The shape and height of the gate and presence of a strong wind can considerably reduce the values shown in the graph.

#### DIMENSIONS

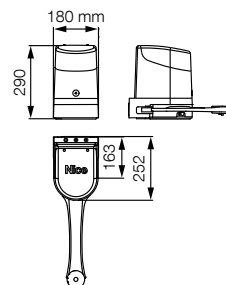

#### COMPATIBILITY WITH CONTROL SYSTEMS AND ACCESSORIES

HO7124

##### Control unit/Receiver

Integrated\*

- OXIBD / OXILR

##### Transmitter

- ERA INTI - 2 channels, 433.92 MHz, different colours
- ERA ONE / MYGO - 2, 4 or 8 channels, 433.92 MHz
- MYGOBD / ERA ONE LR

- DOMI

##### Photocells

- EPS - Slim / EPM - Medium / EPL - Large
- EPSB - Slim, BlueBUS / EPMB - Medium, BlueBUS / EPLB - Large, BlueBUS

EPMOR - Medium, reflective

- EPMORB - Medium, BlueBUS, reflective

- EPMOW - Medium, wireless self-synchronised

FT210 - Synchronised, adjustable / FT210 - For sensitive edges

- F210B - BlueBUS

FT210B - For sensitive edges, BlueBUS

##### Flashing light

ELAC

- ELDC

- WLT - Multifunction LED light

\* Radio receiver not compatible with the O-box functions of the Opera system.

Nice

# Hyke

**For swing gates with leaves up to 3.5 m, including with large posts.**

Ideal for intensive use.



Also available in a KIT



Adjustable anti-shear arm

Integrated control unit

Convenient and resistant release handle

Die-cast aluminium body

Non-reversible electromechanical gearmotor, with articulated arm, surface mounted, 24 VDC, with magnetic encoder.

**Reliable and with a long working life:** weather resistant, thanks to the polyester painted aluminium body.

**Safe:** obstacle detection, monitoring of motor draw during travel, self-diagnostics via LED courtesy light and flashing light.

Provision for connecting latest generation 8.2 KOhm optical and resistive sensitive edges.

**Two non-reversible** versions, 24 VDC, with opening and closing limit switches: with integrated control unit (HK7024) and without control unit (HK7224).

**Quick and practical installation:** the length of the articulated arm can be adjusted for maximum flexibility.

**Simple and precise limit switch adjustment:** mechanical stops and micrometric adjustment screws.

**Easy to operate lever release:** with metal lock and personalised Nice key. Provision for cable control.

**Savings, respect for the environment, autonomy:** connected to the buffer battery or the Solemyo kit, the stand-by consumption is < 0.25W.

**No blackouts:** operation in event of power failure with the optional batteries (PSS124) housed in the motor.

**Integrated control unit (HK7024).**

BlueBus

BiDi

Programmable via App

24V

Yubii

With Pro-View or Bidi-WiFi & MyNice Pro App.

Solemyo

Opera



Code	Description	Pcs./Pallet
<b>HK7024</b>	Non-reversible, 24 VDC, complete with articulated arm, with integrated control unit	15
<b>HK7224</b>	Non-reversible, 24 VDC, complete with articulated arm, without control unit	15
<b>HYKEBDKCE</b>	Kit for automating swing gates with leaves up to 3.5 m, 24 VDC, with articulated arm, surface mounted, with bidirectional technology	15



#### The HYKEBDKCE kit contains:

Code	Description	Quantity
<b>HK7024</b>	Electromechanical gearmotor, surface mounted, with control unit and OXIBD plug-in bidirectional radio receiver included	1
<b>HK7224</b>	Electromechanical gearmotor, surface mounted, without control unit	1
<b>MYGO4</b>	4-channel 433.92 MHz transmitter	2
<b>EPMB</b>	Pair of surface mounted photocells with provision for connection via Nice BlueBUS	1
<b>ELDC</b>	Flashing LED light with integrated antenna	1
<b>TS</b>	Sign	1

**N.B.** The contents of the pack may vary: always consult the dealer.

#### COMMON ACCESSORIES

Code	Description	Pcs. Pack
<b>SPHKA2R30</b>	Spare control unit for HK7024	1
<b>PSS124</b>	24 V battery with integrated battery charger	1
<b>PLA10</b>	Vertical 12 V electric lock (obligatory for leaves longer than 3 m)	1
<b>PLA11</b>	Horizontal 12 V electric lock (obligatory for leaves longer than 3 m)	1
<b>KIO</b>	Key switch for low-voltage contacts, with release mechanism for metal cable	1
<b>KA1</b>	Kit with 6 m metal cable for KIO	1
<b>SYKCE30</b>	Solar power supply kit consisting of SYP30 photovoltaic panel, PSY24 battery box with charging control circuit and SYA1 charger	1
<b>TS</b>	Sign	1

Find out more on page → 88.

#### TECHNICAL SPECIFICATIONS

Code	<b>HK7024</b>	<b>HK7224</b>
<b>ELECTRICAL SPECIFICATIONS</b>		
Power supply (VAC 50/60 Hz)	230	-
Power supply (VDC)	-	24
Draw (A)	1,5	6
Power (W)	300	140
Standby power (W)	< 0.25	

#### PERFORMANCE DATA

Speed (rpm)	1,5
Torque (Nm)	500
Working cycle (cycles/hour)	40

#### DIMENSIONAL AND GENERAL DATA

Protection class (IP)	54
Operating temperature (°C Min/Max)	-20 ÷ +50
Dimensions (mm)	290x210x320 h
Weight (kg)	10,5

#### OPERATING LIMITS

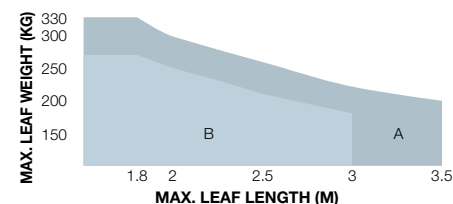
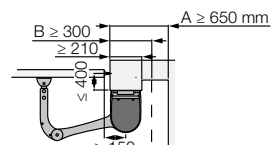

**A** Full arm - **B** Reduced arm  
The shape and height of the gate and presence of a strong wind can considerably reduce the values shown in the graph.

#### DIMENSIONS

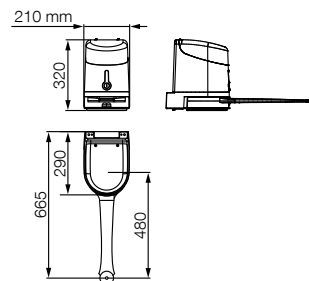

#### COMPATIBILITY WITH CONTROL SYSTEMS AND ACCESSORIES

**HK7024**

##### Control unit/Receiver

###### Integrated\*

- OXIBD / OXILR

##### Transmitter

- ERA INTI - 2 channels, 433.92 MHz, different colours
- ERA ONE / MYGO - 2, 4 or 8 channels, 433.92 MHz
- MYGOBD / ERA ONE LR
- DOMI

##### Photocells

- EPS - Slim / EPM - Medium / EPL - Large
- EPSB - Slim, BlueBUS / EPMB - Medium, BlueBUS / EPLB - Large, BlueBUS

##### EPMOR - Medium, reflective

- EPMORB - Medium, BlueBUS, reflective
- EPMOW - Medium, wireless self-synchronised

##### F210 - Synchronised, adjustable / FT210 - For sensitive edges

- F210B - BlueBUS

##### FT210B - For sensitive edges, BlueBUS

##### Flashing light

###### ELAC

- ELDC
- WLT - Multifunction LED light

\* Radio receiver not compatible with the O-box functions of the Opera system.

Nice

# Hyppo 7000

For swing gates with leaves up to 3 m, including with large posts.

Non-reversible electromechanical gearmotor, also available in 24 VDC version, with magnetic encoder and articulated arm, surface mounted.

Single version for right or left leaf.

Two non-reversible models, powered at 230 VAC (HY7005) and 24 VDC (HY7024), with magnetic encoder.

**Quick and easy installation:** thanks to fewer connections, no welding to the gate.

**Pre-wired built-in double limit switch** in both opening and closing (HY7005).

**Long working life:** 100% metal mechanics.

**Compact:** shockproof body with no sharp edges.

**Recommended control units:** Moonclever MC800 for HY7005; Moonclever MC824H for HY7024.

**24 VDC** version with magnetic encoder.

**Ideal for intensive use.**



Cast aluminium key release, with protected key, provision for release from outside

Sturdy anti-shear articulated arm, galvanised and painted; reinforced at points subject to greatest mechanical stress

BlueBus

BiDi

Programmable via App

24V

Yubii

With Pro-View or Bidi-WiFi & MyNice Pro App.

230V

Solemyo

Opera



Code	Description	Pcs./Pallet
<b>HY7024</b>	Non-reversible, 24 VDC, with magnetic encoder, complete with anti-shear articulated arm, galvanised and painted	30
<b>HY7005</b>	Non-reversible, 230 VAC, complete with anti-shear articulated arm, galvanised and painted, with limit switches in opening and closing	30

#### COMMON ACCESSORIES

Code	Description	Pcs. Pack
<b>HYA12</b>	Enlarged articulated arm (see diagram)	1
<b>PLA10</b>	Vertical 12 V electric lock	1
<b>PLA11</b>	Horizontal 12 V electric lock	1
<b>KIO</b>	Key switch for low-voltage contacts, with release mechanism for metal cable	1
<b>KA1</b>	Kit with 6 m metal cable for KIO	1
<b>TS</b>	Sign	1

#### ACCESSORIES FOR 24 V VERSIONS

Code	Description	Pcs. Pack
<b>PSS324</b>	24 V battery with integrated battery charger	1
<b>SYKCE30</b>	Solar power supply kit consisting of SYP30 photovoltaic panel, PSY24 battery box with charging control circuit and SYA1 charger	1

Find out more on page → 88.

#### TECHNICAL SPECIFICATIONS

Code	HY7024	HY7005
<b>ELECTRICAL SPECIFICATIONS</b>		
Power supply (VAC 50 Hz)*	-	230
Power supply (VDC)	24	-
Draw (A)	5	1,2
Power (W)	120	258
<b>PERFORMANCE DATA</b>		
Speed (rpm)	2	1,7
Torque (Nm)	250	400
Work cycle (%)	80	30
<b>DIMENSIONAL AND GENERAL DATA</b>		
Protection class (IP)		43
Operating temperature (°C Min/Max)		-20 ÷ +50
Dimensions (mm)		350x165x242 h
Weight (kg)		13

\* 60 Hz version available on request.

#### OPERATING LIMITS

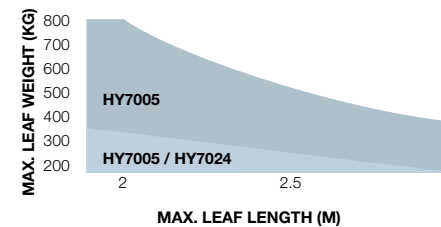
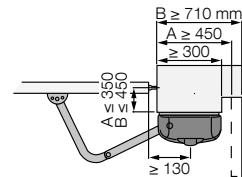

**A** Standard arm - **B** HYA12 accessory arm  
The shape and height of the gate and presence of a strong wind can considerably reduce the values shown in the graph. The 230 VAC models are best for windy areas.

#### DIMENSIONS

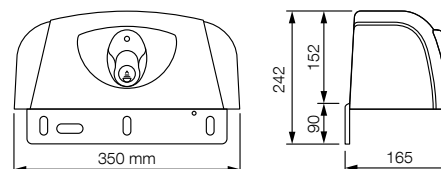

#### COMPATIBILITY WITH CONTROL SYSTEMS AND ACCESSORIES

HY7024  
HY7005

##### Control unit/Receiver

##### Integrated\*

- **MC824H / OXIBD / OXILR**
- **MC800 / OXIBD / OXILR**

##### Transmitter

- **ERA INTI** - 2 channels, 433.92 MHz, different colours
- **ERA ONE / MYGO** - 2, 4 or 8 channels, 433.92 MHz
- **MYGOBD / ERA ONE LR**
- **DOMI**

##### Photocells

- **EPS** - Slim / **EPM** - Medium / **EPL** - Large
- **EPSB** - Slim, BlueBUS / **EPMB** - Medium, BlueBUS / **EPLB** - Large, BlueBUS
- **EPMOR** - Medium, reflective
- **EPMORB** - Medium, BlueBUS, reflective
- **EPMOW** - Medium, wireless self-synchronised
- **F210** - Synchronised, adjustable / **FT210** - For sensitive edges
- **F210B** - BlueBUS
- **FT210B** - For sensitive edges, BlueBUS

##### Flashing light

- **ELAC**
- **ELDC**
- **WLT** - Multifunction LED light

\* Radio receiver not compatible with the O-box functions of the Opera system.

Nice

# S-Fab

For swing gates with leaves up to 2.3 m, underground installation, very compact.



Also available in a KIT



Electrophoretic painted steel box

Waterproof, IP67 protection class

Electromechanical gearmotor, non-reversible, 24 VDC, ideal for intensive use.

**Resistant and inconspicuous:** compact foundation box just 81 mm high.

The electrophoretic painted steel guarantees high corrosion resistance, the 2.5 mm thickness provides solidity. All this with just 52 mm protruding from the ground.

**Quick and easy installation:** thanks to the lever on the gearmotor acting directly on the leaf.

**Opening up to 180° as standard.**

**Reliable and sturdy:** the IP67 die-cast aluminium gearmotor is suspended inside the box to allow any deposits to drain for guaranteed water resistance.

**Self-supporting foundation box** with adjustable mechanical stops in opening and closing: the gearmotor can also be installed at a later date.

**Practical release** from inside and outside, acting directly on the gearmotor, easy to operate with the special key.

**SFAB2024 is compatible with the Moonclever MC424L control unit, with provision for Solemyo and Opera systems.**

**SFAB2124 with magnetic encoder, compatible with the Moonclever MC824H control unit, with BlueBUS technology and provision for Solemyo and Opera systems.**

BlueBus

BiDi

Programmable via App

24V

Yubii

With Pro-View or Bidi-WiFi & MyNice Pro App.

Solemyo

Opera



Code	Description	Pcs./Pallet
<b>SFAB2024</b>	Non-reversible, 24 VDC	18
<b>SFAB2124</b>	Non-reversible, 24 VDC, with magnetic encoder	18
<b>SFABBOX</b>	Electrophoretic painted steel foundation box. Complete with leaf attachment lever and mechanical stops in opening and closing	18
<b>SFAB2024BDKCE</b>	Kit for automating swing gates with leaves up to 2.3 m, 24 VDC, underground installation, with bidirectional technology	18
<b>SFAB2124BDKCE</b>	Kit for automating swing gates with leaves up to 2.3 m, 24 VDC, underground installation, with bidirectional technology and magnetic encoder	18

**The SFAB2024BDKCE kit contains:**

Code	Description	Quantity
<b>SFAB2024</b>	24 VDC non-reversible electromechanical gearmotor	2
<b>SFABBOX</b>	Foundation boxes	2
<b>MC424L</b>	Control unit with integrated radio receiver	1
<b>INTI2</b>	Transmitter, 433.92 MHz, 2 channels	2
<b>EPM</b>	Pair of surface mounted photocells	1
<b>ELDC</b>	Flashing LED light with integrated antenna	1
<b>TS</b>	Sign	1

N.B. The contents of the pack may vary: always consult the dealer.

**The SFAB2124BDKCE kit contains:**

Code	Description	Quantity
<b>SFAB2124</b>	Non-reversible electromechanical gearmotor, 24 VDC, with magnetic encoder	2
<b>SFABBOX</b>	Foundation boxes	2
<b>MC824H</b>	Control unit with OXIBD plug-in bidirectional radio receiver included	1
<b>MYGO4</b>	4-channel 433.92 MHz transmitter	2
<b>EPMB</b>	Pair of surface mounted photocells with provision for connection via Nice BlueBUS	1
<b>ELDC</b>	Flashing LED light with integrated antenna	1
<b>TS</b>	Sign	1

N.B. The contents of the pack may vary: always consult the dealer.

**COMMON ACCESSORIES**

Code	Description	Pcs. Pack
<b>PSS124</b>	24 V battery with integrated battery charger for SFAB2024	1
<b>PSS324</b>	24 V battery with integrated battery charger for SFAB2124	1
<b>MEA5</b>	Lever key for release	4
<b>PLA10</b>	Vertical 12 V electric lock	1
<b>PLA11</b>	Horizontal 12 V electric lock	1
<b>SYKCE30</b>	Solar power supply kit consisting of SYP30 photovoltaic panel, PSY24 battery box with charging control circuit and SYA1 charger	1
<b>TS</b>	Sign	1

Find out more on page → 88.

**TECHNICAL SPECIFICATIONS**

Code	SFAB2024	SFAB2124
<b>ELECTRICAL SPECIFICATIONS</b>		
Power supply (VDC)	24	
Draw (A)	5	
Power (W)	120	
<b>PERFORMANCE DATA</b>		
Speed (rpm)	1,25	
Torque (Nm)	250	
Working cycle (cycles/hour)*	60	
<b>DIMENSIONAL AND GENERAL DATA</b>		
Protection class (IP)	67	
Operating temperature (°C Min/Max)	-20 ÷ +50	
Dimensions (mm)	235x206x96,5 h	
Weight (kg)	6	

\* The indicated value must be halved in the case of opening up to 180°.

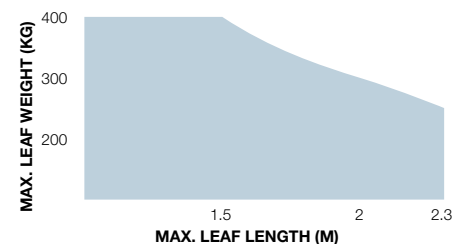
**OPERATING LIMITS**

The shape and height of the gate and presence of a strong wind can considerably reduce the values shown in the graph.

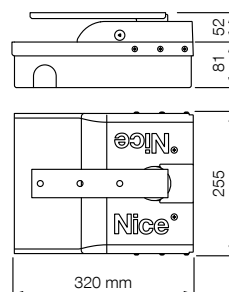
**DIMENSIONS**

**COMPATIBILITY WITH CONTROL SYSTEMS AND ACCESSORIES**

SFAB2024	SFAB2124
<b>Control unit/Receiver</b>	
<b>Integrated*</b>	
<ul style="list-style-type: none"> <li>• <b>MC424L / OXIBD / OXILR</b></li> <li>• <b>MC824H / OXIBD / OXILR</b></li> </ul>	
<b>Transmitter</b>	
<ul style="list-style-type: none"> <li>• <b>ERA INTI</b> - 2 channels, 433.92 MHz, different colours</li> <li>• <b>ERA ONE / MYGO</b> - 2, 4 or 8 channels, 433.92 MHz</li> <li>• <b>MYGOBD / ERA ONE LR</b></li> </ul>	
<b>DOMI</b>	
<b>Photocells</b>	
<ul style="list-style-type: none"> <li>• <b>EPS</b> - Slim / <b>EPM</b> - Medium / <b>EPL</b> - Large</li> <li>• <b>EPSB</b> - Slim, BlueBUS / <b>EPMB</b> - Medium, BlueBUS / <b>EPLB</b> - Large, BlueBUS</li> <li>• <b>EPMOR</b> - Medium, reflective</li> <li>• <b>EPMORB</b> - Medium, BlueBUS, reflective</li> <li>• <b>EPMOW</b> - Medium, wireless self-synchronised</li> </ul>	
<ul style="list-style-type: none"> <li>• <b>F210</b> - Synchronised, adjustable / <b>FT210</b> - For sensitive edges</li> <li>• <b>F210B</b> - BlueBUS</li> <li>• <b>FT210B</b> - For sensitive edges, BlueBUS</li> </ul>	
<b>Flashing light</b>	
<b>ELAC</b>	
<ul style="list-style-type: none"> <li>• <b>ELDC</b></li> <li>• <b>WLT</b> - Multifunction LED light</li> </ul>	

\* Radio receiver not compatible with the O-box functions of the Opera system.

Nice

# M-Fab

For swing gates with leaves up to 3 m, concealed underground installation.



Also available in a KIT

Even more reliable and resistant



Waterproof, IP67 protection class

FAB BOX foundation boxes

Non-reversible electromechanical gearmotor, also available in 24 VDC version, with magnetic encoder.

**3 versions of M-Fab gearmotor.**

**Moulded Fab Box** foundation boxes with mechanical stop in opening:

- **in stainless steel** (MFABBOXI), ideal for use in extreme conditions;
- **electrophoretic painted** (MFABBOX), with high resistance to corrosion.

**Reliable and resistant:** motors with solid metal internal components. New IP67 waterproof die-cast aluminium.

**Maximum freedom of choice:** release from inside and outside, two freely combinable key or lever-operated models, easy to operate with one hand.

**Easy to use:** mechanical stop system in closing. Standard 110° opening, 360° optional.

**Totally compatible** with the previous Metro series.

**Recommended control units:** Moonclever MC800 for MFAB3000 and MFAB3000L; Moonclever MC824H for MFAB3024.

**24 VDC version with magnetic encoder.**

**Ideal for intensive use.**

BlueBus

BiDi

Programmable via App

24V

Yubii

With Pro-View or Bidi-WiFi & MyNice Pro App.

230V

Solemyo

Opera



Code	Description	Pcs./Pallet
<b>MFAB3024</b>	Non-reversible, 24 VDC, with magnetic encoder, complete with connecting lever and mechanical stop in closing	18
<b>MFAB3000</b>	Non-reversible, 230 VAC, fast, grease lubricated, complete with connecting lever and mechanical stop in closing	18
<b>MFAB3000L</b>	Non-reversible, 230 VAC, slow, grease lubricated, complete with connecting lever and mechanical stop in closing	18
<b>MFAB3024BDKCE</b>	Kit for automating swing gates with leaves up to 3 m, embedded underground installation. The kit contains 2 x MFAB3024, 1 x MC824H, 2 x MEA3, 2 x MYGO4, 1 x EPMB, 1 x ELDC, 1 x TS.	9
Code	Description	Pcs./Pallet
<b>MFABBOXI</b>	Externally chamfered stainless steel foundation box with mechanical stop in opening	20
<b>MFABBOX</b>	Electrophoretic painted, externally chamfered foundation box with mechanical stop in opening	20

**NOTE:** key release freely combinable, choosing between models MEA2 and MEA3.

#### The MFAB3024BDKCE kit contains:

Code	Description	Quantity
<b>MFAB3024</b>	Non-reversible electromechanical gearmotor, 24 VDC, with magnetic encoder (foundation boxes to be ordered separately)	2
<b>MC824H</b>	Control unit with OXIBD plug-in bidirectional radio receiver included	1
<b>MEA3</b>	Lever key release for use when installing on surfaces such as sand or earth	2
<b>MYGO4</b>	4-channel 433.92 MHz transmitter	2
<b>EPMB</b>	Pair of surface mounted photocells with provision for connection via Nice BlueBUS	1
<b>ELDC</b>	Flashing LED light with integrated antenna	1
<b>TS</b>	Sign	1

\* **N.B.** The contents of the pack may vary: always consult the dealer.

#### COMMON ACCESSORIES

Code	Description	Pcs. Pack
<b>PSS324</b>	24 V battery with integrated battery charger	1
<b>MEA2</b>	Key release	1
<b>MEA3</b>	Lever key release for use when installing on surfaces such as sand or earth	1
<b>MEA5</b>	Lever key for release	4
<b>MEA6</b>	Limit bracket, for installations where the foundation box cannot be embedded in concrete	4
<b>MEA1</b>	Accessory for opening up to 360° for leaves up to 2.5 m long	4
<b>PLA10</b>	Vertical 12 V electric lock	1
<b>PLA11</b>	Horizontal 12 V electric lock	1
<b>SYKCE30</b>	Solar power supply kit consisting of SYP30 photovoltaic panel, PSY24 battery box with charging control circuit and SYA1 charger	1
<b>TS</b>	Sign	1

Find out more on page → 88.

#### TECHNICAL SPECIFICATIONS

Code	MFAB3024	MFAB3000	MFAB3000L
<b>ELECTRICAL SPECIFICATIONS</b>			
Power supply (VAC 50 Hz)*	-	230	
Power supply (VDC)	24	-	
Draw (A)	5	1,2	1,3
Power (W)	120	250	300
<b>PERFORMANCE DATA</b>			
Speed (rpm)	1,4	1,14	0,8
Torque (Nm)	250	300	250
Working cycle (cycles/hour)**	76	30	20
<b>DIMENSIONAL AND GENERAL DATA</b>			
Protection class (IP)	67		
Operating temperature (°C Min/Max)	-20 ÷ +50		
Dimensions (mm)	390x322x194,5 h		
Weight (kg)	11		

\* 60 Hz version available on request. \*\* The indicated value must be halved in the case of opening up to 180°.

#### OPERATING LIMITS

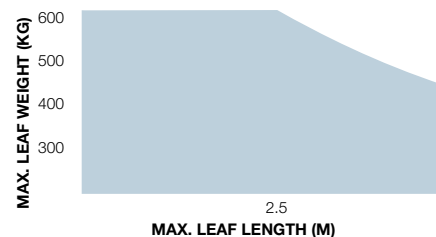

The shape and height of the gate and presence of a strong wind can considerably reduce the values shown in the graph. The 230 VAC models are best for windy areas.

#### DIMENSIONS

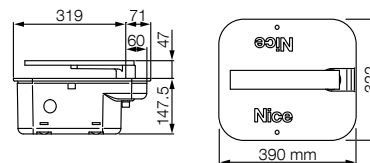

#### COMPATIBILITY WITH CONTROL SYSTEMS AND ACCESSORIES

MFAB3024 MFAB3000 MFAB3000L	<b>Control unit/Receiver</b>
	<b>Integrated*</b>
	<ul style="list-style-type: none"> <li>• <b>MC824H / OXIBD / OXILR</b></li> <li>• • <b>MC800* / OXIBD / OXILR</b></li> </ul>
	<b>Transmitter</b>
	<ul style="list-style-type: none"> <li>• • • <b>ERA INTI</b> - 2 channels, 433.92 MHz, different colours</li> <li>• • • <b>ERA ONE / MYGO</b> - 2, 4 or 8 channels, 433.92 MHz</li> <li>• • • <b>MYGOBD / ERA ONE LR</b></li> <li>• • • <b>DOMi</b></li> </ul>
	<b>Photocells</b>
	<ul style="list-style-type: none"> <li>• • <b>EPS</b> - Slim / <b>EPM</b> - Medium / <b>EPL</b> - Large</li> <li>• • • <b>EPSB</b> - Slim, BlueBUS / <b>EPMB</b> - Medium, BlueBUS / <b>EPLB</b> - Large, BlueBUS</li> <li>• • <b>EPMOR</b> - Medium, reflective</li> <li>• • • <b>EPMORB</b> - Medium, BlueBUS, reflective</li> <li>• • • <b>EPMOW</b> - Medium, wireless self-synchronised</li> <li>• • • <b>F210</b> - Synchronised, adjustable / <b>FT210</b> - For sensitive edges</li> <li>• • • <b>F210B</b> - BlueBUS</li> <li>• • <b>FT210B</b> - For sensitive edges, BlueBUS</li> </ul>
	<b>Flashing light</b>
	<ul style="list-style-type: none"> <li>• • <b>ELAC</b></li> <li>• <b>ELDC</b></li> <li>• <b>WLT</b> - Multifunction LED light</li> </ul>

\* Radio receiver not compatible with the O-box functions of the Opera system.

Nice

# L-Fab

For swing gates with leaves up to 4 m, concealed underground installation.

Reliable and resistant



Waterproof, IP67 protection class

Non-reversible electromechanical gearmotor, also available in 24 VDC version, with magnetic encoder and mechanical stops.

**Foundation boxes** with mechanical stop in opening:

- **in stainless steel** (LFABBOX4I), ideal for use in extreme conditions;
- **electrophoretic painted** (LFABBOX4), with high resistance to corrosion.

**Maximum freedom of choice:** release from inside and outside, two freely combinable key or lever-operated models, easy to operate with one hand.

**Simple installation:** mechanical stop system in closing integrated in motor. Standard 110° opening, 360° optional.

**Ideal for intensive use, the LFAB4024 model is compatible with the Moonclever MC824H control unit, with BlueBUS technology and provision for Solemyo and Opera systems.**

The LFAB4000 is compatible with the Moonclever MC800 control unit.

BlueBus

BiDi

Programmable via App

24V

Yubii

With Pro-View or Bidi-WiFi & MyNice Pro App.

230V

Solemyo

Opera



Code	Description	Pcs./Pallet
<b>LFAB4000</b>	Non-reversible, 230 VAC, with mechanical limit switch in closing	18
<b>LFAB4024</b>	Non-reversible, 24 VDC, with magnetic encoder and mechanical limit switch in closing	18

Code	Description	Pcs./Pallet
<b>LFABBOX4</b>	Electrophoretic painted foundation box with mechanical limit switch in opening. Complete with leaf attachment lever	18
<b>LFABBOX4I</b>	Stainless steel foundation box with mechanical limit switch in opening. Complete with leaf attachment lever	18

#### COMMON ACCESSORIES

Code	Description	Pcs. Pack
<b>BMA3</b>	Release with lever key	1
<b>MEA5</b>	Lever key for release	4
<b>BMA1</b>	Accessory for opening up to 360° for leaves up to 3.5 m long	1
<b>BMA2</b>	Adapter for installing two motors, compatible with most foundation boxes on the market	4
<b>PLA10</b>	Vertical 12 V electric lock	1
<b>PLA11</b>	Horizontal 12 V electric lock	1
<b>TS</b>	Sign	1

#### ACCESSORIES FOR 24 V VERSIONS

Code	Description	Pcs. Pack
<b>PSS324</b>	24 V battery with integrated battery charger	1
<b>SYKCE30</b>	Solar power supply kit consisting of SYP30 photovoltaic panel, PSY24 battery box with charging control circuit and SYA1 charger	1

Find out more on page → 88.

#### TECHNICAL SPECIFICATIONS

Code	LFAB4024	LFAB4000
<b>ELECTRICAL SPECIFICATIONS</b>		
Power supply (VAC 50/60 Hz)*	-	230
Power supply (VDC)	24	-
Draw (A)	5	1,5
Power (W)	120	340
<b>PERFORMANCE DATA</b>		
Speed (rpm)	1	0,8
Torque (Nm)	300	500
Working cycle (cycles/hour)**	60	20

#### DIMENSIONAL AND GENERAL DATA

Protection class (IP)	67	
Operating temperature (°C Min/Max)	-20 ÷ +50	
Dimensions (mm)	400x325x152 h	
Weight (kg)	12,5	14,3

\* With foundation box. \*\* The value indicated must be halved in the case of opening up to 180° - using the BMA1 accessory.

<b>Foundation box</b>	<b>LFABBOX4</b>
Weight (kg)	14,4

#### OPERATING LIMITS

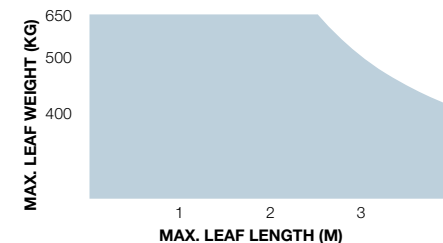

The shape and height of the gate and presence of a strong wind can considerably reduce the values shown in the graph. The 230 VAC models are best for windy areas.

#### DIMENSIONS

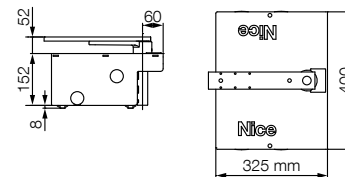

#### COMPATIBILITY WITH CONTROL SYSTEMS AND ACCESSORIES

<b>LFAB4000</b>	<b>Control unit/Receiver</b>
	<b>Integrated*</b>
<b>LFAB4024</b>	<ul style="list-style-type: none"> <li>• <b>MC824H / OXIBD / OXILR</b></li> <li>• <b>MC800* / OXIBD / OXILR</b></li> </ul>
	<b>Transmitter</b>
	<ul style="list-style-type: none"> <li>• <b>ERA INTI</b> - 2 channels, 433.92 MHz, different colours</li> <li>• <b>ERA ONE / MYGO</b> - 2, 4 or 8 channels, 433.92 MHz</li> <li>• <b>MYGOBD / ERA ONE LR</b></li> <li>• <b>DOMi</b></li> </ul>
	<b>Photocells</b>
	<ul style="list-style-type: none"> <li>• <b>EPS</b> - Slim / <b>EPM</b> - Medium / <b>EPL</b> - Large</li> <li>• <b>EPSB</b> - Slim, BlueBUS / <b>EPMB</b> - Medium, BlueBUS / <b>EPLB</b> - Large, BlueBUS</li> <li>• <b>EPMOR</b> - Medium, reflective</li> <li>• <b>EPMORB</b> - Medium, BlueBUS, reflective</li> <li>• <b>EPMOW</b> - Medium, wireless self-synchronised</li> <li>• <b>F210</b> - Synchronised, adjustable / <b>FT210</b> - For sensitive edges</li> <li>• <b>F210B</b> - BlueBUS</li> <li>• <b>FT210B</b> - For sensitive edges, BlueBUS</li> </ul>
	<b>Flashing light</b>
	<ul style="list-style-type: none"> <li>• <b>ELAC</b></li> <li>• <b>ELDC</b></li> <li>• <b>WLT</b> - Multifunction LED light</li> </ul>

\* Radio receiver not compatible with the O-box functions of the Opera system.

Nice

# Big-Fab

For swing gates with leaves up to 5 m, concealed underground installation.

Even more reliable  
and resistant



Waterproof, IP67  
protection class

Electromechanical gearmotor, 24 VDC, with magnetic encoder and mechanical stops.

**Foundation boxes** with mechanical stop in opening:

- **in stainless steel** (BFABBOXI), ideal for use in extreme conditions;
- **electrophoretic painted** (BFABBOX), with high resistance to corrosion.

**Maximum freedom of choice:** release from inside and outside, two freely combinable key or lever-operated models, easy to operate with one hand.

**Easy to use:** mechanical stop system in closing integrated in motor. Standard 110° opening, 360° optional.

**Ideal for intensive use,** compatible with Moonclever MC824H control unit.

BlueBus

BiDi

Programmable via  
App

24V

Yubii

With Pro-View or  
Bidi-WiFi & MyNice  
Pro App.

Solemyo

Opera



Code	Description	Pcs./Pallet
<b>BFAB5024</b>	Non-reversible, 24 VDC, with magnetic encoder and mechanical limit switch in closing	18

Code	Description	Pcs./Pallet
<b>BFABBOX</b>	Electrophoretic painted foundation box with mechanical limit switch in opening	18
<b>BFABBOXI</b>	Stainless steel foundation box with mechanical limit switch in opening	18

#### COMMON ACCESSORIES

Code	Description	Pcs. Pack
<b>PSS324</b>	24 V battery with integrated battery charger	1
<b>BMA3</b>	Release with lever key	1
<b>MEA5</b>	Lever key for release	4
<b>BMA1</b>	Accessory for opening up to 360° for leaves up to 3.5 m long	1
<b>BMA2</b>	Adapter for installing two motors, compatible with most foundation boxes on the market	4
<b>PLA10</b>	Vertical 12 V electric lock	1
<b>PLA11</b>	Horizontal 12 V electric lock	1
<b>SYKCE30</b>	Solar power supply kit consisting of SYP30 photovoltaic panel, PSY24 battery box with charging control circuit and SYA1 charger	1
<b>TS</b>	Sign	1

Find out more on page → 88.

#### TECHNICAL SPECIFICATIONS

Code	<b>BFAB5024</b>
<b>ELECTRICAL SPECIFICATIONS</b>	
Power supply (VDC)	24
Draw (A)	7
Power (W)	170
<b>PERFORMANCE DATA</b>	
Speed (rpm)	0,8
Torque (Nm)	400
Working cycle (cycles/hour)**	45
<b>DIMENSIONAL AND GENERAL DATA</b>	
Protection class (IP)	67
Operating temperature (°C Min/Max)	-20 ÷ +50
Dimensions (mm)*	400x325x152 h
Weight (kg)	13,3

\* With foundation box. \*\* The value indicated must be halved in the case of opening up to 180° - using the BMA1 accessory.

<b>Foundation box</b>	<b>BFABBOX</b>
Weight (kg)	20,3

#### OPERATING LIMITS

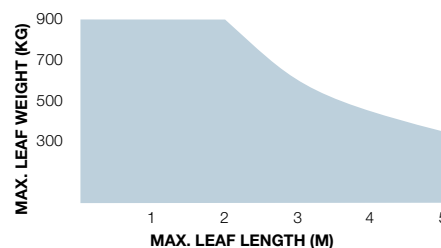

The shape and height of the gate and presence of a strong wind can considerably reduce the values shown in the graph.

#### DIMENSIONS

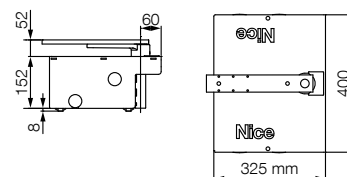

#### COMPATIBILITY WITH CONTROL SYSTEMS AND ACCESSORIES

BFAB5024

##### Control unit/Receiver

###### Integrated\*

- MC824H / OXIBD / OXILR

###### Transmitter

- ERA INTI - 2 channels, 433.92 MHz, different colours
- ERA ONE / MYGO - 2, 4 or 8 channels, 433.92 MHz
- MYGOBD / ERA ONE LR
- DOMI

###### Photocells

- EPS - Slim / EPM - Medium / EPL - Large
- EPSB - Slim, BlueBUS / EPMB - Medium, BlueBUS / EPLB - Large, BlueBUS
- EPMOR - Medium, reflective
- EPMORB - Medium, BlueBUS, reflective
- EPMOW - Medium, wireless self-synchronised
- F210 - Synchronised, adjustable / FT210 - For sensitive edges

- F210B - BlueBUS

FT210B - For sensitive edges, BlueBUS

###### Flashing light

###### ELAC

- ELDC
- WLT - Multifunction LED light

\* Radio receiver not compatible with the O-box functions of the Opera system.

# Accessories for swing gates

## COMMON ACCESSORIES



**PLA6**  
Rear bracket, length 250 mm (for Toona4, Toona5 and Wingo5).  
Pcs./pack 1



**PLA8**  
Screw-on front bracket (for Toona 5 and Wingo 5).  
Pcs./pack 1



**PLA10**  
Vertical 12 V electric lock.  
Pcs./pack 1



**PLA11**  
Horizontal 12 V electric lock.  
Pcs./pack 1



**PLA13**  
Mechanical limit switch for opening or closing (not compatible with TO7024).  
Pcs./pack 4



**PLA14**  
Adjustable screw-on rear bracket (for Toona 4 and Wingo 4).  
Pcs./pack 2



**PLA15**  
Adjustable screw-on front bracket (for Toona 4 and Wingo 4).  
Pcs./pack 2



**PLA16**  
Articulated rear bracket (for Toona 4 and 5).  
Pcs./pack. 1



**HYA12**  
Larger articulated arm (for Hyppo).  
Pcs./pack 1



**MEA1**  
Accessory for opening up to 360° for leaves up to 2.5 m long (for M-FAB).  
Pcs./pack 4



**MEA2**  
Key release (for M-FAB).  
Pcs./pack 1



**MEA3**  
Release with lever key for use when installing on surfaces such as sand or earth (for M-FAB).  
Pcs./pack 1



**MEA5**  
Lever key for release (compatible with all embedded motors).  
Pcs./pack 4



**MEA6**  
Limit bracket, for installations where the foundation box cannot be embedded in concrete (for M-FAB).  
Pcs./pack 4



**BMA3**  
Release with lever key (for L-Fab and Big-Fab).  
Pcs./pack 1



**BMA1**  
Accessory for opening up to 360° for leaves up to 3.5 m long (for L-Fab and Big-Fab).  
Pcs./pack 1



**BMA2**  
Adapters for installing two motors, compatible with most foundation boxes on the market (for L-Fab and Big-Fab).  
Pcs./pack 4



**KIO**  
Key switch for low-voltage contacts, with release mechanism for metal cable (for Hopp and Hyke).  
Pcs./pack 1



**KA1**  
6 m metal cable kit for KIO (for Hopp and Hyke).  
Pcs./pack 1



**WLT**  
Multifunction LED signal light. See page 203.  
Pcs./pack 1



**TS**  
Sign.  
Pcs./pack 1

## SPARE CONTROL UNITS



**WLA1**  
Spare control unit for WL1024C.

Pcs./pack 1



**PS424**  
Buffer batteries (for Walkykit).

Pcs./pack 1



**SPPOA3R30**  
Spare control unit for HO7124.

Pcs./pack 1



**SPHKA2R30**  
Spare control unit for HK7024.

Pcs./pack 1

## ACCESSORIES FOR 24 V VERSIONS



**PSS324**  
24 V battery with built-in battery charger (compatible with MC824H and MC824L control units. Kit only).

Pcs./pack 1



**PSS124**  
24 V battery with built-in battery charger (compatible with MC424L control unit, Hopp and Hyke Kit).

Pcs./pack 1



**SYKCE30**  
Solar power supply kit consisting of SYP30 photovoltaic panel and PSY24 battery box with charging control circuit and SYA1 power supply.

Pcs./pack 1

Solemyo

24V

## Standard installation diagram for swing gates

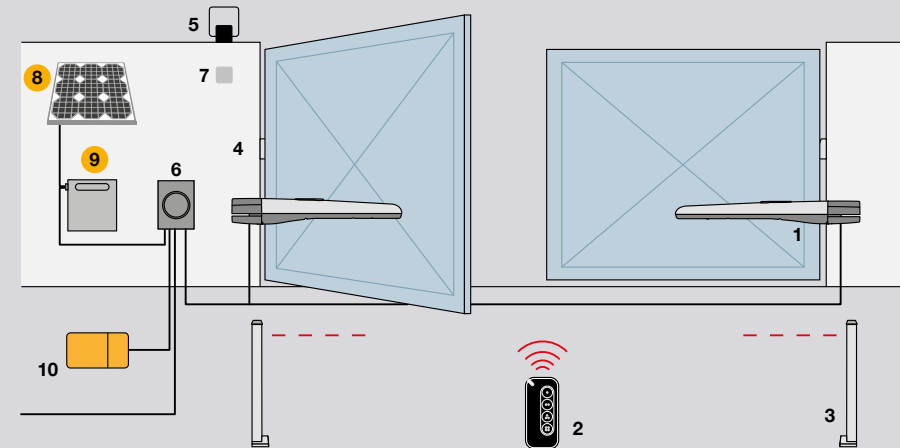

### TOONA 4, TOONA 5, TOONA 7

1. Motor 2. Transmitter 3. Post-mounted photocells 4. Photocells 5. Flashing light 6. Control unit 7. Key or digital switch 8. SYP30 solar panel 9. PSY24 battery box 10. Pro-View multifunction interface

● Solemyo solar power accessories

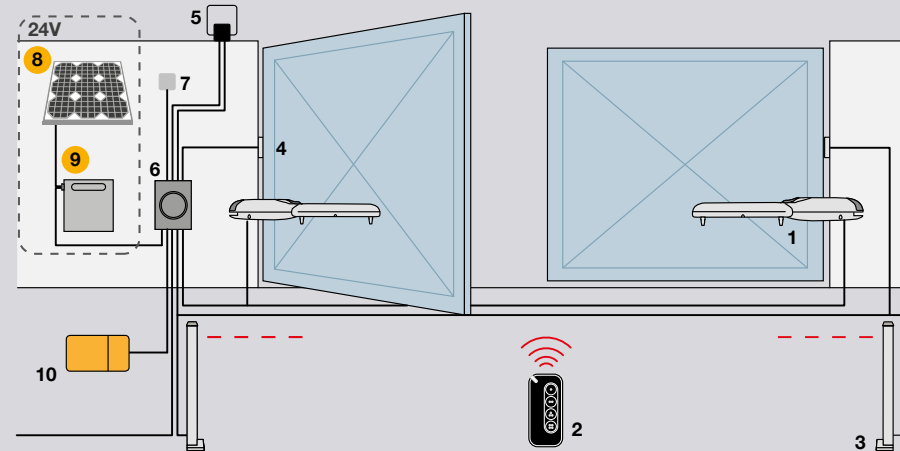

### WINGO 4, WINGO 5

1. Motor 2. Transmitter 3. Post-mounted photocells 4. Photocells 5. Flashing light 6. Control unit 7. Key or digital switch 8. SYP30 solar panel 9. PSY24 battery box 10. Pro-View multifunction interface

● Solemyo solar power accessories

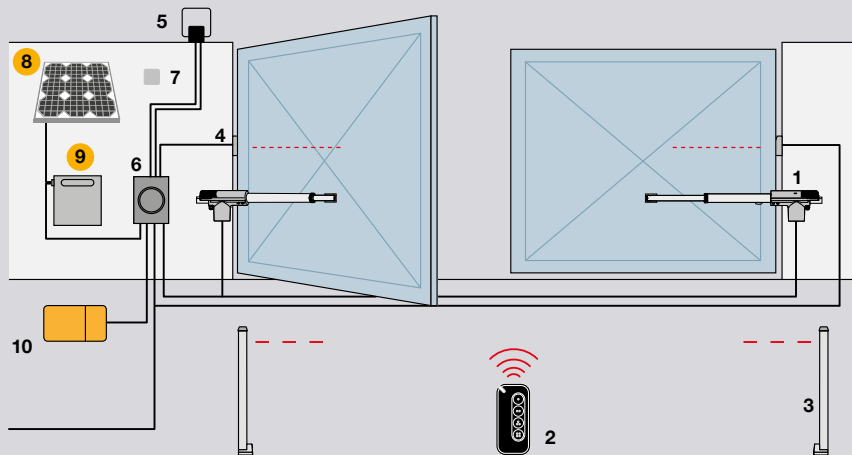

**TOO**

1. Motor 2. Transmitter 3. Post-mounted photocells 4. Photocells 5. Flashing light 6. Control unit 7. Key or digital switch 8. SYP30 solar panel 9. PSY24 battery box 10. Pro-View multifunction interface

● Solemyo solar power accessories (solely for Too 24V)

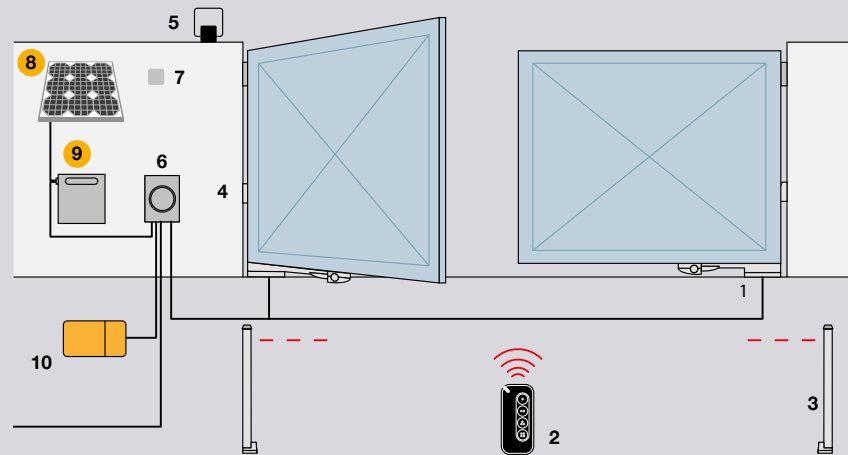

**OLTRE 1824**

1. Motor 2. Transmitter 3. Post-mounted photocells 4. Photocells 5. Flashing light 6. Control unit 7. Key or digital switch 8. SYP30 solar panel 9. PSY24 battery box 10. Pro-View multifunction interface

● Solemyo solar power accessories

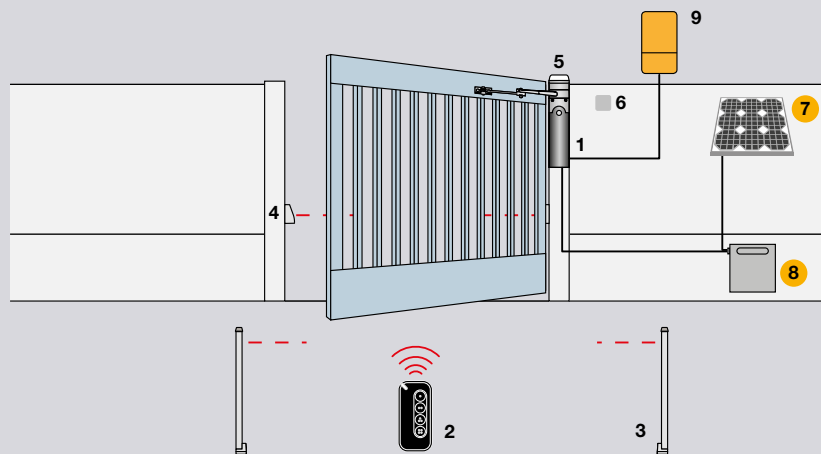

**WALKYKIT**

1. Motor 2. Transmitter 3. Post-mounted photocells 4. Photocells 5. Flashing light 6. Digital or key switch 7. SYP30 solar panel 8. PSY24 battery box 9. Pro-View multifunction interface

● Solemyo solar power accessories

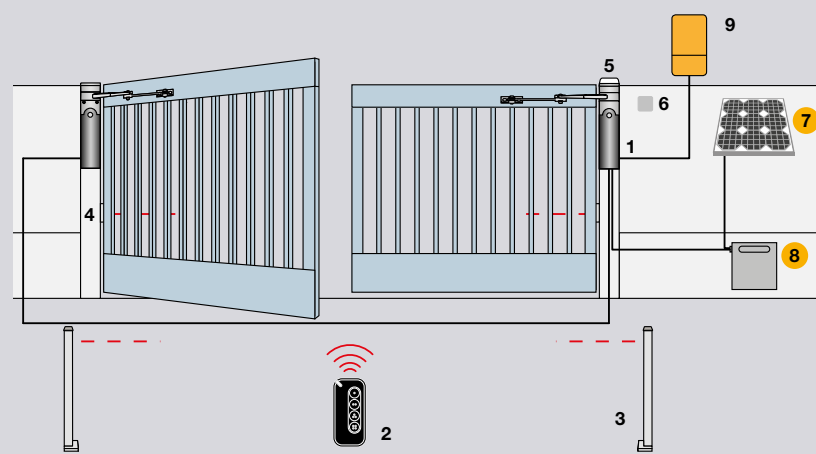

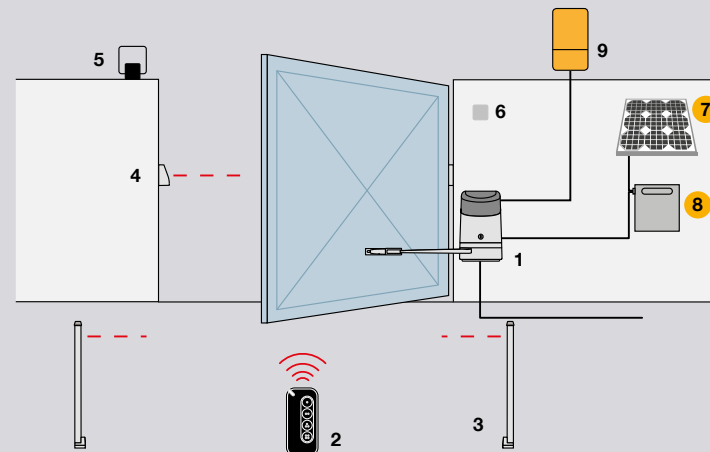
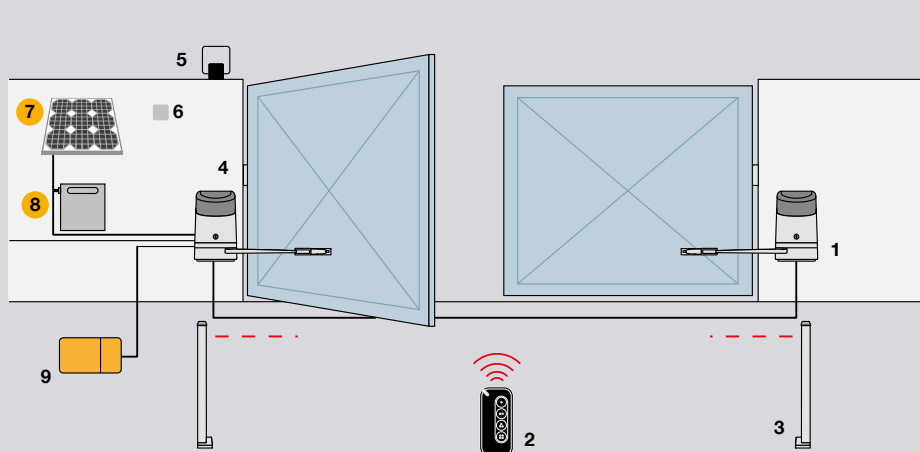

**HOPP**

1. Motor 2. Transmitter 3. Post-mounted photocells 4. Photocells 5. Flashing light  
6. Digital selector or key switch 7. SYP30 solar panel 8. PSY24 battery box 9. Pro-View multifunction interface (for PP7124 only)

● Solemyo solar power accessories

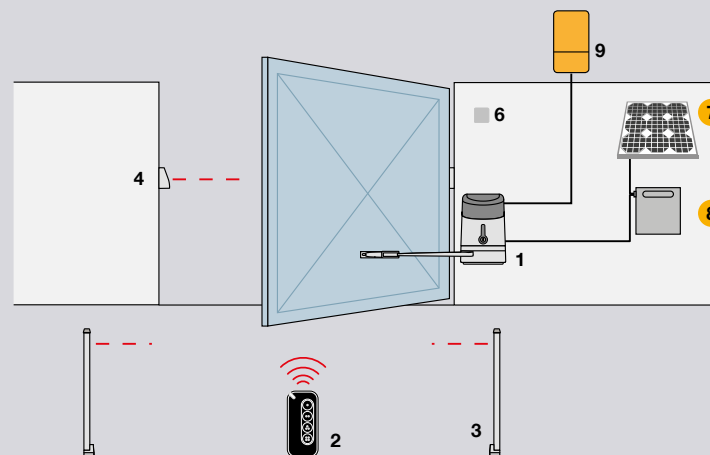
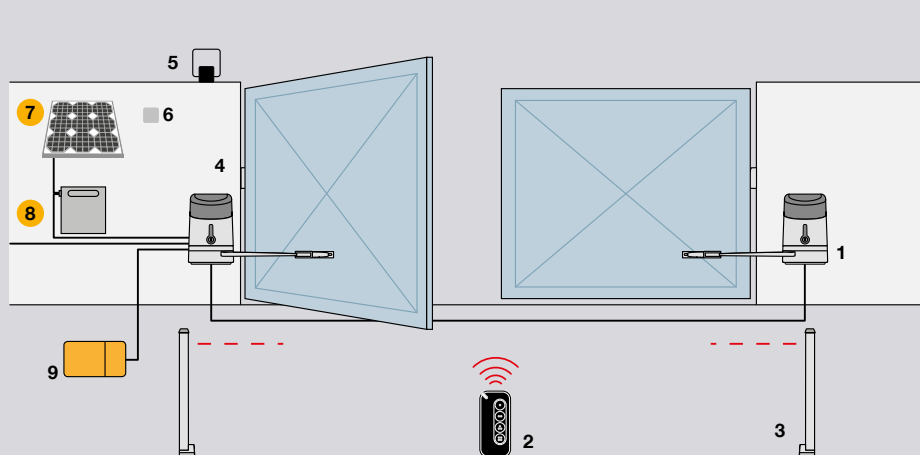

**HYKE**

1. Motor 2. Transmitter 3. Post-mounted photocells 4. Photocells 5. Flashing light  
6. Digital selector or key switch 7. SYP30 solar panel 8. PSY24 battery box 9. Pro-View multifunction interface (for PP7124 only)

● Solemyo solar power accessories

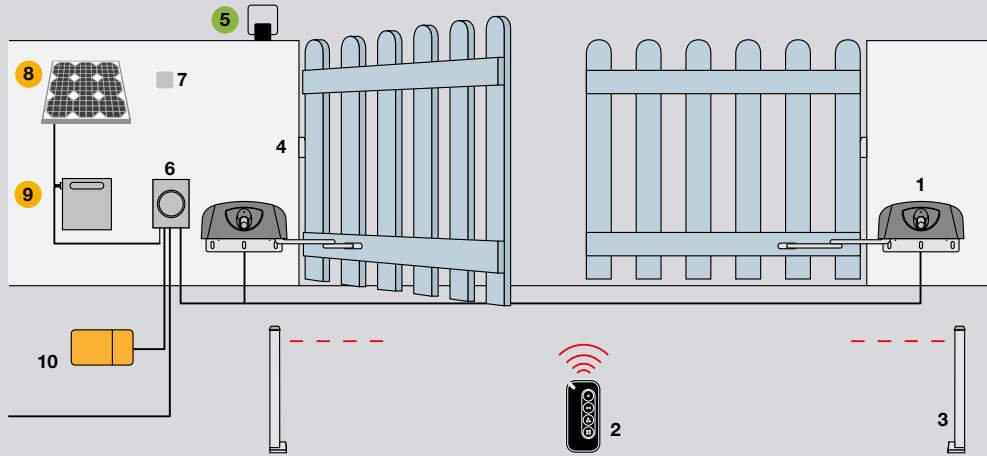

## HYPPO

1. Motor 2. Transmitter 3. Post-mounted photocells 4. Photocells 5. Flashing light 6. Control unit 7. Key or digital switch 8. SYP30 solar panel 9. PSY24 battery box 10. Pro-View multifunction interface

● Solemyo solar power accessories

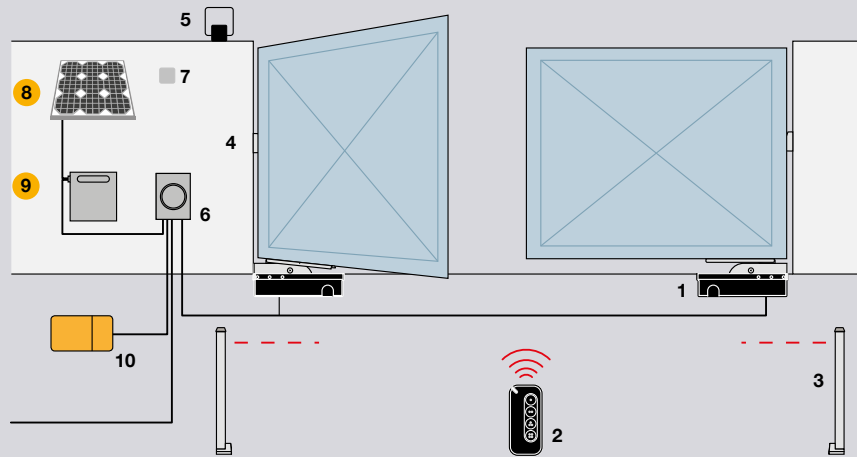

## S-FAB

1. Motor 2. Transmitter 3. Post-mounted photocells 4. Photocells 5. Flashing light 6. Control unit 7. Key or digital switch 8. SYP30 solar panel 9. PSY24 battery box 10. Pro-View multifunction interface

● Solemyo solar power accessories

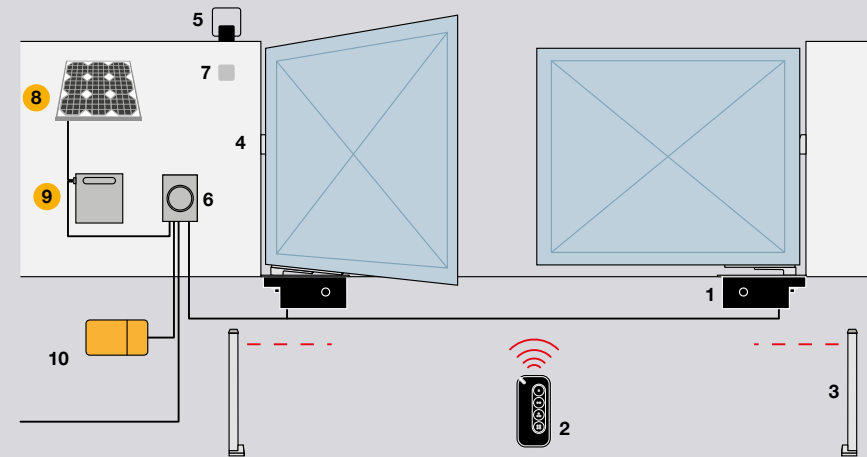

## M-FAB, L-FAB, BIG-FAB

1. Motor 2. Transmitter 3. Post-mounted photocells 4. Photocells 5. Flashing light 6. Control unit 7. Key or digital switch 8. SYP30 solar panel 9. PSY24 battery box 10. Pro-View multifunction interface

● Solemyo solar power accessories





Non-reversible, 24 VDC,  
with integrated control unit.  
For gates up to 400 kg,  
with leaves up to 6 m.

**Road**  
pages 106

**RDKCE**



Non-reversible, 230 VAC, electromechanical limit  
switch, control unit with integrated radio receiver.  
For sliding gates up to 600 kg.

**Robo 600**  
pages 108

→ **RO600**  
→ **RO600KCE**  
→ **RO600KLT**



Nice

# Selection guide

For residential and industrial use

Non-reversible, 24 Vdc, with integrated control unit. With BlueBUS technology, provision for Solemyo and Opera.

**Robus 1000**  
pagg. 104

for gates weighing up to 1000 kg

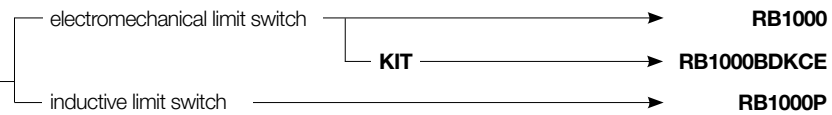

Non-reversible, 230 VAC, electromechanical limit switch, control unit with integrated radio receiver.

**Robo 1000/1500**  
pag. 110

New

for gates weighing up to 1000 kg

electromechanical limit switch

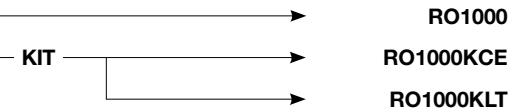

for gates weighing up to 1500 kg

electromechanical limit switch

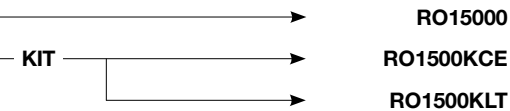

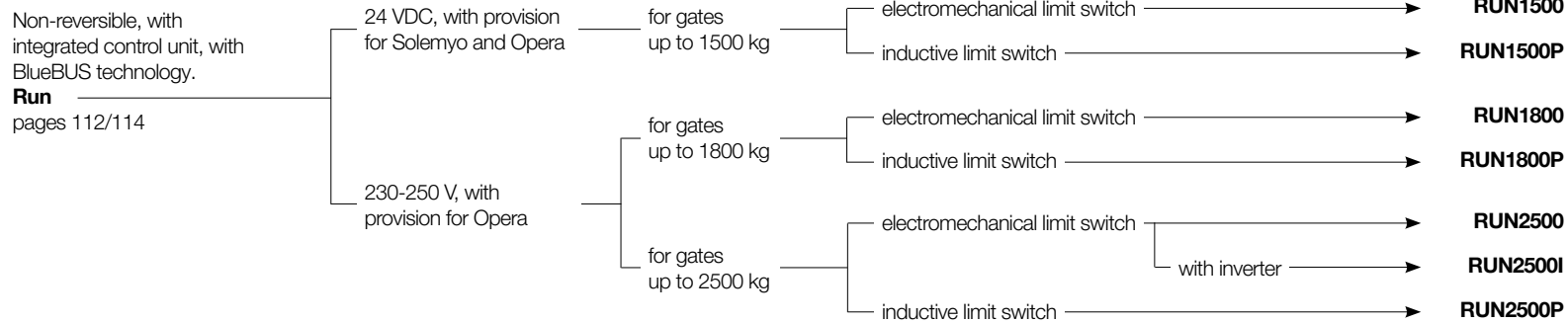

**For industrial use**



Nice

# Naked

The first concealed Nice motor for sliding gates up to 400 kg and with a leaf up to 6 m.



Motor with integrated control unit and absolute encoder, can be installed inside a small, suitably drilled post.

The **very small size** allows the motor to be housed in even very slim posts, with a minimum internal size of 140x140 mm.

**Simple:** thanks to the BlueBUS system allowing connections with just two wires between the control unit and up to 7 pairs of photocells and control, safety and signalling devices.

**Master/slave selection:** also automatically synchronises 2 motors, allowing automation of sliding gates with two opposing leaves.

**Smart:** thanks to obstacle detection and automatic programming of operating times. Self-diagnostics with indications via the flashing light.

**Safe:** adjustable acceleration and deceleration at the start and end of each manoeuvre.

**Simple and precise limit switch regulation:** integrated absolute limit switch, rapid learning in a single movement with motor released.

**Practical:** control unit and PSS124 buffer batteries (optional) connected by practical guided plug-in connector.

**Flexible:** the release can be provided on both sides of the post and/or outside (with KIO and KA1 accessories). Easy installation even on existing posts.

BlueBus

BiDi

Programmable via App

24V

Yubii

With Pro-View or Bidi-WiFi &amp; MyNice Pro App.

Solemyo

Opera



Code	Description	Pcs./Pallet
<b>NKSL400</b>	Non-reversible, 24 VDC, with integrated control unit and absolute encoder, for integrated installation in post	40

**COMMON ACCESSORIES**

Code	Description	Pcs. Pack
<b>SPNKA3R10</b>	Control units	1
<b>PSS124</b>	24 V battery with integrated battery charger	1
<b>ROA6</b>	Slotted rack, M4 25x20x1000 mm, nylon with metal insert. For gates up to 500 kg	10
<b>ROA66</b>	Slotted nylon rack M4 25x20x1000 mm with metal core and six clear fastening points. For gates weighing up to 800 kg	10
<b>ROA7</b>	Galvanised rack, M4 22x22x1000 mm	10
<b>ROA8</b>	Galvanised rack, M4 30x8x1000 mm, with screws and spacers	10
<b>KIO</b>	Key switch for low-voltage contacts, with release mechanism for metal cable	1
<b>KA1</b>	Kit with 6 m metal cable for KIO	1
<b>SYKCE30</b>	Solar power supply kit consisting of SYP30 photovoltaic panel, PSY24 battery box with charging control circuit and SYA1 charger	1
<b>TS</b>	Sign	1

Find out more on page → 118.

**TECHNICAL SPECIFICATIONS**

Code	<b>NKSL400</b>
<b>ELECTRICAL SPECIFICATIONS</b>	
Power supply (VAC 50/60 Hz)	230
Draw (A)	1,1
Power (W)	250
<b>PERFORMANCE DATA</b>	
Speed (m/s)	0,34
Force (N)	400
Working cycle (cycles/hour)	35
<b>DIMENSIONAL AND GENERAL DATA</b>	
Protection class (IP)	44*
Operating temperature (°C Min/Max)	-20 ÷ +50
Dimensions (mm)	131x135x405 h
Weight (kg)	6,5

\* The protection class of the installed automation is determined by the "motor + post" composition.

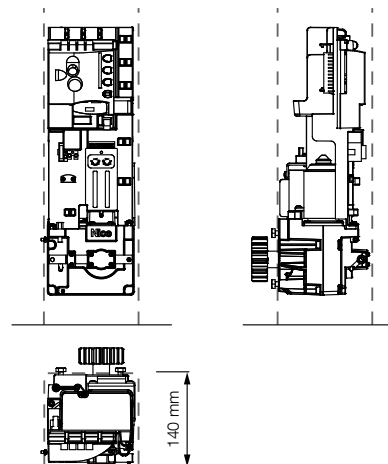
**DIMENSIONS****COMPATIBILITY WITH CONTROL SYSTEMS AND ACCESSORIES**

**NKSL400**

**Control unit/Receiver**

**Integrated\***

- **OXIBD / OXILR**

**Transmitter**

- **ERA INTI** - 2 channels, 433.92 MHz, different colours
- **ERA ONE / MYGO** - 2, 4 or 8 channels, 433.92 MHz
- **MYGOBD / ERA ONE LR**

- **DOMI**

**Photocells**

- **EPS** - Slim / **EPM** - Medium / **EPL** - Large
- **EPSB** - Slim, BlueBUS / **EPMB** - Medium, BlueBUS / **EPLB** - Large, BlueBUS
- **EPMOR** - Medium, reflective
- **EPMORB** - Medium, BlueBUS, reflective
- **EPMOW** - Medium, wireless self-synchronised
- **F210** - Synchronised, adjustable / **FT210** - For sensitive edges
- **F210B** - BlueBUS
- **FT210B** - For sensitive edges, BlueBUS

**Flashing light****ELAC**

- **ELDC**
- **WLT** - Multifunction LED light

\* Radio receiver not compatible with the O-box functions of the Opera system.

Nice

# Slight

For sliding gates up to 400 kg with leaves up to 6 m.



Also available in a KIT

LED courtesy  
or flashing  
light



Motor with integrated control unit and absolute encoder.

**Innovative ultra-compact design:** the vertical configuration of the motor makes it easy to install even in narrow openings.

**Simple:** thanks to the BlueBUS system allowing connections with just two wires between the control unit and up to 7 pairs of photocells and control, safety and signalling devices.

**Integrated LED light:** programmable as either a flashing or courtesy light, warns of gate movement during opening and closing.

**Master/slave selection:** also automatically synchronises 2 motors, allowing automation of sliding gates with two opposing leaves.

**Smart:** thanks to obstacle detection and automatic programming of operating times. Self-diagnostics with indications via the flashing light.

**Safe:** adjustable acceleration and deceleration at the start and end of each manoeuvre.

**Integrated absolute limit switch.**

- simple and precise regulation thanks to the rapid learning in a single movement with the motor released;
- no bracket or accessory to be installed on the rack;
- particularly suitable for snowy areas.

**Practical:** control unit and PSS124 buffer batteries (optional) connected by practical guided plug-in connector.

BlueBus

BiDi

Programmable via  
App

24V

Yubii

With Pro-View or  
Bidi-WiFi & MyNice  
Pro App.

Solemyo

Opera



Code	Description	Pcs./Pallet
<b>SLH400</b>	Non-reversible, 24 VDC, with integrated control unit and absolute encoder. Integrated LED light	40
<b>SLH400BDKCE</b>	Kit for automating sliding gates up to 400 kg, non-reversible, 24 VDC, with integrated control unit and absolute encoder, integrated LED light, with bidirectional technology	18

**The SLH400BDKCE kit contains:**

Code	Description	Quantity
<b>SLH400</b>	Non-reversible electromechanical gearmotor, with control unit and OXIBD plug-in bidirectional radio receiver included, absolute encoder and integrated LED light	1
<b>MYGO4</b>	4-channel 433.92 MHz transmitter	2
<b>EPMB</b>	Pair of surface mounted photocells with provision for connection via Nice BlueBUS	1
<b>ELDC</b>	Flashing LED light with integrated antenna	1
<b>TS</b>	Sign	1

**N.B.** The contents of the pack may vary: always consult the dealer.

**COMMON ACCESSORIES**

Code	Description	Pcs. Pack
<b>SPNKA3R10</b>	Control units	1
<b>PSS124</b>	24 V battery with integrated battery charger	1
<b>ROA6</b>	Slotted rack, M4 25x20x1000 mm, nylon with metal insert. For gates up to 500 kg	10
<b>ROA66</b>	Slotted nylon rack M4 25x20x1000 mm with metal core and six clear fastening points. For gates weighing up to 800 kg	10
<b>ROA7</b>	Galvanised rack, M4 22x22x1000 mm	10
<b>ROA8</b>	Galvanised rack, M4 30x8x1000 mm, with screws and spacers	10
<b>SYKCE30</b>	Solar power supply kit consisting of SYP30 photovoltaic panel, PSY24 battery box with charging control circuit and SYA1 charger	1
<b>TS</b>	Sign	1

Find out more on page → 118.

**TECHNICAL SPECIFICATIONS**

Code	SLH400
<b>ELECTRICAL SPECIFICATIONS</b>	
Power supply (VAC 50/60 Hz)	230
Draw (A)	1,1
Power (W)	250
<b>PERFORMANCE DATA</b>	
Speed (m/s)	0,34
Force (N)	400
Working cycle (cycles/hour)	35
<b>DIMENSIONAL AND GENERAL DATA</b>	
Protection class (IP)	44
Operating temperature (°C Min/Max)	-20 ÷ +50
Dimensions (mm)	191x198x405 h
Weight (kg)	6,5

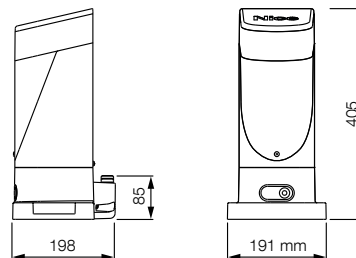
**DIMENSIONS**

**COMPATIBILITY WITH CONTROL SYSTEMS AND ACCESSORIES**
**SLH400**
**Control unit/Receiver**
**Integrated\***

- **OXIBD / OXILR**

**Transmitter**

- **ERA INTI** - 2 channels, 433.92 MHz, different colours
- **ERA ONE / MYGO** - 2, 4 or 8 channels, 433.92 MHz
- **MYGOBD / ERA ONE LR**
- **DOMi**

**Photocells**

**EPS** - Slim / **EPM** - Medium / **EPL** - Large

- **EPSB** - Slim, BlueBUS / **EPMB** - Medium, BlueBUS / **EPLB** - Large, BlueBUS
- **EPMOR** - Medium, reflective
- **EPMORB** - Medium, BlueBUS, reflective
- **EPMOW** - Medium, wireless self-synchronised
- **F210** - Synchronised, adjustable / **FT210** - For sensitive edges
- **F210B** - BlueBUS
- **FT210B** - For sensitive edges, BlueBUS

**Flashing light**
**ELAC**

- **ELDC**
- **WLT** - Multifunction LED light

\* Radio receiver not compatible with the O-box functions of the Opera system.

Nice

# Robus 400/600/800 New

For sliding gates weighing up to 400 kg (RBS400), 600 kg (RBS600) and 800 kg (RBS800).



Also available in a KIT



Eye Check



NICE GREEN  
INNOVATION

EPD®

S-P-11924

BlueBus

24V

BiDi

Yubii

Solemyo

Opera

Programmable via  
App

With Pro-View or  
Bidi-WiFi & MyNice  
Pro App.



**Non-reversible, 24 VDC, magnetic limit switch, control unit with built-in radio receiver,** compatible with optional buffer battery (PSS124).

**Efficient and safe:** functional mechanical design and high-performance materials.

**Standby power consumption 0.4W.**

**Safe and easy-to-use release lever; magnetic limit switch,** easy to install and allows for shorter rack length.

**Easy to programme**

thanks to the MyNice Pro app, connecting the control unit to the Pro-View or BiDi-WiFi.

**Easy to install:**

- control unit with integrated receiver in raised position;
- maximum freedom in horizontal and vertical base adjustment.
- BlueBUS connector allows connections with just two wires between the control unit and up to 7 pairs of photocells and control, safety and signalling devices;
- expandable control unit with accessory modules to increase the number of inputs or outputs;
- fastening backwardcompatible with previous Nice models.

**Smart:**

- self-teaching work times;
- control slowdown, speed and force;
- self-diagnosis with status of automation and accessories signalled via the new **Eye Check system.**

**Always connected** even remotely, thanks to the BIDI-WIFI or BIDI-ZWAVE module.

Code	Description	Pcs./Pallet
<b>RBS400</b>	Non-reversible electromechanical gearmotor, 24 VDC, with control unit and integrated receiver, magnetic limit switch, for gates weighing up to 400 kg	30
<b>RBS400BDKCE</b>	Kit for automating a sliding gate up to 400 kg. The kit contains RBS400, 2 x MYGO4, 1 x EPMB, 1 x ELDC, 1 x TS.	18
<b>RBS400BDKLT</b>	Kit for automating a sliding gate up to 400 kg. The kit contains RBS400, 2 x MYGO4, 1 x TS.	30
<b>RBS600</b>	Non-reversible electromechanical gearmotor, 24 VDC, with control unit and integrated receiver, magnetic limit switch, for gates weighing up to 600 kg	30
<b>RBS600BDKCE</b>	Kit for automating a sliding gate up to 600 kg. The kit contains RBS600, 2 x MYGO4, 1 x EPMB, 1 x ELDC, 1 x TS.	18
<b>RBS600BDKLT</b>	Kit for automating a sliding gate up to 600 kg. The kit contains RBS600, 2 x MYGO4, 1 x TS.	30
<b>RBS800</b>	Non-reversible electromechanical gearmotor, 24 VDC, with control unit and integrated receiver, magnetic limit switch, for gates weighing up to 800 kg	30
<b>RBS800BDKCE</b>	Kit for automating a sliding gate up to 800 kg. The kit contains RBS800, 2 x MYGO4, 1 x EPMB, 1 x ELDC, 1 x TS	18
<b>RBS800BDKLT</b>	Kit for automating a sliding gate up to 800 kg. The kit contains RBS800, 2 x MYGO4, 1 x TS	30

**N.B.** The contents of the pack may vary: always consult the dealer.

**The RBS400BDKCE kit contains:**

Code	Description	Quantity
<b>RBS400</b>	Non-reversible electromechanical gearmotor, 24 VDC, with control unit and integrated receiver, for gates weighing up to 400 kg	1
<b>MYGO4</b>	4-channel 433.92 MHz transmitter	2
<b>EPMB</b>	Pair of surface-mounted photocells compatible with BlueBUS connection	1
<b>ELDC</b>	Flashing LED light with integrated antenna	1
<b>TS</b>	Safety sign	1

**The RBS400BDKLT kit contains:**

Code	Description	Quantity
<b>RBS400</b>	Non-reversible electromechanical gearmotor, 24 VDC, with control unit and integrated receiver, for gates weighing up to 400 kg	1
<b>MYGO4</b>	4-channel 433.92 MHz transmitter	2
<b>TS</b>	Safety sign	1

**The RBS600BDKCE kit contains:**

Code	Description	Quantity
<b>RBS600</b>	Non-reversible electromechanical gearmotor, 24 VDC, with control unit and integrated receiver, for gates weighing up to 600 kg	1
<b>MYGO4</b>	4-channel 433.92 MHz transmitter	2
<b>EPMB</b>	Pair of surface-mounted photocells compatible with BlueBUS connection	1
<b>ELDC</b>	Flashing LED light with integrated antenna	1
<b>TS</b>	Safety sign	1

**The RBS600BDKLT kit contains:**

Code	Description	Quantity
<b>RBS600</b>	Non-reversible electromechanical gearmotor, 24 VDC, with control unit and integrated receiver, for gates weighing up to 600 kg	1
<b>MYGO4</b>	4-channel 433.92 MHz transmitter	2
<b>TS</b>	Safety sign	1

**The RBS800BDKCE kit contains:**

Code	Description	Quantity
<b>RBS800</b>	Non-reversible electromechanical gearmotor, 24 VDC, with control unit and integrated receiver, for gates weighing up to 800 kg	1
<b>MYGO4</b>	4-channel 433.92 MHz transmitter	2
<b>EPMB</b>	Pair of surface-mounted photocells compatible with BlueBUS connection	1
<b>ELDC</b>	Flashing LED light with integrated antenna	1
<b>TS</b>	Safety sign	1

**The RBS800BDKLT kit contains:**

Code	Description	Quantity
<b>RBS800</b>	Non-reversible electromechanical gearmotor, 24 VDC, with control unit and integrated receiver, for gates weighing up to 800 kg	1
<b>MYGO4</b>	4-channel 433.92 MHz transmitter	2
<b>TS</b>	Safety sign	1

N.B. Pack contents may vary: always consult the dealer.

**COMMON ACCESSORIES**

Code	Description	Pcs	Pack
<b>SPMCU1</b>	Spare control unit for RBS400, RBS600, and RBS800	1	
<b>MLAE21</b>	Plug-in expansion board 1 Output 2 Input	1	
<b>MLAE22</b>	Plug-in expansion board 2 Output (1 230V Relay) 2 Input	1	
<b>MLAE44</b>	Plug-in expansion board 4 Output 4 Input	1	
<b>ROA6</b>	Slotted rack, M4 25x20x1000 mm, nylon with metal insert. For gates up to 500 kg	10	
<b>ROA66</b>	Slotted nylon rack M4 25x20x1000 mm with metal core, six fastening points. For gates weighing up to 800 kg	10	
<b>ROA7</b>	Galvanised rack, M4 22x22x1000 mm	10	
<b>ROA8</b>	Galvanised rack M4 30x8x1000 mm, with screws and spacers.	10	
<b>PSS124</b>	24 V battery with integrated battery charger	1	
<b>SYKCE30</b>	Solar power supply kit consisting of SYP30 photovoltaic panel, PSY24 battery box with charging control circuit and SYA1 charger	1	

Code	RBS400	RBS600	RBS800
Power supply (VAC 50/60 Hz)	230	230	230
Draw (A)	1,1	2,1	1,1
Power (W)	250	450	230
Power in standby (W)	0.4	0.4	0.4
Speed (m/s)	0,34	0,34	0,30
Force (N)	510	700	750
Working cycle (cycles/hour) 4 m leaf	35	40	35
Protection class (IP)		44	
Operating temperature (°C Min/Max)		-20 ÷ +55	
Dimensions (mm)		340x220x303 h	
Weight (kg)	11	11	

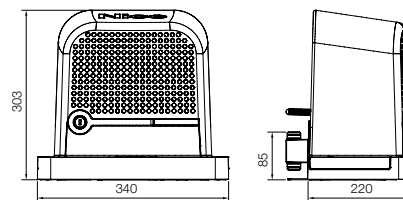
**DIMENSIONS****COMPATIBILITY WITH CONTROL SYSTEMS AND ACCESSORIES**

RBS400  
RBS600

**Control unit/Receiver**

- • **Integrated\***
- • **OXIBD / OXILR**

**Transmitter**

- • **ERA INTI** - 2 channels, 433.92 MHz, different colours
- • **ERA ONE / MYGO** - 2, 4 or 8 channels, 433.92 MHz
- • **MYGOBD / ERA ONE LR**
- • **DOMI**

**Photocells**

- • **EPSB** - Slim, BlueBUS / **EPMB** - Medium, BlueBUS / **EPLB** - Large, BlueBUS
- • **EPMOR** - Medium, reflective
- • **EPMORB** - Medium, BlueBUS, reflective
- • **EPMOW** - Medium, wireless self-synchronised
- • **F210B** - BlueBUS
- • **FT210B** - For sensitive edges, BlueBUS

**Flashing light**

- • **ELDC**
- • **WLT** - Multifunction LED light

\* Radio receiver not compatible with the O-box functions of the Opera system.

Nice

# Robus 1000

For sliding gates up to 1000 kg (RB1000).



Also available in a KIT



Compartment for control unit protected by removable box and buffer batteries

Release with aluminium handle for easy opening

BlueBus

BiDi

Programmable via App

24V

Yubii

With Pro-View or Bidi-WiFi & MyNice Pro App.

Solemyo

Opera



Versions with electromechanical limit switch (RB1000) and inductive limit switch (RB1000P).

**Simple:** thanks to the BlueBUS system allowing connections with just two wires between the control unit and up to 7 pairs of photocells and control, safety and signalling devices.

**Practical:** control unit and PSS124 buffer batteries (optional) connected by practical guided plug-in connector.

**Advanced:** RB1000 are fitted with a temperature sensor that adapts the motor force to the climatic conditions while at the same time adjusting the thermal protection. A master/slave selection also automatically synchronises 2 motors, allowing automation of sliding gates with two opposing leaves.

**Smart:** thanks to obstacle detection and automatic programming of operating times. Self-diagnostics with indications via the flashing light. 8 programming levels.

**Safe:** adjustable acceleration and deceleration at the start and end of each manoeuvre.

**Sturdy:** release with aluminium handle for easy opening.

**Quiet:** gearmotor on bearings.

Code	Description	Pcs./Pallet
<b>RB1000</b>	Non-reversible, 24 VDC, with integrated control unit, electromechanical limit switch, for gates up to 1000 kg	15
<b>RB1000P</b>	Non-reversible, 24 VDC, with integrated control unit, inductive limit switch, for gates up to 1000 kg	15
<b>RB1000BDKCE</b>	Kit for automating sliding gates up to 1000 kg. 24 VDC, integrated control unit, with bidirectional technology. The kit contains RB1000, 2 x MYGO4, 1 x EPMB, 1 x ELDC, 1 x TS.	14

**The RB1000BDKCE kit contains:**

Code	Description	Quantity
<b>RB1000</b>	Non-reversible electromechanical gearmotor, with built-in control unit and OXIBD plug-in bidirectional radio receiver for connection via Nice BlueBUS	1
<b>MYGO4</b>	4-channel 433.92 MHz transmitter	2
<b>EPMB</b>	Pair of surface mounted photocells with provision for connection via Nice BlueBUS	1
<b>ELDC</b>	Flashing LED light with integrated antenna	1
<b>TS</b>	Sign	1

N.B. The contents of the pack may vary: always consult the dealer.

**COMMON ACCESSORIES**

Code	Description	Pcs. Pack
<b>SPRBA3R10</b>	Spare control unit, for RB400, RB600/600P, RB1000/1000P and RUN1500/1500P	1
<b>PSS124</b>	24 V battery with integrated battery charger	1
<b>RBA1</b>	Inductive limit switch	1
<b>ROA6</b>	Slotted rack, M4 25x20x1000 mm, nylon with metal insert. For gates up to 500 kg	10
<b>ROA66</b>	Slotted nylon rack M4 25x20x1000 mm with metal core and six clear fastening points. For gates weighing up to 800 kg	10
<b>ROA7</b>	Galvanised rack, M4 22x22x1000 mm	10
<b>ROA8</b>	Galvanised rack, M4 30x8x1000 mm, with screws and spacers	10
<b>SYKCE30</b>	Solar power supply kit consisting of SYP30 photovoltaic panel, PSY24 battery box with charging control circuit and SYA1 charger	1
<b>TS</b>	Sign	1

Find out more on page → 118.

**TECHNICAL SPECIFICATIONS**

Code	RB1000/1000P
<b>ELECTRICAL SPECIFICATIONS</b>	
Power supply (VAC 50/60 Hz)	230
Draw (A)	2,3
Power (W)	450
<b>PERFORMANCE DATA</b>	
Speed (m/s)	0,28
Force (N)	900
Working cycle (cycles/hour)	50
<b>DIMENSIONAL AND GENERAL DATA</b>	
Protection class (IP)	44
Operating temperature (°C Min/Max)	-20 ÷ +50
Dimensions (mm)	330x210x303 h
Weight (kg)	13

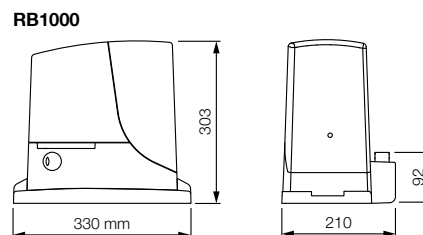
**DIMENSIONS**

**COMPATIBILITY WITH CONTROL SYSTEMS AND ACCESSORIES**

RB1000/1000P
<b>Control unit/Receiver</b>
<b>Integrated*</b>
• OXIBD / OXILR
<b>Transmitter</b>
• ERA INTI - 2 channels, 433.92 MHz, different colours
• ERA ONE / MYGO - 2, 4 or 8 channels, 433.92 MHz
• MYGOBD / ERA ONE LR
• DOMI
<b>Photocells</b>
EPS - Slim / EPM - Medium / EPL - Large
• EPSB - Slim, BlueBUS / EPMB - Medium, BlueBUS / EPLB - Large, BlueBUS
• EPMOR - Medium, reflective
• EPMORB - Medium, BlueBUS, reflective
• EPMOW - Medium, wireless self-synchronised
F210 - Synchronised, adjustable / FT210 - For sensitive edges
• F210B - BlueBUS
• FT210B - For sensitive edges, BlueBUS
<b>Flashing light</b>
ELAC
• ELDC
• WLT - Multifunction LED light

\* Radio receiver not compatible with the O-box functions of the Opera system.

Nice

# Road

For sliding gates up to 400 kg.



Available in a KIT



**Practical:** built-in control unit, removable via practical guided plug-in connector, integrated radio receiver: can store up to 100 codes!

**Advanced:** Decelerations can be managed directly from the control unit and gate movement speed and force can be adjusted.

**Smart:** thanks to obstacle detection and automatic programming of operating times. Self-diagnostics with indications via the flashing light.

**Safe and reliable:** control unit and PSS124 buffer batteries (optional) housed in Road, practical plug-in connections.

24V

Opera

Programmable via App

With Pro-View or Bidi-WiFi & MyNice Pro App.



Code	Description	Pcs./Pallet
<b>RDKCE</b>	Kit for sliding gates up to 400 kg and with leaves up to 6 m, 24 VDC, with built-in receiver and control unit	18



#### The RDKCE kit contains:

Code	Description	Quantity
<b>RD400</b>	Non-reversible electromechanical gearmotor, 24 VDC, with built-in receiver and control unit, provision for PSS124 buffer battery (optional)	1
<b>INTI2</b>	Transmitter, 433.92 MHz, 2 channels	2
<b>EPM</b>	Pair of surface mounted photocells	1
<b>ELDC</b>	Flashing LED light with integrated antenna	1
<b>TS</b>	Sign	1

**N.B.** The contents of the pack may vary: always consult the dealer.

#### COMMON ACCESSORIES

Code	Description	Pcs. Pack
<b>SPRBA4R10</b>	Spare control unit for RDKCE	1
<b>PSS124</b>	24 V battery with integrated battery charger	1
<b>CM-B</b>	Release ratchet with two metal keys	1
<b>ROA6</b>	Slotted rack, M4 25x20x1000 mm, nylon with metal insert. For gates up to 500 kg	10
<b>ROA66</b>	Slotted nylon rack M4 25x20x1000 mm with metal core and six clear fastening points. For gates weighing up to 800 kg	10
<b>ROA7</b>	Galvanised rack, M4 22x22x1000 mm	10
<b>ROA8</b>	Galvanised rack, M4 30x8x1000 mm, with screws and spacers	10

Find out more on page → 118.

#### TECHNICAL SPECIFICATIONS

Code	<b>RD400</b>
<b>ELECTRICAL SPECIFICATIONS</b>	
Power supply (VAC 50/60 Hz)	230
Draw (A)	1,1
Power (W)	210
<b>PERFORMANCE DATA</b>	
Speed (m/s)	0,25
Force (N)	400
Working cycle (cycles/hour)	20
<b>DIMENSIONAL AND GENERAL DATA</b>	
Protection class (IP)	44
Operating temperature (°C Min/Max)	-20 ÷ +55
Dimensions (mm)	330x195x277 h
Weight (kg)	8

#### DIMENSIONS

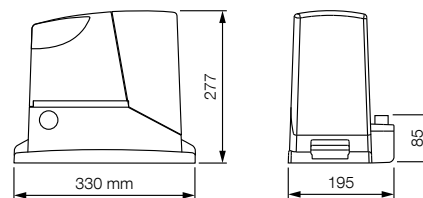

#### COMPATIBILITY WITH CONTROL SYSTEMS AND ACCESSORIES

##### RD400

##### Control unit/Receiver

- **Integrated\***

##### OXIBD / OXILR

##### Transmitter

- **ERA INTI** - 2 channels, 433.92 MHz, different colours
- **ERA ONE / MYGO** - 2, 4 or 8 channels, 433.92 MHz

##### MYGOBD / ERA ONE LR

- **DOMi**

##### Photocells

- **EPS** - Slim / **EPM** - Medium / **EPL** - Large
- **EPSB** - Slim, BlueBUS / **EPMB** - Medium, BlueBUS / **EPLB** - Large, BlueBUS
- **EPMOR** - Medium, reflective
- **EPMORB** - Medium, BlueBUS, reflective
- **EPMOW** - Medium, wireless self-synchronised

- **F210** - Synchronised, adjustable / **FT210** - For sensitive edges

##### F210B - BlueBUS

##### FT210B - For sensitive edges, BlueBUS

##### Flashing light

##### ELAC

- **ELDC**
- **WLT** - Multifunction LED light

\* Radio receiver not compatible with the O-box functions of the Opera system.

Nice

# Robo 600

For sliding gates up to 600 kg.



Available in a KIT



Non-reversible, 230 VAC, electromechanical limit switch, control unit with integrated radio receiver.

**Efficient and safe:** functional mechanical design and high-performance materials. Safe and easy-to-use release lever.

**Easy to programme** thanks to the MyNice Pro app, connecting the control unit to the Pro-View or BiDi-WiFi, making all control unit programming easy and automatic.

**Easy to install:** thanks to compatibility with previous Nice models and horizontal and vertical adjustment systems.

**Always connected** even remotely, thanks to the BIDI-WIFI or BIDI-ZWAVE module

230V

Opera

**Programmable via App**

With Pro-View or Bidi-WiFi & MyNice Pro App.



Code	Description	Pcs./Pallet
<b>RO600</b>	Non-reversible electromechanical gearmotor, 230 VAC, with control unit and integrated receiver, for sliding gates weighing up to 600 kg	30
<b>RO600KCE</b>	Kit for automating sliding gates up to 600 kg, 230 VAC, integrated control unit, integrated radio receiver. The kit includes: RO600, 2 x INTI2, 1 x EPM, 1 x ELAC	18
<b>RO600KLT</b>	EasyKit for automating sliding gates up to 600 kg, 230 VAC, integrated control unit, integrated radio receiver. The kit includes: RO600, 2 x INTI2	30

N.B. Pack contents may vary: always consult the dealer



#### The RO600KCE kit contains:

Code	Description	Quantity
<b>RO600</b>	Non-reversible electromechanical gearmotor, 230 VAC, with control unit and integrated receiver, for sliding gates weighing up to 600 kg	1
<b>INTI2</b>	Transmitter, 433.92 MHz, 2 channels	2
<b>EPM</b>	Pair of surface mounted photocells	1
<b>ELAC</b>	Flashing LED light with integrated antenna	1



#### The RO600KLT kit contains:

Code	Description	Quantity
<b>RO600</b>	Non-reversible electromechanical gearmotor, 230 VAC, with control unit and integrated receiver, for sliding gates weighing up to 600 kg	1
<b>INTI2</b>	Transmitter, 433.92 MHz, 2 channels	2

#### COMMON ACCESSORIES

Code	Description	Pcs. Pack
<b>SPROA41R30</b>	Spare control unit for RO600	1
<b>ROA6</b>	Slotted nylon rack M4 25x20x1000 mm with metal core. For gates weighing up to 500 kg	1
<b>ROA7</b>	Galvanised rack, M4 22x22x1000 mm	1
<b>ROA8</b>	Galvanised rack M4 30x8x1000 mm, with screws and spacers.	1
<b>TS</b>	Sign	1

Find out more on page → 118.

#### TECHNICAL SPECIFICATIONS

Code	RO600
<b>ELECTRICAL SPECIFICATIONS</b>	
Power supply (VAC 50/60 Hz)	230
Power (W)	300
Power in standby (W)	0.45
<b>PERFORMANCE DATA</b>	
Speed (m/s)	0,18
Force (N)	600
Working cycle (cycles/hour)	20
<b>DIMENSIONAL AND GENERAL DATA</b>	
Protection class (IP)	44
Operating temperature (°C Min/Max)	-20 ÷ +55
Dimensions (mm)	340x220x303 h
Weight (kg)	11

#### DIMENSIONS

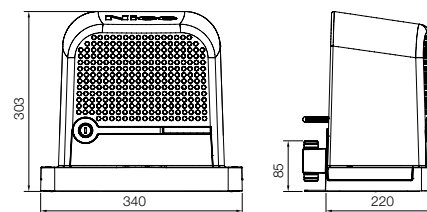

#### COMPATIBILITY WITH CONTROL SYSTEMS AND ACCESSORIES

ROBO

##### Control unit/Receiver

- Integrated\*

##### OXIBD / OXILR

##### Transmitter

- ERA INTI - 2 channels, 433.92 MHz, different colours
- ERA ONE / MYGO - 2, 4 or 8 channels, 433.92 MHz

##### MYGOBD / ERA ONE LR

- DOMi

##### Photocells

- EPS - Slim / EPM - Medium / EPL - Large
- EPSB - Slim, BlueBUS / EPMB - Medium, BlueBUS / EPLB - Large, BlueBUS
- EPMOR - Medium, reflective
- EPMORB - Medium, BlueBUS, reflective
- EPMOW - Medium, wireless self-synchronised

- F210 - Synchronised, adjustable / FT210 - For sensitive edges

##### F210B - BlueBUS

##### Flashing light

- ELAC

##### ELDC

- WLT - Multifunction LED light

\* Radio receiver not compatible with the O-box functions of the Opera system.

Nice

# Robo1000/1500 New

For sliding gates up to 1000 kg (RO1000),  
1500 kg (RO1500).



Also available in a KIT



Non-reversible, 230 VAC, electromechanical limit switch, control unit with built-in radio receiver.

**Robust and safe:** functional mechanical design and high-performance materials.  
Safe and easy-to-use release lever.

**Easy to programme** thanks to the MyNice Pro app, connecting the control unit to the Pro-View or BiDi-WiFi, making all control unit programming easy and automatic.

**Easy to install:** thanks to compatibility with previous Nice models and horizontal and vertical adjustment systems.

**Always connected** even remotely, thanks to the BIDI-WIFI or BIDI-ZWAVE module.

230V

Opera



**Programmable via App**

With Pro-View or Bidi-WiFi & MyNice Pro App.

Code	Description	Pcs./Pallet
<b>RO1000</b>	Non-reversible electromechanical gearmotor, 230 VAC, with integrated control unit and integrated receiver, for gates up to 1000 kg	18
<b>RO1000KCE</b>	Kit for automating a sliding gate weighing up to 1000 kg, 230 VAC, with built-in control unit and integrated receiver. The kit includes: RO1000, 2 x INTI2, 1 x EPM, 1 x ELAC	18
<b>RO1000KLT</b>	Kit for automating a sliding gate weighing up to 1000 kg, 230 VAC, with built-in control unit and integrated receiver. The kit includes: RO1000, 2 x INTI2	18
<b>RO1500</b>	Non-reversible electromechanical gearmotor, 230 VAC, with built-in control unit and integrated receiver, for gates up to 1500 kg	18
<b>RO1500KCE</b>	Kit for automating a sliding gate weighing up to 1500 kg, 230 VAC, with built-in control unit and integrated receiver. The kit includes: RO1500, 2 x INTI2, 1 x EPM, 1 x ELAC	18
<b>RO1500KLT</b>	Kit for automating a sliding gate up to 1500 kg, 230 VAC, with built-in control unit and integrated receiver. The kit contains RO1500, 2 x INTI2	18

N.B. Pack contents may vary: always consult the dealer.



#### The RO1000KCE kit contains:

Code	Description	Quantity
<b>RO1000</b>	Non-reversible electromechanical gearmotor, 230 VAC, with integrated control unit and integrated receiver, for gates up to 1000 kg	1
<b>INTI2</b>	Transmitter, 433.92 MHz, 2 channels	2
<b>EPMB</b>	Pair of wall-mounted photocells compatible with BlueBUS connection	1
<b>ELDC</b>	Flashing LED light with integrated antenna	1
<b>TS</b>	Sign	1



#### The RO1000KLT kit contains:

Code	Description	Quantity
<b>RO1000</b>	Non-reversible electromechanical gearmotor, 230 VAC, with integrated control unit and integrated receiver, for gates up to 1000 kg	1
<b>INTI2</b>	Transmitter, 433.92 MHz, 2 channels	2
<b>TS</b>	Sign	1



#### The RO1500KCE kit contains:

Code	Description	Quantity
<b>RO1500</b>	Non-reversible electromechanical gearmotor, 230 VAC, with built-in control unit and integrated receiver, for gates up to 1500 kg	1
<b>INTI2</b>	Transmitter, 433.92 MHz, 2 channels	2
<b>EPMB</b>	Pair of wall-mounted photocells compatible with BlueBUS connection	1
<b>ELDC</b>	Flashing LED light with built-in antenna	1
<b>TS</b>	Sign	1



#### Il kit RO1500KLT contiene:

Code	Description	Quantity
<b>RO1500</b>	Non-reversible electromechanical gearmotor, 230 VAC, with built-in control unit and integrated receiver, for gates up to 1500 kg	1
<b>INTI2</b>	Transmitter, 433.92 MHz, 2 channels	2
<b>TS</b>	Sign	1

N.B. Pack contents may vary: always consult the dealer.

## COMMON ACCESSORIES

Code	Description	Pcs. Pack
<b>SPROA42</b>	Spare control unit for RO1000	1
<b>SPROA43</b>	Spare control unit for RO1500	1
<b>ROA7</b>	M4 rack 22x22x1000 mm, galvanized	1
<b>ROA8</b>	M4 rack 30x8x1000 mm, galvanized, complete with screws and spacers	1
<b>TS</b>	Sign	1

Find out more on page → 118.

## TECHNICAL SPECIFICATIONS

Code	RO1000	RO1500
Power supply (VAC 50/60 Hz)	230	230
Draw (A)	1,6	1,7
Power (W)	350	350
Power in standby (W)	<0.45	<0.45
Speed (m/s)	0,18	0,16
Force (N)	680	780
Working cycle (cycles/hour)	16	22
Protection class (IP)	44	
Operating temperature (°C Min/Max)	-20 ÷ +50	
Dimensions (mm)	363x238x364 h	
Weight (kg)	11,5	13

## DIMENSIONS

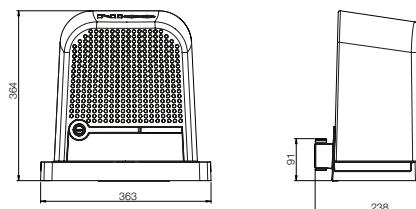

## COMPATIBILITY WITH CONTROL SYSTEMS AND ACCESSORIES

RO1000  
RO1500

### Control unit/Receiver

- **Integrated\***

### OXIBD / OXILR

#### Transmitter

- **ERA INTI** - 2 channels, 433.92 MHz, different colours
- **ERA ONE / MYGO** - 2, 4 or 8 channels, 433.92 MHz

### MYGOBD / ERA ONE LR

- **DOMI**

### Photocells

- **EPS** - Slim / **EPM** - Medium / **EPL** - Large
- **EPSB** - Slim, BlueBus / **EPMB** - Medium, BlueBus / **EPLB** - Large, BlueBus

- **EP MOR** - Medium, reflective

### EP MORB - Medium, BlueBUS, reflective

### EP MOW - Medium, wireless self-synchronised

- **F210** - Synchronised, adjustable / **FT210** - For sensitive edges

### F210B - BlueBus

### Flashing light

- **ELAC**

### ELDC

### WLT - Multifunction LED light

\* Radio receiver not compatible with the O-box functions of the Opera system.

Nice

# Run 1500

For sliding gates up to 1500 kg.



Compartment for control unit  
protected by pull-out box

Base and release  
in epoxy-painted  
die-cast aluminium

Versions with electromechanical limit switch (RUN1500) and inductive limit switch (RUN1500P).

**Simple:** thanks to the BlueBUS system allowing connections with just two wires between the control unit and up to 7 pairs of photocells and control, safety and signalling devices.

**Practical:** control unit and PSS124 buffer batteries (optional) housed in Run, practical guided plug-in connector.

**Advanced:** the temperature sensor adapts the motor force to the climatic conditions while at the same time adjusting the thermal protection; a master/slave selection automatically synchronises 2 motors, allowing automation of sliding gates with two opposing leaves.

**Smart:** thanks to obstacle detection and automatic programming of operating times. Self-diagnostics with indications via the flashing light. 8 programming levels.

**Safe:** adjustable acceleration and deceleration at the start and end of each manoeuvre.

**Sturdy:** release with aluminium handle for easy opening.

**Quiet:** gearmotor on bearings.

BlueBus

BiDi

Programmable via  
App

24V

Yubii

With Pro-View  
or BiDi-WiFi Ext &  
MyNice Pro  
App.

Solemyo

Opera



Code	Description	Pcs./Pallet
<b>RUN1500</b>	Non-reversible, 24 VDC, with integrated control unit, electromechanical limit switch, for gates up to 1500 kg	18
<b>RUN1500P</b>	Non-reversible, 24 VDC, with integrated control unit, inductive limit switch, for gates up to 1500 kg	18

#### COMMON ACCESSORIES

Code	Description	Pcs. Pack
<b>SPRBA3R10</b>	Spare control unit, for RB400, RB600/600P, RB1000/1000P and RUN1500/1500P	1
<b>PSS124</b>	24 V battery with integrated battery charger	1
<b>RBA1</b>	Inductive limit switch	1
<b>ROA7</b>	Galvanised rack, M4 22x22x1000 mm	10
<b>ROA8</b>	Galvanised rack, M4 30x8x1000 mm, with screws and spacers	10
<b>ROA81</b>	Galvanised rack M6 30x30x1000 mm, weld-on, for use with RUA12 crown	10
<b>RUA12</b>	12-tooth crown, module 6, for use with ROA81 rack. Run is supplied with a module 4 crown to use standard ROA7 and ROA8 racks	1
<b>SYKCE30</b>	Solar power supply kit consisting of SYP30 photovoltaic panel, PSY24 battery box with charging control circuit and SYA1 charger	1
<b>TS</b>	Sign	1

Find out more on page → 118.

#### TECHNICAL SPECIFICATIONS

Code	RUN1500/1500P
<b>ELECTRICAL SPECIFICATIONS</b>	
Power supply (VAC 50/60 Hz)	230
Draw (A)	2
Power (W)	400
<b>PERFORMANCE DATA</b>	
Speed (m/s)	0,25
Force (N)	1000
Working cycle (cycles/hour)	60
<b>DIMENSIONAL AND GENERAL DATA</b>	
Protection class (IP)	44
Operating temperature (°C Min/Max)	-20 ÷ +50
Dimensions (mm)	400x252x390 h
Weight (kg)	19

#### DIMENSIONS

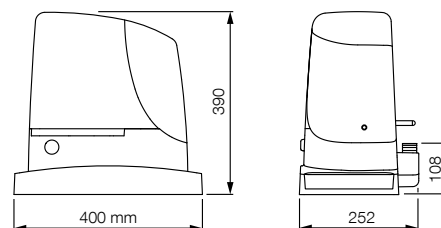

#### COMPATIBILITY WITH CONTROL SYSTEMS AND ACCESSORIES

RUN1500/1500P
<b>Control unit/Receiver</b>
<b>Integrated*</b>
• <b>OXIBD / OXILR</b>
<b>Transmitter</b>
• <b>ERA INTI</b> - 2 channels, 433.92 MHz, different colours
• <b>ERA ONE / MYGO</b> - 2, 4 or 8 channels, 433.92 MHz
• <b>MYGOBD / ERA ONE LR</b>
• <b>DOMI</b>
<b>Photocells</b>
<b>EPS</b> - Slim / <b>EPM</b> - Medium / <b>EPL</b> - Large
• <b>EPSB</b> - Slim, BlueBUS / <b>EPMB</b> - Medium, BlueBUS / <b>EPLB</b> - Large, BlueBUS
• <b>EPMOR</b> - Medium, reflective
• <b>EPMORB</b> - Medium, BlueBUS, reflective
• <b>EPMOW</b> - Medium, wireless self-synchronised
<b>F210</b> - Synchronised, adjustable / <b>FT210</b> - For sensitive edges
• <b>F210B</b> - BlueBUS
<b>FT210B</b> - For sensitive edges, BlueBUS
<b>Flashing light</b>
<b>ELAC</b>
• <b>ELDC</b>
• <b>WLT</b> - Multifunction LED light

\* Radio receiver not compatible with the O-box functions of the Opera system.

Nice

# Run 1800/2500

To automate sliding gates up to 1800 kg (RUN1800) and 2500 kg (RUN2500).

Suitable for use in extreme conditions and in systems intended for intensive use.



Compartment for control unit  
protected by pull-out box

Base and release  
in epoxy-painted  
die-cast aluminium

Self-ventilated motor with inductive limit switch (RUN1800P/RUN2500P) and electromechanical limit switch (RUN1800/RUN2500/RUN2500I).

**Easy to install:** the BlueBUS system allows connections with just two wires between the control unit and up to 15 control, safety and signalling devices.

**Safe:** the acceleration (at the start of the manoeuvre) and deceleration (at the end of the manoeuvre) settings are precise and reliable.

**Advanced temperature sensor:** Run is able to manage its force, adapting it to the different climatic and environmental conditions while at the same time adjusting the thermal protection and self-ventilation intensity depending on the temperature detected.

**Master/slave selection:** also automatically synchronises 2 motors, allowing automation of sliding gates with two opposing leaves.

**Practical and functional:** the control unit (and the inverter in the RUN2500I version) housed in Run can be connected via a practical plug-in connector.

**Quiet:** gearmotor on bearings.

**RUN2500I version with integrated inverter.**

**Flawless movement:** the inverter enables the three-phase motor to be powered and operated with 230 VAC single-phase current, adjusting the frequency to regulate the automation speed from a minimum of 8.2 m/min to a maximum of 15.4 m/min. During the automation deceleration phase, the inverter communicates with the control unit and increases the torque, improving performance and reducing the risk of the automation blocking in the presence of obstacles.

BlueBus

BiDi

230-250V

Yubii

Opera

Programmable via  
App

With Pro-View  
or BiDi-WiFi Ext &  
MyNice Pro  
App.



Code	Description	Pcs./Pallet
<b>RUN1800</b>	Non-reversible, 230-250V, with integrated control unit, electromechanical limit switch for gates up to 1800 kg	18
<b>RUN1800P</b>	Non-reversible, 230-250V, with integrated control unit, inductive limit switch for gates up to 1800 kg	18
<b>RUN2500</b>	Non-reversible, 230-250V, with integrated control unit, electromechanical limit switch for gates up to 2500 kg	18
<b>RUN2500P</b>	Non-reversible, 230-250V, with integrated control unit, inductive limit switch for gates up to 2500 kg	18
<b>RUN2500I</b>	Non-reversible, 230-250V, with built-in control unit and inverter, electromechanical limit switch, for gates up to 2500 kg	18

**COMMON ACCESSORIES**

Code	Description	Pcs. Pack
<b>SPRUA1</b>	Spare control unit for RUN1800/1800P and RUN2500/2500P	1
<b>SPRUA2</b>	Spare control unit for RUN2500I	1
<b>RUA3</b>	Spare inverter for RUN2500I	1
<b>ROA7</b>	Galvanised rack, M4 22x22x1000 mm	10
<b>ROA8</b>	Galvanised rack, M4 30x8x1000 mm, with screws and spacers	10
<b>ROA81</b>	Galvanised rack M6 30x30x1000 mm, weld-on, for use with RUA12 crown	10
<b>RUA12</b>	12-tooth crown, module 6, for use with ROA81 rack. Run is supplied with a module 4 crown to use standard ROA7 and ROA8 racks	1
<b>TS</b>	Sign	1

Find out more on page → 118.

**TECHNICAL SPECIFICATIONS**

Code	RUN1800/1800P	RUN2500/2500P	RUN2500I
<b>ELECTRICAL SPECIFICATIONS</b>			
Power supply (V/Hz)	230-250/50*		230-250/50-60
Draw (A)	3	3,8	3,7
Power (W)	700	870	650
<b>PERFORMANCE DATA</b>			
Speed (m/s)	0,17		0,26
Force (N)	1110	1390	1660
Working cycle (cycles/hour)	42		56
<b>DIMENSIONAL AND GENERAL DATA</b>			
Protection class (IP)	44		
Operating temperature (°C Min/Max)	-20 ÷ +50		
Dimensions (mm)	400x255x390 h		
Weight (kg)	24,5		25

\* 60 Hz version available on request.

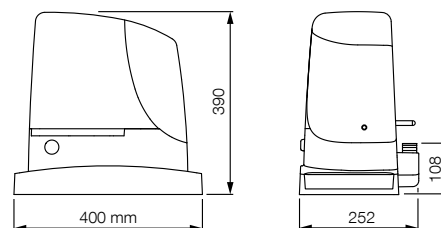
**DIMENSIONS****COMPATIBILITY WITH CONTROL SYSTEMS AND ACCESSORIES**

RUN1800/1800P RUN2500/2500P RUN2500I	Control unit/Receiver
	<b>Integrated*</b>
	• • • OXIBD / OXILR
	<b>Transmitter</b>
	• • • ERA INTI - 2 channels, 433.92 MHz, different colours
	• • • ERA ONE / MYGO - 2, 4 or 8 channels, 433.92 MHz
	• • • MYGOBD / ERA ONE LR
	• • • DOMi
	<b>Photocells</b>
	EPS - Slim / EPM - Medium / EPL - Large
	• • • EPSB - Slim, BlueBUS / EPMB - Medium, BlueBUS / EPLB - Large, BlueBUS
	EPMOR - Medium, reflective
	• • • EPMORB - Medium, BlueBUS, reflective
	• • • EPMOW - Medium, wireless self-synchronised
	F210 - Synchronised, adjustable / FT210 - For sensitive edges
	• • • F210B - BlueBUS
	• • • FT210B - For sensitive edges, BlueBUS
	<b>Flashing light</b>
	• • • ELAC
	ELDC
	WLT - Multifunction LED light

\* Radio receiver not compatible with the O-box functions of the Opera system.

Nice

# Tub

**For sliding gates up to 4000 kg.**

Ideal for industrial applications.



Self-ventilated motor to increase the work cycle

400V

BiDi

Yubii

Opera

**Programmable via App**

With Pro-View or Bidi-WiFi & MyNice Pro App.



Non-reversible 400 VAC electromechanical gearmotor, with built-in D-PRO 500 control unit.

**Powerful:** ideal for automating large industrial gates.

**Functionality and safety:** programmable, with electromechanical brake to eliminate gate inertia. Self-ventilated motor to increase the work cycle.

**Maximum durability and silent operation:** metal and bronze gears.

**Advanced:** Tub satisfies all control needs thanks to the possibility of easily and precisely managing the various functions with the Pro-View programmer.

**Practical:** the lever release makes this operation easy and safe.

Code	Description
<b>TUB4000</b>	Non-reversible electromechanical gearmotor, 400 VAC, with built-in D-PRO 500 control unit

#### TECHNICAL SPECIFICATIONS

Code	TUB4000
<b>ELECTRICAL SPECIFICATIONS</b>	
Power supply (VAC 50 Hz)*	400
Draw (A)	1,6
Power (W)	580
<b>PERFORMANCE DATA</b>	
Speed (m/s)	0,16
Force (N)	7740
Working cycle (cycles/hour)**	42
<b>DIMENSIONAL AND GENERAL DATA</b>	
Protection class (IP)	54
Operating temperature (°C Min/Max)	-20 ÷ +50
Dimensions (mm)	480x240x580 h
Weight (kg)	60

\* Can also be used at 60 Hz with corresponding change in performance. \*\* With leaves up to 5 m.

#### COMMON ACCESSORIES

Code	Description	Pcs. Pack
<b>DPRO500</b>	Control units	1
<b>NDA040</b>	For optional potential free outputs	1
<b>ROA81</b>	Galvanised rack M6 30x30x1000 mm, weld-on, for use with RUA12 crown	10
<b>TS</b>	Sign	1

Find out more on page → 118.

## DIMENSIONS

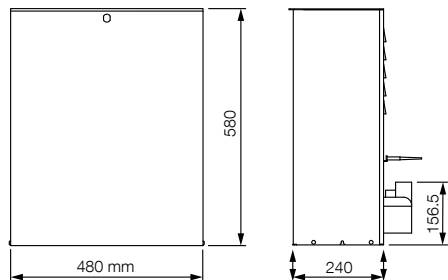

## COMPATIBILITY WITH CONTROL SYSTEMS AND ACCESSORIES

TUB4000

**Control unit/Receiver****Integrated\***

- OXIBD / OXILR

**Transmitter**

- ERA INTI - 2 channels, 433.92 MHz, different colours
- ERA ONE / MYGO - 2, 4 or 8 channels, 433.92 MHz
- MYGOBD / ERA ONE LR

- DOMi

**Photocells**

- EPS - Slim / EPM - Medium / EPL - Large
- EPSB - Slim, BlueBUS / EPMB - Medium, BlueBUS / EPLB - Large, BlueBUS
- EPMOR - Medium, reflective
- EPMORB - Medium, BlueBUS, reflective
- EPMOW - Medium, wireless self-synchronised
- F210 - Synchronised, adjustable / FT210 - For sensitive edges
- F210B - BlueBUS
- FT210B - For sensitive edges, BlueBUS

**Flashing light**

- ELAC
- ELDC
- WLT - Multifunction LED light

\* Radio receiver not compatible with the O-box functions of the Opera system.



## Accessories for sliding gates

### SPARE CONTROL UNITS



- |  |   |   |   |  |  |  |  |   |   |   |
|--|---|---|---|--|--|--|--|---|---|---|
| <p><b>SPNKA3R10</b><br/>Control unit for Naked and Slight.<br/>Pcs./pack 1</p> | <p><b>SPMCU1</b><br/>Spare control unit for RBS400/600.<br/>Pcs./pack 1</p> | <p><b>SPRBA3R10</b><br/>Spare control unit for RB400, RB600/600P, RB1000/1000P and RUN1500/1500P.<br/>Pcs./pack 1</p> | <p><b>SPRBA4R10</b><br/>Spare control unit for RDKCE.<br/>Pcs./pack 1</p> | <p><b>SPROA41R30</b><br/>Spare control unit for RO600.<br/>Pcs./pack 1</p> | <p><b>SPROA42</b><br/>Spare control unit for ROBO1000.<br/>Pcs./pack 1</p> | <p><b>SPROA43</b><br/>Spare control unit for ROBO1500.<br/>Pcs./pack 1</p> | <p><b>SPRUA1</b><br/>Spare control unit for RUN1800/1800P and RUN2500/2500P.<br/>Pcs./pack 1</p> | <p><b>SPRUA2</b><br/>Spare control unit for RUN2500I.<br/>Pcs./pack 1</p> | <p><b>RUA3</b><br/>Spare inverter for RUN2500I.<br/>Pcs./pack 1</p> | <p><b>DPRO500</b><br/>Control unit for TUB4000.<br/>Pcs./pack 1</p> |
|--|---|---|---|--|--|--|--|---|---|---|

### EXPANSION BOARD FOR CONTROL UNIT MLA1



- |  |   |  |
|--|---|--|
| <p><b>MLAE21</b><br/>Plug-in expansion board<br/>1 Output 2 Input.<br/>Pcs./pack 1</p> | <p><b>MLAE22</b><br/>Plug-in expansion board<br/>2 Output (1 230V Relay)<br/>2 Input.<br/>Pcs./pack 1</p> | <p><b>MLAE44</b><br/>Plug-in expansion board<br/>4 Output 4 Input.<br/>Pcs./pack 1</p> |
|--|---|--|

### RACKS



- |  |  |  |  |   |
|--|--|--|--|---|
| <p><b>ROA6</b><br/>Slotted rack, M4<br/>25x20x1000 mm, nylon with metal insert. For gates up to 500 kg.<br/>Pcs./pack 10</p> | <p><b>ROA66</b><br/>Slotted nylon rack M4<br/>25x20x1000 mm with metal core, six fastening points. For gates weighing up to 800 kg.<br/>Pcs./pack 10</p> | <p><b>ROA7</b><br/>Galvanised rack, M4<br/>22x22x1000 mm.<br/>Pcs./pack 10</p> | <p><b>ROA8</b><br/>Galvanised rack, M4<br/>30x8x1000 mm, with screws and spacers.<br/>Pcs./pack 10</p> | <p><b>ROA81</b><br/>Galvanised rack M6<br/>30x30x1000 mm, weld-on, for use with RUA12 crown.<br/>Pcs./pack 10</p> |
|--|--|--|--|---|

### ADAPTER PLATES FOR ROBUS



- CBIPLERB6**  
Retrofitting kit replacing Nice RB600.  
Pcs./pack 1

## OTHER ACCESSORIES



**RUA12**  
12-tooth crown gear,  
module 6, for use with  
ROA81 rack (solely for  
Run).

Pcs./pack 1



**RBA1**  
Inductive limit switch.  
Pcs./pack 1



**KIO**  
Key switch for low-volt-  
age contacts, with  
release mechanism for  
metal cable.  
Pcs./pack 1



**KA1**  
Kit with 6 m metal cable  
for KIO.  
Pcs./pack 1



**CM-B**  
Release ratchet with two  
metal keys.  
Pcs./pack 1



**NDA040**  
For optional potential  
free outputs.  
Pcs./pack 1



**TS**  
Sign.  
Pcs./pack 1

## ACCESSORIES FOR 24 V VERSIONS



**PSS124**  
24 V battery with inte-  
grated battery charger.  
Pcs./pack 1



**SYKCE30**  
Solar power supply kit consisting of SYP30 photo-  
voltaic panel and PSY24 battery box with charging  
control circuit and SYA1 power supply.  
Pcs./pack 1

Solemyo

24V

# Nice

## Standard installation diagram for sliding gates

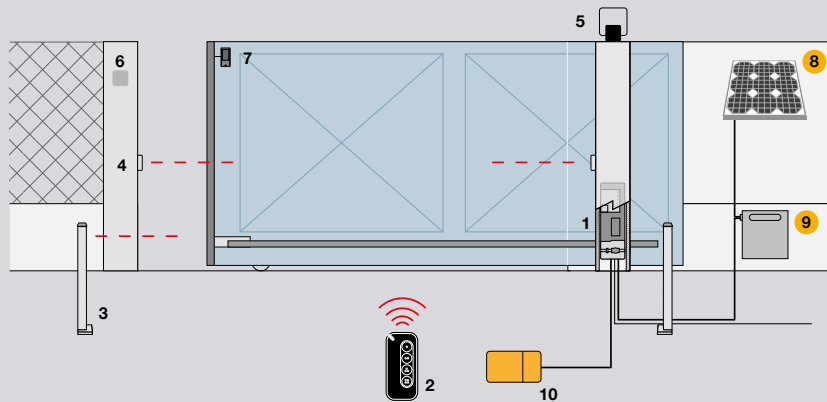

### NAKED

1. Motor 2. Transmitter 3. Post-mounted photocells 4. Photocells 5. Flashing light 6. Key switch 7. Sensor for sensitive edge 8. SYP30 solar panel 9. PSY24 battery box 10. Pro-View multifunction interface

● Solemyo solar power accessories

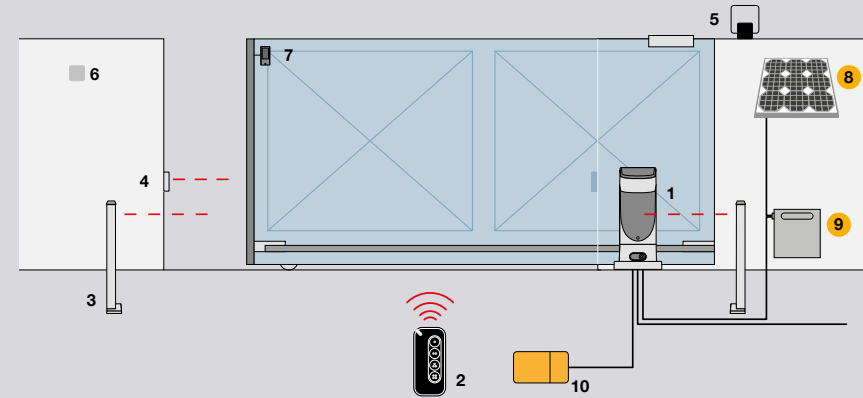

### SLIGHT

1. Motor 2. Transmitter 3. Post-mounted photocells 4. Photocells 5. Flashing light 6. Key switch 7. Sensor for sensitive edge 8. SYP30 solar panel 9. PSY24 battery box 10. Pro-View multifunction interface

● Solemyo solar power accessories

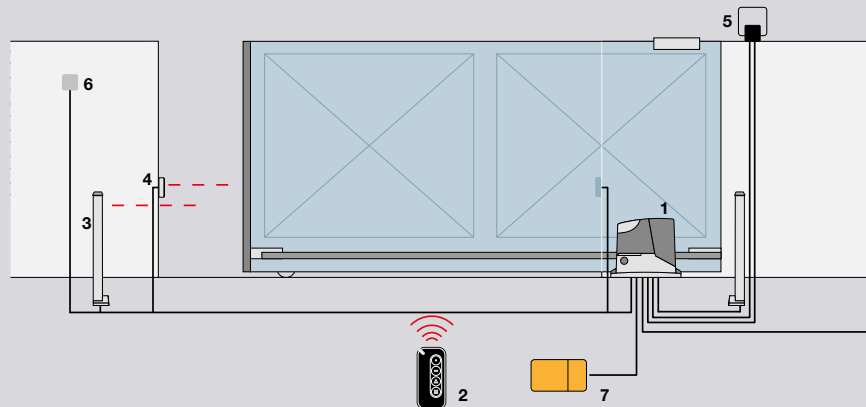

### ROAD

1. Motor 2. Transmitter 3. Post-mounted photocells 4. Photocells 5. Flashing light 6. Key switch 7. Pro-View multifunction interface

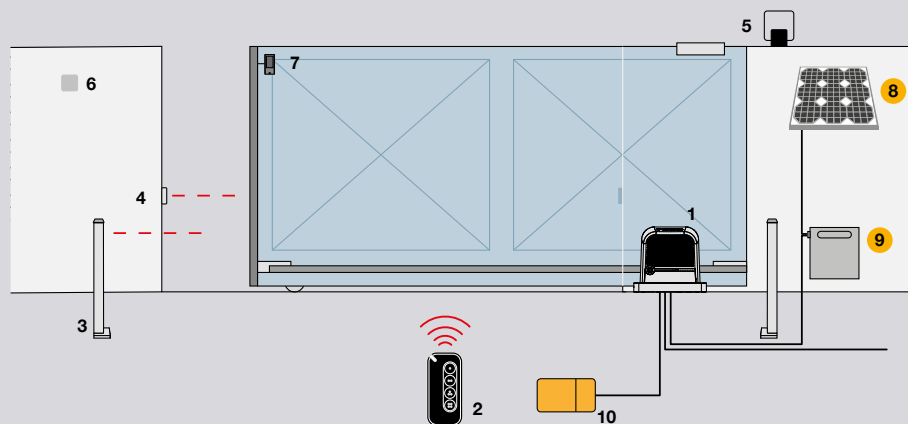

**ROBUS 400/600, ROBUS 400/600/1000**

1. Motor 2. Transmitter 3. Post-mounted photocells 4. Photocells 5. Flashing light 6. Key switch 7. Sensor for sensitive edge 8. SYP30 solar panel 9. PSY24 battery box 10. Pro-View multifunction interface

● Solemyo solar power accessories

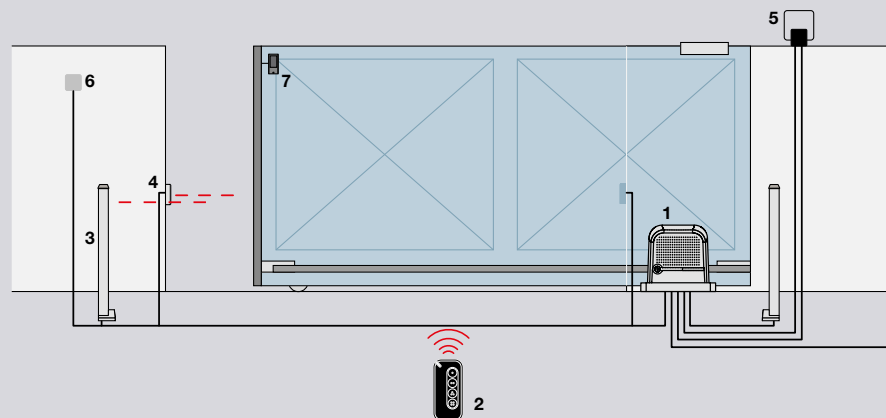

**ROBO 600, ROBO 1000/1500**

1. Motor 2. Transmitter 3. Post-mounted photocells 4. Photocells 5. Flashing light 6. Key switch 7. Sensor for sensitive edge

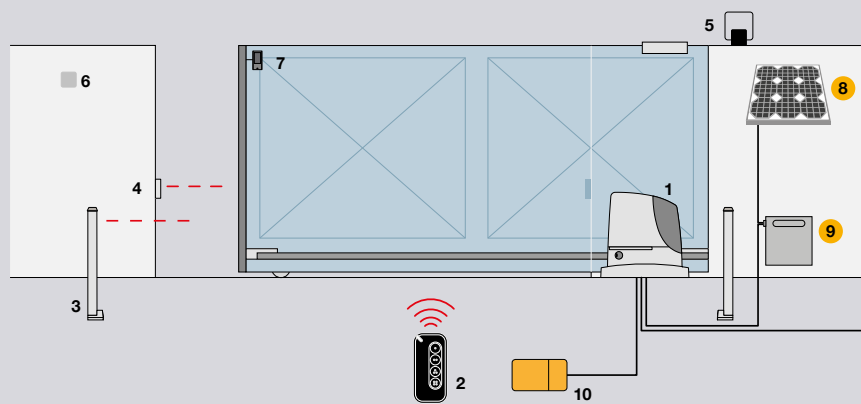

## RUN 1500

1. Motor 2. Transmitter 3. Post-mounted photocells 4. Photocells 5. Flashing light 6. Key switch 7. Sensor for sensitive edge 8. SYP30 solar panel 9. PSY24 battery box 10. Pro-View multifunction interface

● Solemyo solar power accessories

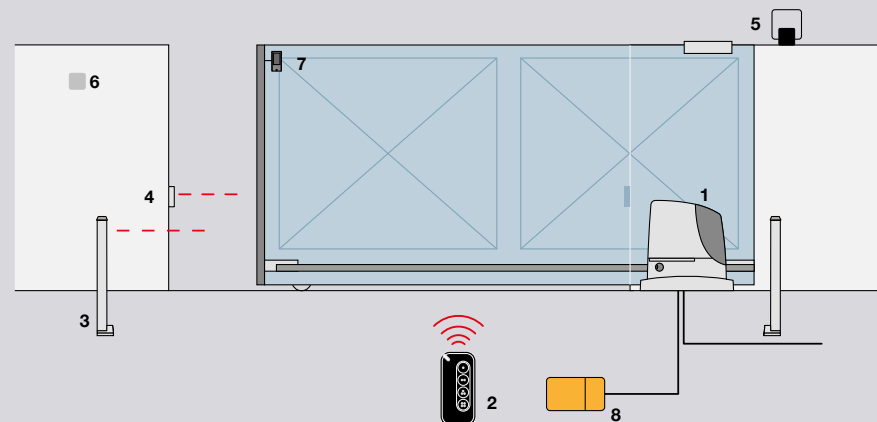

## RUN 1800/2500

1. Motor 2. Transmitter 3. Post-mounted photocells 4. Photocells 5. Flashing light 6. Key switch 7. Sensor for sensitive edge 8. Pro-View multifunction interface

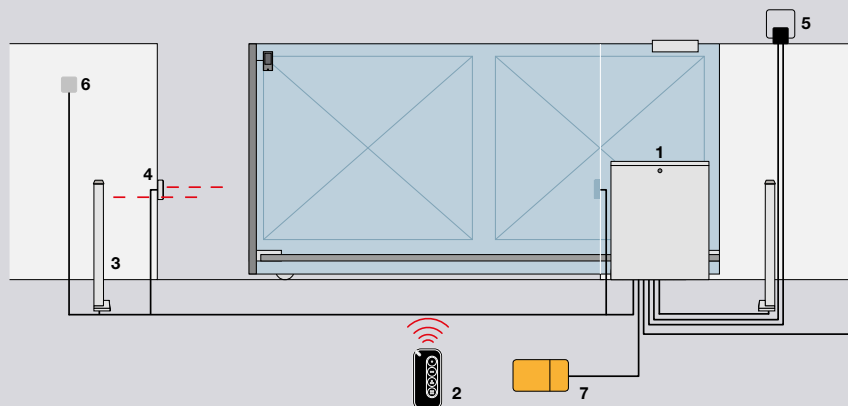

## TUB

1. Motor 2. Transmitter 3. Post-mounted photocells 4. Photocells 5. Flashing light 6. Key switch 7. Pro-View multifunction interface



Nice

# S/M/L Bar

## Barrier raising systems for every size.

Barrier raising systems for controlling road access in parking areas and private and apartment block access roads, including with heavy traffic.

### Integrated solutions for all needs.

Performance, reliability and a long working life.  
Essential elegant design.  
Meticulous research into materials.  
Greater comfort and safety at all times.



Index

New

#### M-Bar and L-Bar

are now available with high-visibility red/green LEDs on the top cover and on the top and bottom of the bar, plus a transparent bumper rubber for better visibility

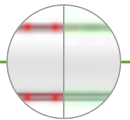

#### Painted aluminium

bar support and cover, with optional flashing light

#### With case in

steel with protective electrophoretic treatment and painted, or case in stainless steel

#### Four colour versions

M-Bar and L-Bar are available in orange, stainless steel, white and grey



**ORANGE**  
RAL2004



**STEEL INOX**  
AISI 304



**WHITE**  
RAL9010



**GREY**  
RAL7015

**Quick and easy access to internal components**

- simple removal of cover, separate compartments to protect electronics and mechanics.



**Balancing springs** - highly robust, guaranteed for up to **3,000,000** manoeuvres for M-Bar and L-Bar models.

**Gearmotor** - 24 VDC, powerful and fast.

**Control unit located in the upper part of the barrier body** - easier programming and maintenance.



**Photocells completely invisible from the outside** - fixed simply in place in the recesses provided in the barrier body.

**Key release** for installation on either side

**Flashing light or optional traffic light** for integrated installation in cover



**Elliptical section bar with high resistance to gusts of wind.** LED signal lights for integrated installation in the profile

**5 models and 3 versions available, up to 7 modular bars from 3 to 9 m long.**

The practical composition of the bars with aluminium expansion joint guarantees their robustness and makes them easier to transport and handle at the warehouse.

To obtain a complete barrier raising system:

1. Choose the gearmotor
2. Associate the bar
3. Complete the system with optional accessories.

## Composition bars and accessories

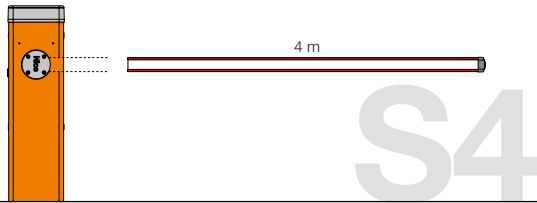

### S4BAR

**With dedicated 4 m bar**

Provision for:  
protective rubber trim, signal lights.

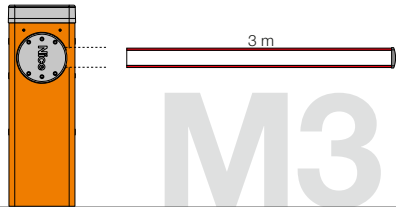

### M3BAR

**With 3 m long bar**

Provision for:  
protective rubber trim, signal lights.

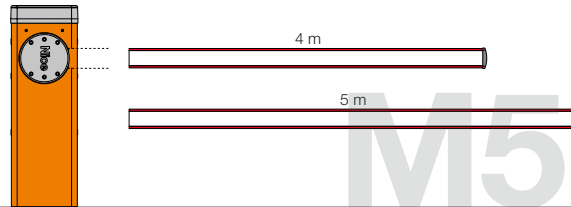

### M5BAR

**With 4 m long bar**

Provision for:  
protective rubber trim, signal lights,  
rack (1 pc.), movable support.

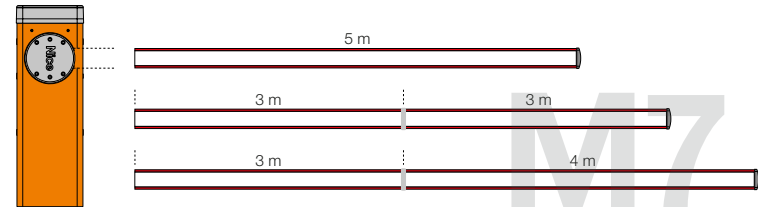

### M7BAR

**With 5 m long bar**

Provision for:  
protective rubber trim,  
signal lights, rack (2 pc.),  
movable support.

**With 6 m bar (3+3 m)\***

Provision for:  
protective rubber trim, signal lights,  
rack (2 pc.), movable support.

**With 7 m bar (3+4 m)\***

Provision for:  
protective rubber trim, signal lights,  
movable support.

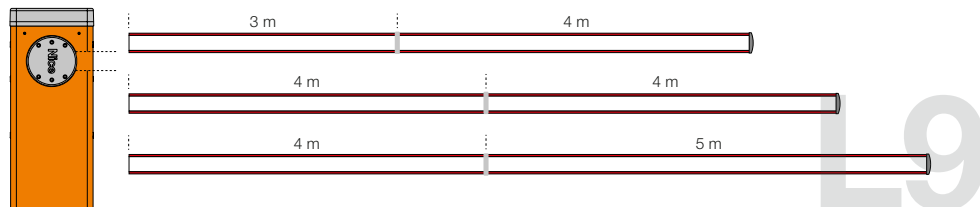

### L9BAR

**With 7 m bar (3+4 m)\***

Provision for:  
protective rubber trim, signal lights, rack  
(3 pc.), movable support.

**With 8 m bar (4+4 m)\***

Provision for:  
protective rubber trim, signal lights, rack  
(3 pc.), movable support.

**With 9 m bar (4+5 m)\***

Provision for:  
protective rubber trim, signal lights.

\* Use joint XBA9 to assemble the bars. **N.B.** Bars and accessories are not included in the gearmotor code.

Nice

# S-Bar

## Electromechanical road barrier system for road access control.

For 4 m bars.



BlueBus

BiDi

Programmable via  
App

24V

Yubii

With Pro-View or  
Bidi-WiFi & MyNice  
Pro App.

Solemyo

Opera



Gearmotor, 24 VDC, with integrated control unit.

**Strength and reliability:** sturdy steel structure, new robust balancing springs guaranteed to 500,000 cycles and elliptical section bar with high resistance to gusts of wind.

Optional flashing light for integrated installation in cover.

**Easier programming and maintenance:**

separate compartments for the electronics and mechanics protect internal parts from possible hazards.

Quick and easy access to the control unit located in the top part of the barrier body.

The photocells, completely invisible from the outside, are fixed simply in place in the recesses provided in the barrier body.

**More reliability and safety:** obstacle detection and monitoring of motor draw throughout automation movement.

Automatic fault diagnosis during operation and subsequent indication of type through different combinations of flashes.

Provision for connection of latest generation optical and resistive sensitive edges (8.2 KOhm resistance).

**Energy saving:** when the system is not in use, it switches to stand-by mode at <0.3W, reducing power consumption.

**No blackouts:** operation in event of power failures with the optional batteries housed under the control unit.

**Side release with Nice triangular key:** can be installed on either side.

## TO OBTAIN A COMPLETE BARRIER RAISING SYSTEM:

1. CHOOSE THE GEARMOTOR

2. ASSOCIATE THE BAR

3. COMPLETE THE SYSTEM  
WITH OPTIONAL ACCESSORIES

For 4 m long bars, non-reversible 230 VAC, 24 VDC motor, including anchorage base:

Code	Description
<b>S4BAR</b>	With case in steel and with protective electrophoretic treatment and painted
<b>S4BARI</b>	With stainless steel case

## COMMON ACCESSORIES

Code	Description	Pcs. Pack
<b>XBA19</b>	White painted aluminium bar 45x58x4270 mm	1
<b>SPXBA20R30</b>	Spare control unit for S4BAR	1
<b>XBA13</b>	Bumper rubber, 1 m	9
<b>WA10</b>	Red reflective adhesive strip	24
<b>SIA1</b>	Anchorage base with clamps	1
<b>XBA7</b>	Flashing light for integrated installation in cover	1
<b>XBA4</b>	Plug-in signal lights for mounting on the top or bottom of the bar. Length 4 m	1
<b>WA11</b>	Adjustable support for bars	1
<b>PSS124</b>	24 V battery with integrated battery charger	1
<b>SYKCE30</b>	Solar power supply kit consisting of SYP30 photovoltaic panel, PSY24 battery box with charging control circuit and SYA1 charger	1

Find out more on page → 138.

## TECHNICAL SPECIFICATIONS

Code	S4BAR	S4BARI
<b>ELECTRICAL SPECIFICATIONS</b>		
Power supply (VAC 50/60 Hz)		230
Power supply (VDC)		24
Power (W)		300
Power in standby (W)		<0.3
<b>PERFORMANCE DATA</b>		
Speed (S)		≥4 - >5 (with XBA4 accessory)
Torque (Nm)		100
Working cycle (cycles/hour)*		100
<b>DIMENSIONAL AND GENERAL DATA</b>		
Protection class (IP)		44
Operating temperature (°C Min/Max)		-20 ÷ +55
Dimensions (mm)		330x179,5x1146 h
Weight (kg)		35

\* At nominal torque.

## DIMENSIONS

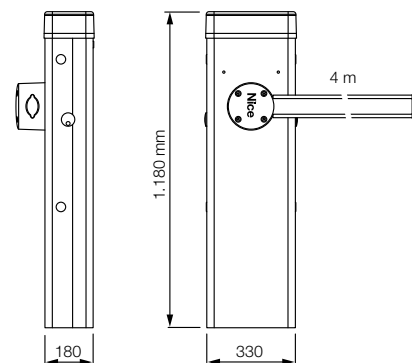

## COMPATIBILITY WITH CONTROL SYSTEMS AND ACCESSORIES

S4BAR S4BARI	Control unit/Receiver
	<b>Integrated*</b>
	• • OXIBD / OXILR
	<b>Transmitter</b>
	• • ERA INTI - 2 channels, 433.92 MHz, different colours
	• • ERA ONE / MYGO - 2, 4 or 8 channels, 433.92 MHz
	• • MYGOBD / ERA ONE LR
	• • DOMi
	<b>Photocells</b>
	<b>EPS</b> - Slim / <b>EPM</b> - Medium / <b>EPL</b> - Large
	• • EPSB - Slim, BlueBUS / <b>EPMB</b> - Medium, BlueBUS / <b>EPLB</b> - Large, BlueBUS
	• • EPMOR - Medium, reflective
	<b>EPMORB</b> - Medium, BlueBUS, reflective
	• • EPMOW - Medium, wireless self-synchronised
	<b>F210</b> - Synchronised, adjustable / <b>FT210</b> - For sensitive edges
	• • F210B - BlueBUS
	• • FT210B - For sensitive edges, BlueBUS
	<b>Flashing light</b>
	<b>ELAC</b>
	• • ELDC
	• • WLT - Multifunction LED light

\* Radio receiver not compatible with the O-box functions of the Opera system.

Nice

# M-Bar

## Electromechanical road barrier system for road access control.

For bars from 3 to 7 m long.



\* Use joint XBA9 to assemble the bars.

BlueBus

BiDi

Programmable via App

With Pro-View or  
Bidi-WiFi & MyNice  
Pro App.



24V

Yubii

Solemyo

Opera

Gearmotor, 24 VDC, with integrated control unit.

**Simplified programming:** control unit with display and joystick to make setting operating parameters even faster.

The control unit has an output to power 24 VDC devices and two inputs to control loop detectors via the LP21 and LP22 accessories.

**Modular:** practical composition of the bars with the aluminium expansion joint.

Smart control of the movement of two opposing automations thanks to the **“master/slave” function.**

**Strength and reliability:** sturdy steel structure, new robust balancing springs guaranteed for up to **3,000,000** cycles and elliptical section bar with high resistance to gusts of wind.

Optional flashing or traffic light for integrated installation in cover.

Movement control with encoder and electromechanical limit switches.

**Two container versions,** in galvanized and painted steel, or stainless (AISI 304) **in three sizes for rods from 3 to 7 meters**

**Easier programming and maintenance:** separate compartments for the electronics and mechanics protect internal parts from possible hazards.

Quick and easy access to the control unit located in the top part of the barrier body.

The photocells, completely invisible from the outside, are fixed simply in place in the recesses provided in the barrier body.

**More reliability and safety:** obstacle detection and monitoring of motor draw throughout automation movement.

Automatic fault diagnosis during operation and subsequent indication of type through different combinations of flashes.

Provision for connection of latest generation optical and resistive sensitive edges (8.2 KOhm resistance).

**Energy saving:** when the system is not in use, it switches to stand-by mode, reducing power consumption.

**No blackouts:** operation in event of power failure with the optional batteries (PS224) housed in the motor.

**Side release with metal key:** can be installed on either side.

**For 3 m** long bars, non-reversible 230 VAC, 24 VDC motor, including anchorage base:

Code	Description
<b>M3BAR</b>	Steel case, protective cataphoresis treatment, painted orange. For intensive use
<b>M3BARI</b>	With stainless steel case
<b>M3BARWH</b>	Steel case, protective cataphoresis treatment, painted white. For intensive use
<b>M3BARGR1</b>	Steel case, protective cataphoresis treatment, painted grey. For intensive use

**For 4 or 5 m** long bars, non-reversible 230 VAC, 24 VDC motor, including anchorage base:

Code	Description
<b>M5BAR</b>	Steel case, protective cataphoresis treatment, painted orange. For intensive use
<b>M5BARI</b>	With stainless steel case
<b>M5BARWH</b>	Steel case, protective cataphoresis treatment, painted white. For intensive use
<b>M5BARGR1</b>	Steel case, protective cataphoresis treatment, painted grey. For intensive use

**For 5, 6 or 7 m** long bars, non-reversible 230 VAC, 24 VDC motor, including anchorage base:

Code	Description
<b>M7BAR</b>	Steel case, protective cataphoresis treatment, painted orange. For intensive use
<b>M7BARI</b>	With stainless steel case
<b>M7BARWH</b>	Steel case, protective cataphoresis treatment, painted white. For intensive use
<b>M7BARGR1</b>	Steel case, protective cataphoresis treatment, painted grey. For intensive use

## TO OBTAIN A COMPLETE BARRIER RAISING SYSTEM:

1. CHOOSE THE GEARMOTOR

2. ASSOCIATE THE BAR

3. COMPLETE THE SYSTEM  
WITH OPTIONAL ACCESSORIES

## COMMON ACCESSORIES

Code	Description	Pcs. Pack
<b>BCU1</b>	Control units	1
<b>LP21</b>	Magnetic loop detector 1 channel	1
<b>LP22</b>	Magnetic loop detector 2 channels	1
<b>XBA13T</b>	Transparent bumper rubber, 1 m	9
<b>XBA13</b>	Bumper rubber, 1 m	9
<b>WA10</b>	Red reflective adhesive strip	24
<b>XBA8</b>	Traffic light for integrated installation in cover	1
<b>XBA7</b>	Flashing light for integrated installation in cover	1
<b>XBA16</b>	Anchorage base with clamps	1
<b>WA11</b>	Adjustable support for bars	1
<b>PS224</b>	Buffer battery 24 VDC	1
<b>SYKCE30</b>	Solar power supply kit consisting of SYP30 photovoltaic panel, PSY24 battery box with charging control circuit and SYA1 charger	1

## ACCESSORIES FOR M3BAR

Code	Description	Pcs. Pack
<b>XBA15</b>	White painted aluminium bar 69x92x3150 mm	1
<b>XBA40</b>	Plug-in RG signal lights for mounting on the top or bottom of the bar. Length 4 m	1
<b>XBA4</b>	Plug-in signal lights for mounting on the top or bottom of the bar. Length 4 m	1
<b>XBA10</b>	Swivel attachment for bars up to 4 m long	1
<b>XBA11</b>	Joint for bars (1950 mm to 2400 mm)	1

## ACCESSORIES FOR M5BAR

Code	Description	Pcs. Pack
<b>XBA14</b>	White painted aluminium bar 69x92x4150 mm	1
<b>XBA5</b>	White painted aluminium bar 69x92x5150 mm	1
<b>XBA40</b>	Plug-in RG signal lights for mounting on the top or bottom of the bar. Length 4 m	1
<b>XBA4</b>	Plug-in signal lights for mounting on the top or bottom of the bar. Length 4 m	1
<b>XBA60</b>	Plug-in RG signal lights for mounting on the top or bottom of the bar. Length 6 m	1
<b>XBA6</b>	Plug-in signal lights for mounting on the top or bottom of the bar. Length 6 m	1
<b>XBA10</b>	Swivel attachment for bars up to 4 m long	1
<b>XBA11</b>	Joint for bars (1950 mm to 2400 mm)	1
<b>WA12</b>	Movable support for bars, reinforced and resistant	1
<b>WA13</b>	Aluminium rack, 2 m	1

## ACCESSORIES FOR M7BAR

Code	Description	Pcs. Pack
<b>XBA15</b>	White painted aluminium bar 69x92x3150 mm	1
<b>XBA14</b>	White painted aluminium bar 69x92x4150 mm	1
<b>XBA5</b>	White painted aluminium bar 69x92x5150 mm	1
<b>XBA9</b>	Expansion joint	1
<b>XBA60</b>	Plug-in RG signal lights for mounting on the top or bottom of the bar. Length 6 m	1
<b>XBA6</b>	Plug-in signal lights for mounting on the top or bottom of the bar. Length 6 m	1
<b>XBA80</b>	Plug-in RG signal lights for mounting on the top or bottom of the bar. Length 8 m	1
<b>XBA18</b>	Plug-in signal lights for mounting on the top or bottom of the bar. Length 8 m	1
<b>WA12</b>	Movable support for bars, reinforced and resistant	1
<b>WA13</b>	Aluminium rack, 2 m	1

Find out more on page → 138.

## TECHNICAL SPECIFICATIONS

Code	M3BAR	M3BARI	M5BAR	M5BARI	M7BAR	M7BARI
<b>ELECTRICAL SPECIFICATIONS</b>						
Power supply (VAC 50/60 Hz)				230		
Power supply (VDC)				24		
Power (W)	150		110		110	
<b>PERFORMANCE DATA</b>						
Min-max speed (S)	1,5 ÷ 4		3 ÷ 6		6 ÷ 10	
Torque (Nm)	100		200		300	
Working cycle (cycles/hour)*	500		350		200	
Working cycle (cycles/hour)* at 60°C	350		250		150	
<b>DIMENSIONAL AND GENERAL DATA</b>						
Protection class (IP)	54					
Operating temperature (°C Min/Max)	-20 ÷ +60					
Dimensions (mm)	400x299x1215 h					
Weight (kg)	80				85	

\* At nominal torque.

## DIMENSIONS

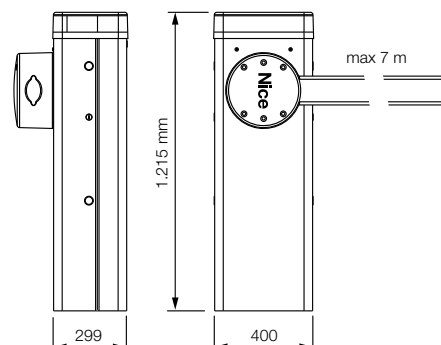

## COLOUR VERSIONS

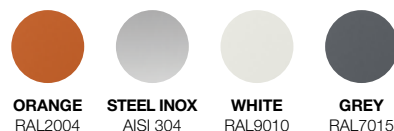

## COMPATIBILITY WITH CONTROL SYSTEMS AND ACCESSORIES

M3BAR / M3BARI	M5BAR / M5BARI	M7BAR / M7BARI	Control unit/Receiver
			<b>Integrated*</b>
•	•	•	<b>OXIBD / OXILR</b>
			<b>Transmitter</b>
•	•	•	<b>ERA INTI</b> - 2 channels, 433.92 MHz, different colours
•	•	•	<b>ERA ONE / MYGO</b> - 2, 4 or 8 channels, 433.92 MHz
•	•	•	<b>MYGOBD / ERA ONE LR</b>
•	•	•	<b>DOMi</b>
			<b>Photocells</b>
			<b>EPS</b> - Slim / <b>EPM</b> - Medium / <b>EPL</b> - Large
•	•	•	<b>EPSB</b> - Slim, BlueBUS / <b>EPMB</b> - Medium, BlueBUS / <b>EPLB</b> - Large, BlueBUS
•	•	•	<b>EPMOR</b> - Medium, reflective
			<b>EPMORB</b> - Medium, BlueBUS, reflective
•	•	•	<b>EPMOV</b> - Medium, wireless self-synchronised
•	•	•	<b>F210</b> - Synchronised, adjustable / <b>FT210</b> - For sensitive edges
•	•	•	<b>F210B</b> - BlueBUS
			<b>FT210B</b> - For sensitive edges, BlueBUS
			<b>Flashing light</b>
			<b>ELAC</b>
•	•	•	<b>ELDC</b>
•	•	•	<b>WLT</b> - Multifunction LED light

\* Radio receiver not compatible with the O-box functions of the Opera system.

Nice

# L-Bar

## Electromechanical road barrier system for road access control.

Powerful and fast, for 7 to 9 m long bars.

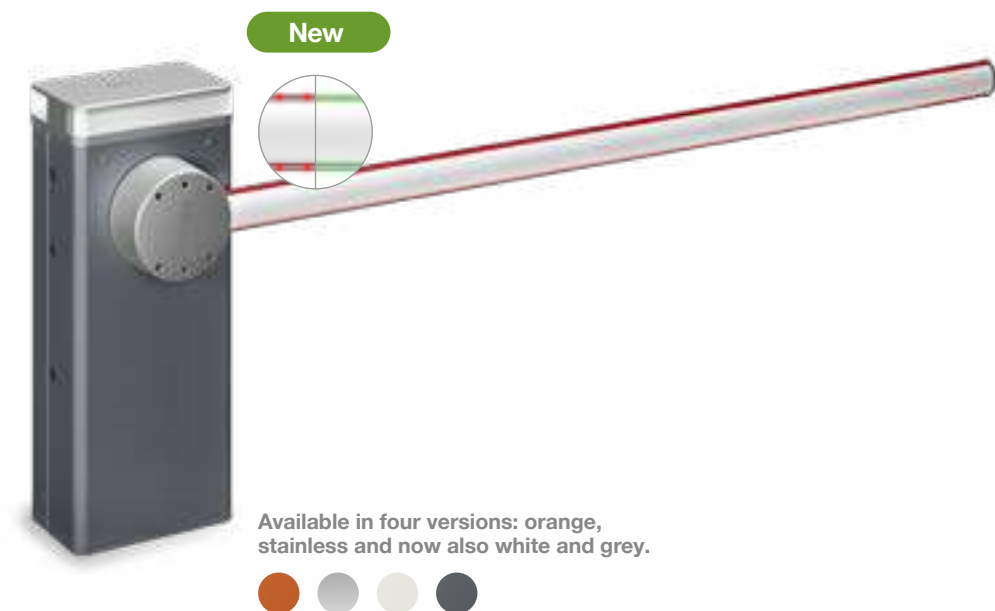

Available in four versions: orange, stainless and now also white and grey.



BlueBus

24V

BiDi

Yubii

Solemyo

Opera

Programmable via App

With Pro-View or Bidi-WiFi & MyNice Pro App.



Gearmotor, 24 VDC, with integrated control unit.

**Simplified programming:** control unit with display and joystick to make setting operating parameters even faster.

The control unit has an output to power 24 VDC devices and two inputs to control loop detectors via the LP21 and LP22 accessories.

**Modular:** practical composition of the bars with the aluminium expansion joint.

Smart control of the movement of two opposing automations thanks to the “**master/slave**” function.

**Strength and reliability:** sturdy steel structure, new robust balancing springs guaranteed for up to **3,000,000** cycles and elliptical section bar with high resistance to gusts of wind.

Optional flashing or traffic light for integrated installation in cover.

Movement control with encoder and electromechanical limit switches.

**Two container versions,** in galvanized and painted steel, or stainless (AISI 304).

**Easier programming and maintenance:** separate compartments for the electronics and mechanics protect internal parts from possible hazards.

Quick and easy access to the control unit located in the top part of the barrier body.

The photocells, completely invisible from the outside, are fixed simply in place in the recesses provided in the barrier body.

**More reliability and safety:** obstacle detection and monitoring of motor draw throughout automation movement.

Automatic fault diagnosis during operation and subsequent indication of type through different combinations of flashes.

Provision for connection of latest generation optical and resistive sensitive edges (8.2 KOhm resistance).

**Energy saving:** when the system is not in use, it switches to stand-by mode, reducing power consumption.

**No blackouts:** operation in event of power failure with the optional batteries (PS224) housed in the motor.

**Side release with metal key:** can be installed on either side.

## TO OBTAIN A COMPLETE BARRIER RAISING SYSTEM:

1. CHOOSE THE GEARMOTOR

2. ASSOCIATE THE BAR

3. COMPLETE THE SYSTEM  
WITH OPTIONAL ACCESSORIES

For 9 m long bars, non-reversible 230 VAC, 24 VDC motor, including anchorage base:

Code	Description
<b>L9BAR</b>	Steel case, protective cataphoresis treatment, painted orange
<b>L9BARI</b>	With stainless steel case
<b>L9BARWH</b>	Steel case, protective cataphoresis treatment, painted white.
<b>L9BARGR1</b>	Steel case, protective cataphoresis treatment, painted grey.

## COMMON ACCESSORIES

Code	Description	Pcs. Pack
<b>XBA15</b>	White painted aluminium bar 69x92x3150 mm	1
<b>XBA14</b>	White painted aluminium bar 69x92x4150 mm	1
<b>XBA5</b>	White painted aluminium bar 69x92x5150 mm	1
<b>XBA9</b>	Expansion joint	1
<b>XBA8</b>	Traffic light for integrated installation in cover	1
<b>XBA7</b>	Flashing light for integrated installation in cover	1
<b>XBA80</b>	Plug-in RG signal lights for mounting on the top or bottom of the bar. Length 8 m	1
<b>XBA18</b>	Plug-in signal lights for mounting on the top or bottom of the bar. Length 8 m	1
<b>BCU1</b>	Control units	1
<b>LP21</b>	Magnetic loop detector 1 channel	1
<b>LP22</b>	Magnetic loop detector 2 channels	1
<b>XBA13T</b>	Transparent bumper rubber, 1 m	9
<b>XBA13</b>	Bumper rubber, 1 m	9
<b>WA10</b>	Red reflective adhesive strip	24
<b>WA13</b>	Aluminium rack, 2 m	1
<b>XBA17</b>	Anchorage base with clamps	1
<b>WA11</b>	Adjustable support for bars	1
<b>WA12</b>	Movable support for bars, reinforced and resistant	1
<b>PS224</b>	Buffer battery 24 VDC	1
<b>SYKCE30</b>	Solar power supply kit consisting of SYP30 photovoltaic panel, PSY24 battery box with charging control circuit and SYA1 charger	1

Find out more on page → 138.

## TECHNICAL SPECIFICATIONS

Code	L9BAR	L9BARI
<b>ELECTRICAL SPECIFICATIONS</b>		
Power supply (VAC 50/60 Hz)		230
Power supply (VDC)		24
Power (W)		160
<b>PERFORMANCE DATA</b>		
Min-max speed (S)		11 ÷ 18
Torque (Nm)		400
Working cycle (cycles/hour)*		150
Working cycle (cycles/hour)* at 60°C		100
<b>DIMENSIONAL AND GENERAL DATA</b>		
Protection class (IP)		54
Operating temperature (°C Min/Max)		-20 ÷ +60
Dimensions (mm)		500x299x1215 h
Weight (kg)		98

\* At nominal torque.

## DIMENSIONS

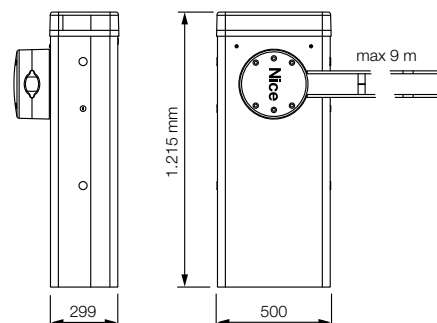

## COLOUR VERSIONS

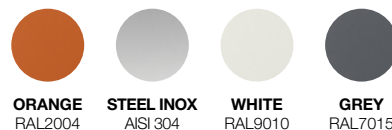
**ORANGE**  
RAL2004**STEEL INOX**  
AISI 304**WHITE**  
RAL9010**GREY**  
RAL7015

## COMPATIBILITY WITH CONTROL SYSTEMS AND ACCESSORIES

L9BAR /  
L9BARI

## Control unit/Receiver

## Integrated\*

- OXIBD / OXILR

## Transmitter

- ERA INTI - 2 channels, 433.92 MHz, different colours
- ERA ONE / MYGO - 2, 4 or 8 channels, 433.92 MHz
- MYGOBD / ERA ONE LR

- DOMI

## Photocells

- EPS - Slim / EPM - Medium / EPL - Large
- EPSB - Slim, BlueBUS / EPMB - Medium, BlueBUS / EPLB - Large, BlueBUS
- EPMOR - Medium, reflective
- EPMORB - Medium, BlueBUS, reflective
- EPMOW - Medium, wireless self-synchronised

F210 - Synchronised, adjustable / FT210 - For sensitive edges

- F210B - BlueBUS

FT210B - For sensitive edges, BlueBUS

## Flashing light

## ELAC

- ELDC
- WLT - Multifunction LED light

\* Radio receiver not compatible with the O-box functions of the Opera system.

Nice

# Wide System

## Solid and essential.



**Large front cover for quick and easy access** - easily removable reinforced gearmotor support.



**Easy maintenance** - integrated control unit, removable for ease of wiring and maintenance. No blackouts with the buffer battery for integrated installation in the control unit.



**Safety from vandals** - photocells integrated in the barrier body, minimum visual impact and maximum protection.

**WIDEM and WIDEL are available in three colour versions: grey, stainless steel and orange.**



**GREY**  
RAL7015



**STEEL  
INOX**  
AISI 304



**ORANGE**  
RAL2004

**Removable cover**  
for easy access  
to internal parts

**The bar can be mounted** on either  
the right or left side



**Release protected**  
from external agents  
and easy to operate with  
triangular key

**Case in steel**  
with protective electrophoretic  
treatment and painted, or case  
in stainless steel

## 3 versions available, up to 4 modular bars from 3 to 6 m long.

The composition of the bars with aluminium expansion joint facilitates their transport and handling in storage.

To obtain a complete barrier raising system:

1. Choose the gearmotor
2. Associate the bar
3. Complete the system with optional accessories.

### Composition bars and accessories

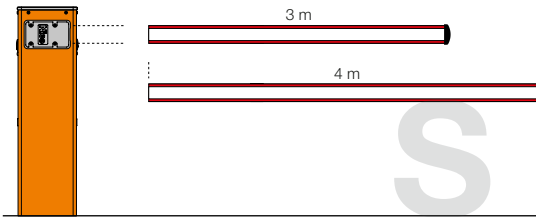

#### WIDES

##### With 3 m long bar

Provision for:  
protective rubber trim, signal lights,  
swivel attachment, rack (1 pc.).

##### With 4 m long bar

Provision for:  
protective rubber trim, signal lights,  
swivel attachment.

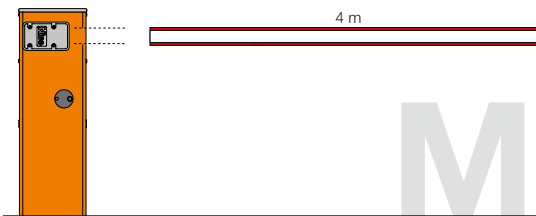

#### WIDEM

##### With 4 m bar

Provision for:  
protective rubber trim, signal lights, swivel  
attachment, jointed attachment, rack (2 pcs.),  
movable support.

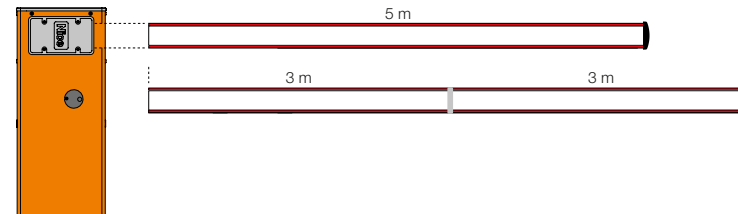

#### WIDEL

##### With 5 m long bar

Provision for:  
protective rubber trim, signal lights, rack  
(2 pc.), movable support.

##### With 6 m bar (3+3 m)\*

Provision for:  
protective rubber trim, signal lights, rack  
(2 pc.), movable support.

\* Use joint XBA9 to assemble the bars. **N.B.** Bars and accessories are not included in the gearmotor code.

Nice

# Wide System

Electromechanical road barrier system for road access control.

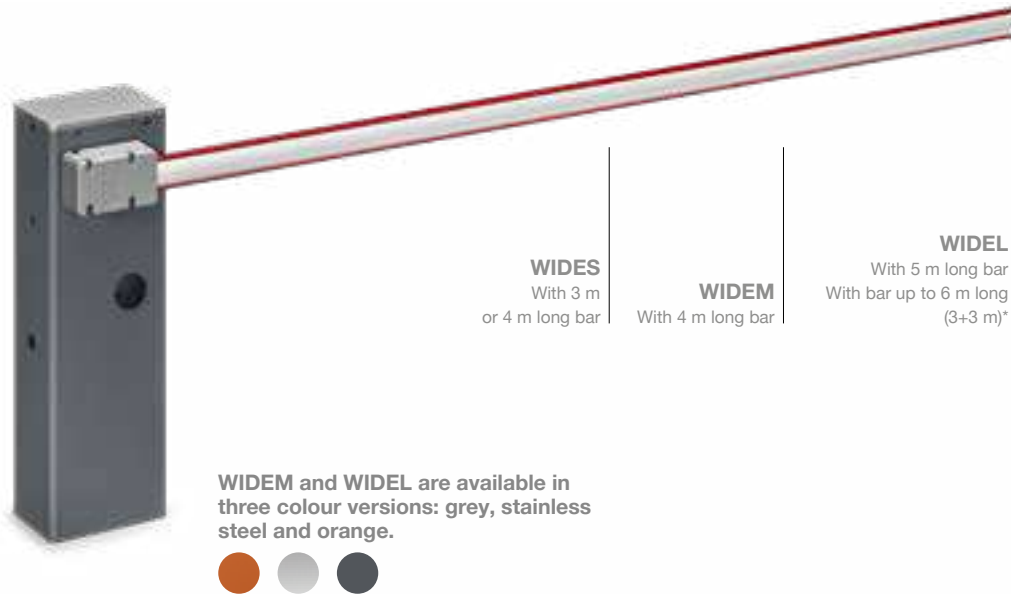

\* Use joint XBA9 to assemble the bars.

24V

BiDi

Yubii

Opera

Programmable via App

With Pro-View or Bidi-WiFi & MyNice Pro App.



Gearmotor, 24 VDC, with integrated control unit, adjustable speed and crush protection function.

**Two versions of case**, in galvanised and painted steel, or in stainless steel (AISI 304) **in three sizes for bars from 3 to 6 m long.**

**Easier programming and maintenance:** one integrated control unit for all versions, located in the bottom part of the barrier body.

Large door at the front for quick and easy access.

Easily removable reinforced gearmotor support.

**Maximum safety:** crush protection in opening and closing; supports inside the barrier body for minimum visual impact.

**Speed adjustable** electronically from 3.5" (Wide M) to 5" (Wide L) for minimum opening time.

**Strength, reliability and ease of installation:** elliptical section bar for lighter weight and resistance to gusts of wind; special profile for quick mounting of accessories.

Optional swivel attachment to safeguard the barrier in the event of impact.

The bar can be mounted on either the right or left side.

**Easy balancing** thanks to a practical spring tension regulator.

**No blackouts:** operation is guaranteed even without mains power, thanks to the PS234 buffer battery for integrated installation in the control unit.

**Release with triangular key** protected from external agents.

## TO OBTAIN A COMPLETE BARRIER RAISING SYSTEM:

1. CHOOSE THE GEARMOTOR

2. ASSOCIATE THE BAR

3. COMPLETE THE SYSTEM WITH OPTIONAL ACCESSORIES

**For bars up to 4 m long**, non-reversible 230 VAC, 24 VDC motor, including anchorage base:

Code	Description
<b>WIDES</b>	Galvanised and orange-painted steel case
<b>WIDESI</b>	With stainless steel case
<b>WIDEM</b>	Galvanised and orange-painted steel case
<b>WIDEMI</b>	With stainless steel case
<b>WIDEMGR1</b>	Galvanised and grey-painted steel case

**For bars up to 6 m long**, non-reversible 230 VAC, 24 VDC motor, including anchorage base:

Code	Description
<b>WIDEL</b>	Galvanised and orange-painted steel case
<b>WIDELI</b>	With stainless steel case
<b>WIDELGR1</b>	Galvanised and grey-painted steel case

## COMMON ACCESSORIES

Code	Description	Pcs. Pack
<b>WIA20</b>	Control units	1
<b>XBA13</b>	Bumper rubber, 1 m	9
<b>WA10</b>	Red reflective adhesive strip	24
<b>WA11</b>	Adjustable support for bars	1
<b>WA13</b>	Aluminium rack, 2 m	1
<b>PSS324</b>	24 V battery with integrated battery charger	1

## ACCESSORIES FOR WIDE S

Code	Description	Pcs. Pack
<b>XBA19</b>	White painted aluminium bar 45x58x4270 mm	1
<b>XBA4</b>	Plug-in signal light for mounting on the top or bottom of the bar. Length 4 m	1
<b>WIA10</b>	Swivel attachment	1
<b>SIA1</b>	Anchorage base with clamps	1

## ACCESSORIES FOR WIDE M

Code	Description	Pcs. Pack
<b>XBA19</b>	White painted aluminium bar 45x58x4270 mm	1
<b>XBA4</b>	Plug-in signal light for mounting on the top or bottom of the bar. Length 4 m	1
<b>WIA10</b>	Swivel attachment	1
<b>SIA1</b>	Anchorage base with clamps	1
<b>WA12</b>	Movable support for bars, reinforced and resistant	1
<b>WA11</b>	Bar joint Wide M	1

## ACCESSORIES FOR WIDE L

Code	Description	Pcs. Pack
<b>XBA15</b>	White painted aluminium bar 69x92x3150 mm	1
<b>XBA14</b>	White painted aluminium bar 69x92x4150 mm	1
<b>XBA5</b>	White painted aluminium bar 69x92x5150 mm	1
<b>XBA9</b>	Expansion joint	1
<b>XBA6</b>	Plug-in signal light for mounting on the top or bottom of the bar. Length 6 m	1
<b>XBA18</b>	Plug-in signal light for mounting on the top or bottom of the bar. Length 8 m	1
<b>SIA1</b>	Anchorage base with clamps	1
<b>WA12</b>	Movable support for bars, reinforced and resistant	1

Find out more on page → 138.

## TECHNICAL SPECIFICATIONS

Code	WIDES	WIDESI	WIDEM	WIDEMI	WIDEL	WIDELI
<b>ELECTRICAL SPECIFICATIONS</b>						
Power supply (VAC 50/60 Hz)				230		
Power supply (VDC)				24		
Draw (A)	1		1,1		0,6	
Power (W)				300		360
<b>PERFORMANCE DATA</b>						
Speed (S)	4		3,5		5	
Torque (Nm)	100		140		200	
Working cycle (cycles/hour)	100		300		200	
<b>DIMENSIONAL AND GENERAL DATA</b>						
Protection class (IP)				54		
Operating temperature (°C Min/Max)				-20 ÷ +55		
Dimensions (mm)	280x178x1000 h		320x205x1000 h		420x205x1030 h	
Weight (kg)	40		46		54	

## DIMENSIONS

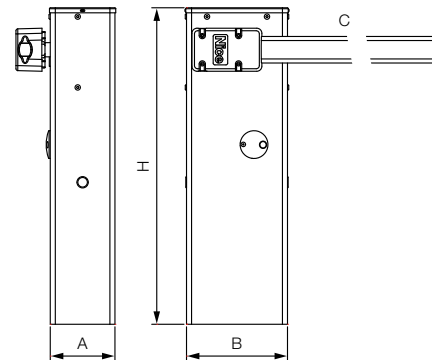

	WIDE S	WIDE M	WIDE L
A	178	208	205
B	280	320	420
C	max. 4 m	max. 4 m	max. 6 m
H	1000	1000	1030

## COLOUR VERSIONS



**ORANGE** RAL2004    **STEEL INOX** AISI 304    **GREY** RAL7015

## COMPATIBILITY WITH CONTROL SYSTEMS AND ACCESSORIES

WIDES / WIDESI / WIDEM / WIDEMI / WIDEL / WIDELI	Control unit/Receiver
	<b>Integrated*</b>
• • •	<b>OXIBD / OXILR</b>
	<b>Transmitter</b>
• • •	<b>ERA INTI</b> - 2 channels, 433.92 MHz, different colours
• • •	<b>ERA ONE / MYGO</b> - 2, 4 or 8 channels, 433.92 MHz
• • •	<b>MYGOBD / ERA ONE LR</b>
• • •	<b>DOMI</b>
	<b>Photocells</b>
• • •	<b>EPS</b> - Slim / <b>EPM</b> - Medium / <b>EPL</b> - Large
• • •	<b>EPSB</b> - Slim, BlueBUS / <b>EPMB</b> - Medium, BlueBUS / <b>EPLB</b> - Large, BlueBUS
• • •	<b>EPMOR</b> - Medium, reflective
• • •	<b>EPMORB</b> - Medium, BlueBUS, reflective
• • •	<b>EPMOW</b> - Medium, wireless self-synchronised
• • •	<b>F210</b> - Synchronised, adjustable / <b>FT210</b> - For sensitive edges
• • •	<b>F210B</b> - BlueBUS
• • •	<b>FT210B</b> - For sensitive edges, BlueBUS
	<b>Flashing light</b>
• • •	<b>ELAC</b>
• • •	<b>ELDC</b>
• • •	<b>WLT</b> - Multifunction LED light

\* Radio receiver not compatible with the O-box functions of the Opera system.

# Accessories for rising arm barrier systems

## BARS AND ACCESSORIES FOR BARS

**New**

			
<b>XBA40</b> Plug-in RG signal lights for mounting on the top or bottom of the bar. 4 m long for M3BAR and M5BAR. Pcs./pack 1	<b>XBA60</b> Plug-in RG signal lights for mounting on the top or bottom of the bar. 6 m long for M5BAR and M7BAR. Pcs./pack 1	<b>XBA80</b> Plug-in RG signal lights for mounting on the top or bottom of the bar. 8 m long for M7BAR and LBAR. Pcs./pack 1	<b>XBA13T</b> Transparent bumper rubber, 1 m. Pcs./pack 9

				
<b>XBA4</b> Plug-in signal lights for mounting on the top or bottom of the bar. 4 m long for S4BAR, M3BAR, M5BAR, WIDES and WIDEM. Pcs./pack 1	<b>XBA6</b> Plug-in signal lights for mounting on the top or bottom of the bar. 6 m long for M5BAR, M7BAR, WIDEL. Pcs./pack 1	<b>XBA18</b> Plug-in signal lights for mounting on the top or bottom of the bar. 8 m long for M7BAR, LBAR, WIDEL. Pcs./pack 1	<b>XBA8</b> Traffic light for integrated installation in cover for MBAR and LBAR. Pcs./pack 1	<b>XBA7</b> Flashing light for integrated installation in cover for SBAR, MBAR and LBAR. Pcs./pack 1

								
<b>XBA19</b> White painted aluminium bar 45x58x4270 mm for S4BAR, WIDES and WIDEM. Pcs./pack 1	<b>XBA15</b> White painted aluminium bar 69x92x3150 mm for M3BAR, M7BAR, LBAR and WIDEL. Pcs./pack 1	<b>XBA14</b> White painted aluminium bar 69x92x4150 mm for M5BAR, M7BAR, LBAR, WIDEL. Pcs./pack 1	<b>XBA5</b> White painted aluminium bar 69x92x5150 mm for M5BAR, M7BAR, LBAR, WIDEL. Pcs./pack 1	<b>XBA9</b> Expansion joint for M3BAR, M7BAR, LBAR, WIDEM and WIDEL. Pcs./pack 1	<b>XBA13</b> Bumper rubber, 1 m. Pcs./pack 9	<b>WA10</b> Red reflective adhesive strips. Pcs./pack 24	<b>WA11</b> Adjustable support for bars. Pcs./pack 1	<b>WA12</b> Movable support for bars, reinforced and resistant. Pcs./pack 1

						
<b>WA13</b> 2 m aluminium rack for M3BAR, M5BAR, LBAR and WIDE. Pcs./pack 1	<b>XBA10</b> Swivel attachment for bars up to 4 m long for M3BAR and M5BAR. Pcs./pack 1	<b>WIA10</b> Swivel attachment for WIDES and WIDEM. Pcs./pack 1	<b>XBA11</b> Joint for bars (1950 mm to 2400 mm) for M3BAR, M5BAR and WIDEM. Pcs./pack 1	<b>WIA11</b> Bar joint for WIDEM. Pcs./pack 1	<b>LP21</b> 1-channel magnetic loop detector for MBAR and LBAR. Pcs./pack 1	<b>LP22</b> 2-channel magnetic loop detector for MBAR and LBAR. Pcs./pack 1

## ANCHORAGE BASE



**SIA1**  
Anchorage base with  
clamps for SBAR, WIDES  
and WIDEM.

Pcs./pack 1



**SIA2**  
Anchorage base with  
clamps for WIDEL.

Pcs./pack 1



**XBA16**  
Base di ancoraggio con  
zanche per MBAR.

Pz./Conf. 1



**XBA17**  
Anchorage base with  
clamps for LBAR.

Pcs./pack 1

## SPARE CONTROL UNITS



**SPXBA20R30**  
Spare control unit for  
S4BAR.

Pcs./pack 1



**BCU1**  
Spare control unit for  
MBAR and LBAR.

Pcs./pack 1



**WIA20**  
Spare control unit for  
WIDE.

Pcs./pack 1

## ACCESSORIES FOR 24V



**PSS124**  
24 V battery with inte-  
grated battery charger for  
SBAR.

Pcs./pack 1



**PS224**  
24 VDC buffer battery for  
MBAR and LBAR.

Pcs./pack 1



**PSS324**  
24 V battery with inte-  
grated battery charger  
for WIDE.

Pcs./pack 1



**SYKCE30**  
Kit di alimentazione solare composto dal pannello  
fotovoltaico SYP30, dal Box batteria PSY24 con  
circuito di controllo della carica e alimentatore SYA1

Pz./Conf. 1

Solemyo

24V

Nice

## Standard installation diagram for barrier raising systems

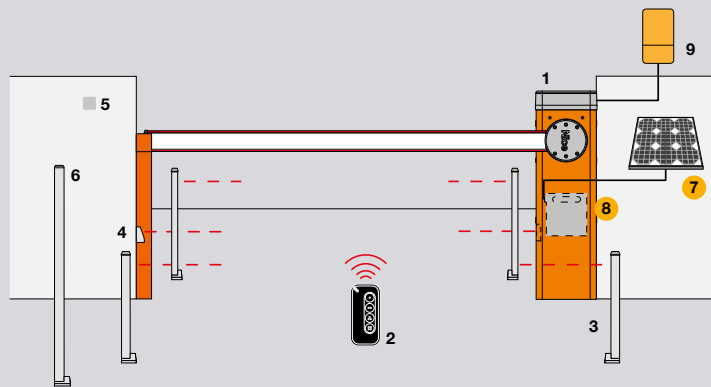

### S-BAR

1. Motor 2. Transmitter 3. Post-mounted photocells 4. Photocells 5. Digital or key switch 6. Post-mounted digital or key switch 7. SYP30 solar panel 8. PSY24 battery box 9. Pro-View multifunction interface

● Solemyo solar power accessories

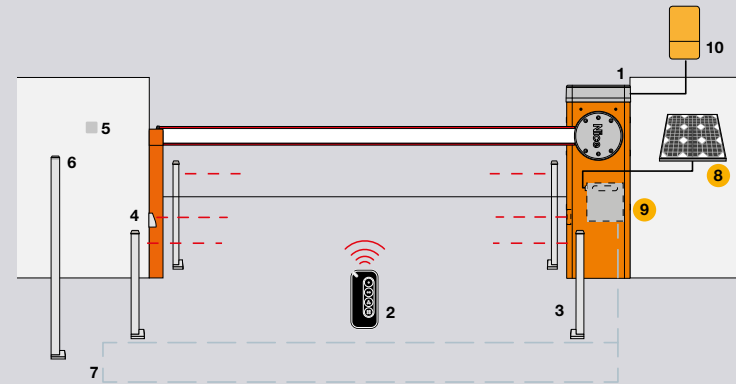

### M-BAR

1. Motor 2. Transmitter 3. Post-mounted photocells 4. Photocells 5. Digital or key switch 6. Post-mounted digital or key switch 7. Loop detector 8. SYP30 solar panel 9. PSY24 battery box 10. Pro-View multifunction interface

● Solemyo solar power accessories

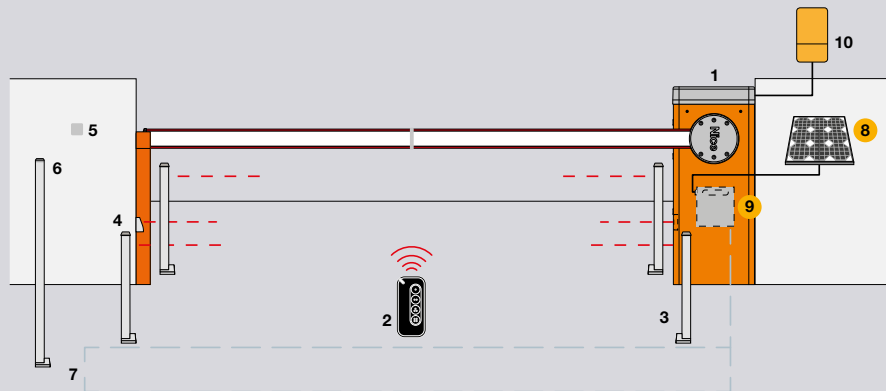

### L-BAR

1. Motor 2. Transmitter 3. Post-mounted photocells 4. Photocells 5. Digital or key switch 6. Post-mounted digital or key switch 7. Loop detector 8. SYP30 solar panel 9. PSY24 battery box 10. Pro-View multifunction interface

● Solemyo solar power accessories

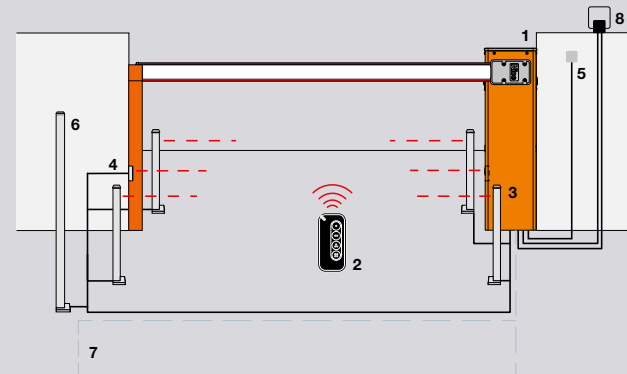

### WIDE SYSTEM

1. Motor 2. Transmitter 3. Post-mounted photocells 4. Photocells 5. Digital or key switch 6. Post-mounted digital or key switch 7. Loop detector 8. Flashing light



Nice

# Selection guide

For sectional and up-and-over doors, in kit

1200 N gearmotor with integrated control unit and integrated receiver. Bidirectional, compatible with Solemyo and Opera.

**Spider 1200BLW**  
pages 146

for sectional doors up to 16.9 m<sup>2</sup>  
for up-and-over doors up to 19.5 m<sup>2</sup>

belt drive

complete with track  
in 1 x 3.2 m section  
complete with track  
in 2 x 1.6 m sections

**SPIDERBL32BDWKCE**

**SPIDERBL16BDWKCE**

800 N gearmotor with integrated control unit and integrated receiver. Bidirectional, compatible with Solemyo and Opera.

**Spider 800/800W**  
pages 148

for sectional doors up to 11.4 m<sup>2</sup>  
for up-and-over doors up to 12.6 m<sup>2</sup>

belt drive

complete with track  
in 1 x 3.2 m section  
complete with track  
in 2 x 1.6 m sections  
complete with track  
in 1 x 3.2 m section  
complete with track  
in 1 x 3.2 m + 1 x 0.8 m sections  
complete with track  
in 2 x 1.6 m sections

with built-in  
Wi-Fi

**SPIDER32BDWKCE**

**SPIDER16BDWKCE**

**SPIDER32BDKCE**

**SPIDER40BDKCE**

**SPIDER16BDKCE**

1000 N gearmotor with integrated control unit and receiver. Compatible with Solemyo and Opera.

**Spido1000**  
pag. 150

for sectional doors up to 12,7 m<sup>2</sup> for  
up-and-over doors up to 13,8 m<sup>2</sup>

belt drive

complete with track in 1 x 3.2 m section  
complete with track in 2 x 1.6 m sections  
complete with track in 1 x 3.2 m + 1 x 0.8 m  
sections

**SPO1032BKCE**

**SPO1016BKCE**

**SPO1040BKCE**

chain drive

complete with track in 1 x 3.2 m section

**SPO1032CKCE**

600N gearmotor with integrated control unit and receiver. Compatible with Solemyo and Opera.

**Spido600**  
pag. 152

for sectional doors up to 9.6 m<sup>2</sup>  
and up-and-over doors up to 10.5 m<sup>2</sup>

belt drive

complete with track in 1 x 3.2 m section  
complete with track in 2 x 1.6 m sections

**SPIDO32BKCE**

**SPIDO16BKCE**

chain drive

complete with track in 1 x 3.2 m section  
complete with track in 2 x 1.6 m sections

**SPIDO32CKCE**

**SPIDO16CKCE**



**For sectional and up-and-over doors, also available in kit with bidirectional technology**

Irreversible, 24 Vdc,  
with built-in control unit,  
transmission with rack  
on the rail.  
**Spykit HS**  
pages 44

**Spykit, Spykit BD**  
pages 154/157

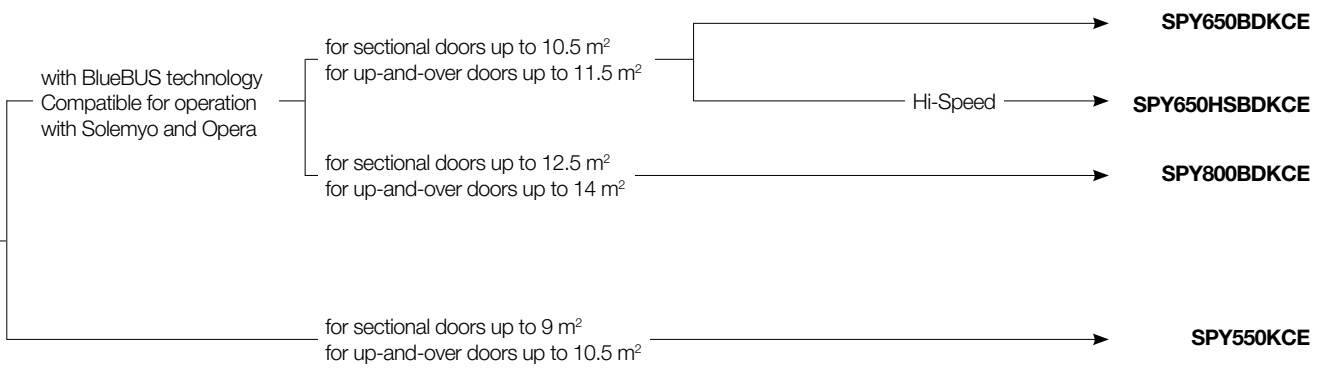

Nice

# Selection guide

For up-and-over doors, also available in a kit

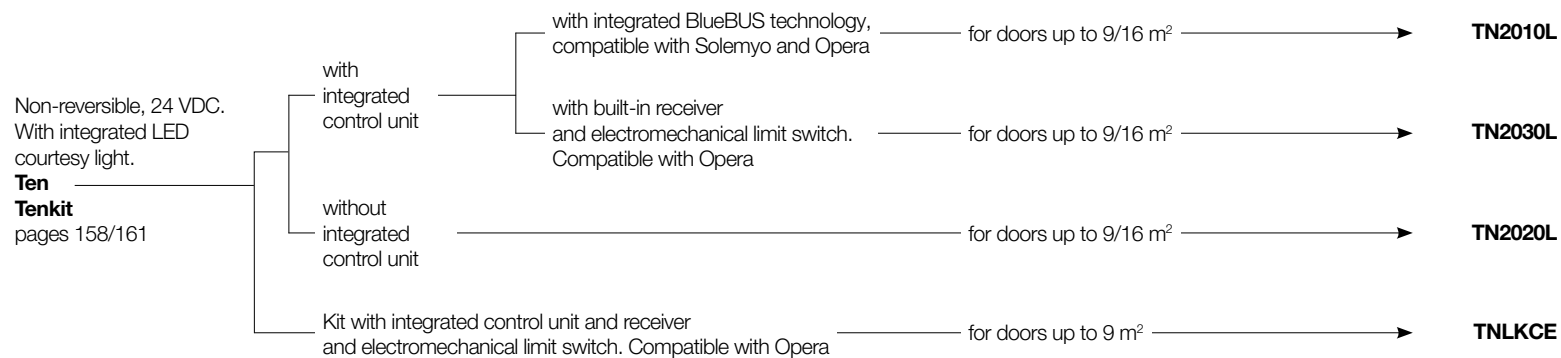

For sectional doors, for industrial and commercial use

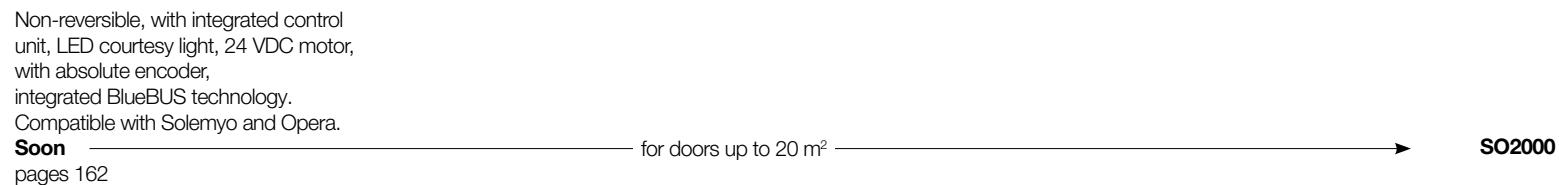

**For sectional doors and two-leaf sliding doors for industrial and commercial use**

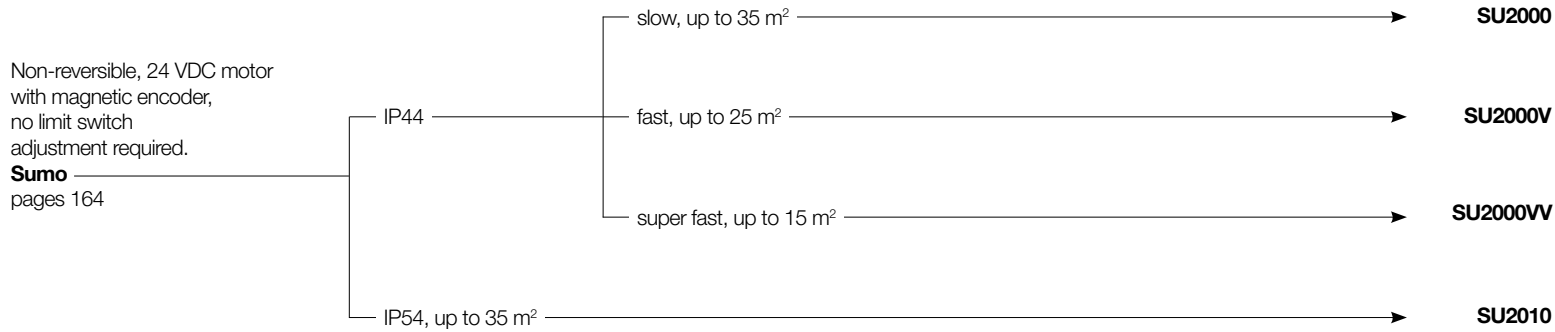

**For two-leaf folding doors**

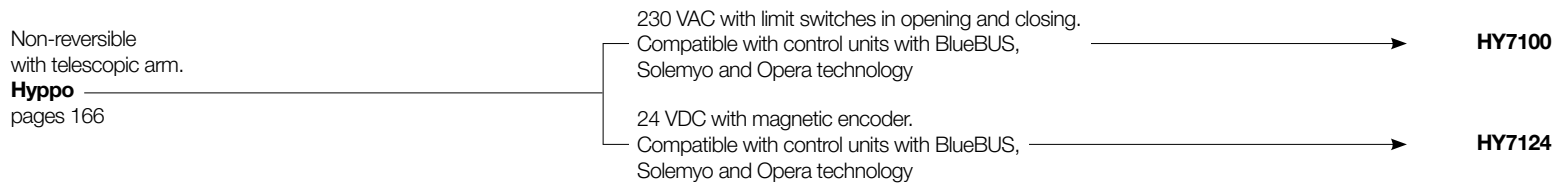

Nice

# Spider 1200BLW

For sectional doors up to 16.9 m<sup>2</sup> and up-and-over doors up to 19.5 m<sup>2</sup>.



Available in a KIT

Motor head bottom plate  
in metal, 100% robust-  
ness guaranteed



NICE GREEN  
INNOVATION

EPD<sup>®</sup>

IES-0011928

BlueBus

24V

BiDi

Yubii

Solemyo

Opera

Programmable via  
App

With Pro-View or  
BiDi-WiFi & MyNice  
Pro App.



New 1200N gearmotor with brushless motor and built-in Wi-Fi.

Equipped with built-in control unit and integrated bidirectional receiver. Garage door remote controlled in conjunction with gate automations thanks to built-in Wi-Fi technology. Control via MyNice app.

Spider can also be integrated into the Yubii eco-system for use with third-party devices. Control via Yubii app.

Various kits to choose from, combining belt or chain drive system with track type (4 m - 3.2 m or 2 x 1.6 m).

## Performance

Designed for **intensive use thanks to the new brushless motor** (up to 150 cycles per day).

Expandable control unit with accessory modules to increase the number of inputs or outputs.

## Connectivity

Always connected thanks to the new built-in Wi-Fi module. Allows you to control, manage, check and know everything about the garage door automation anytime and anywhere via your smartphone.

Can be programmed via the Pro-View multi-function interface or the MyNice Pro app, which includes a simple wizard.

## Sustainability

The integrated standby power module guarantees 90% lower energy consumption when the product is in standby\*.

**Spider1200 has obtained environmental product certification**, a fundamental requirement for Green Public Contracts and Green Building Plans.

**Energy consumption falls by up to 20% thanks to the new brushless motor\*\*.**

Designed with sustainability in mind.

## Safety

**Anti-intrusion function:** if a break-in attempt is detected, a notification will be received via the MyNice app and a new closing manoeuvre will be automatically forced\*\*\*.

**Eye Check, visual check system:** green and red LED lights built into the motor signal potential issues/need for maintenance or show that everything is working smoothly.

\* Calculated by comparing the standby consumption of an operator with the Standby module ("All" mode active) and without it.

\*\* Calculated by comparing the energy consumption of Spider1200BLW with the equivalent model without brushless motor.

\*\*\* The function activates one minute after closing the door.

Code	Description
<b>SPIDERBL32BDWKCE</b>	Kit for automating sectional and up-and-over doors, 1200N, with brushless motor, built-in Wi-Fi, control unit and bidirectional receiver. The kit contains: SPIDER-1200BLW, 2 x MYGO4, 1 x SR32B, 1 x MLAE22
<b>SPIDERBL16BDWKCE</b>	Kit for automating sectional and up-and-over doors, 1200N, with brushless motor, built-in Wi-Fi, control unit and bidirectional receiver. The kit contains: SPIDER-1200BLW, 2 x MYGO4, 1 x SR16B, 1 x MLAE22

#### The SPIDERBL32BDWKCE kit contains:

Code	Description	Quantity
<b>SPIDER1200BLW</b>	Gearmotor with brushless motor and built-in Wi-Fi, control unit and bidirectional receiver	1
<b>MYGO4</b>	4-channel 433.92 MHz transmitter	2
<b>SR32B</b>	Track length 1 x 3.2 m piece, belt drive	1
<b>MLAE22</b>	Expansion board for modular control unit, 2I/2O	1

#### The SPIDERBL16BDWKCE kit contains:

Code	Description	Quantity
<b>SPIDER1200BLW</b>	Gearmotor with brushless motor and built-in Wi-Fi, control unit and bidirectional receiver	1
<b>MYGO4</b>	4-channel 433.92 MHz transmitter	2
<b>SR16B</b>	Track length 2 x 1.6 m pieces, belt drive	1
<b>MLAE22</b>	Expansion board for modular control unit, 2I/2O	1

#### COMMON ACCESSORIES

Code	Description	Pcs. Pack
<b>SPMCU2R30</b>	Spare control unit for SPIDER1200BLW	1
<b>PSS124</b>	24 V battery with integrated battery charger	1
<b>MLAE21</b>	Plug-in expansion board 1 Output 2 Input	1
<b>MLAE22</b>	Plug-in expansion board 2 Output (1 230V Relay) 2 Input	1
<b>MLAE44</b>	Plug-in expansion board 4 Output 4 Input	1
<b>KI1</b>	Kit for release from outside with metal pull-cord and key ratchet	1
<b>SPA2</b>	Kit for release from outside with metal pull-cord	1
<b>SPA5</b>	Swing arm sliding on bearings, optimised for projecting up-and-over doors	1
<b>SPA6</b>	Enlarged connecting arm, 585 mm long	1
<b>SPA7</b>	Kit with two additional fixing brackets	2
<b>SRA1</b>	Quick-connect brackets for ceiling mounting	6
<b>SYKCE30</b>	Solar power supply kit consisting of SYP30 photovoltaic panel and PSY24 battery box with charging control circuit	1
<b>TS</b>	Sign	1

N.B. The contents of the pack may vary: always consult the dealer.

#### TECHNICAL SPECIFICATIONS

Code	SPIDER1200BLW
------	---------------

#### ELECTRICAL SPECIFICATIONS

Power supply (VAC 50/60 Hz)	230
Draw (A)	1.5
Power (W)	240
Power in standby (W)	1.5

#### PERFORMANCE DATA

Speed (m/s)	0.16
Force (N)	1200
Working cycle (cycles/day)	150

#### DIMENSIONAL AND GENERAL DATA

Protection class (IP)	IP40
Operating temperature (°C Min/Max)	-20°C - +55°C
Dimensions (mm)	225x395x105.5 h
Weight (kg)	6.7

#### OPERATING LIMITS

	Non-protruding up-and-over doors (with SPA5)		Protruding up-and-over doors (with SPA5) or with springs (without SPA5)		Sectional doors	
	W	H	W	H	W	H
<b>SR32/16</b>	6.5 m	2.4 m	6.5 m	3 m	6.5 m	2.6 m
<b>SR40*</b>	4.9 m	3.4 m	5.6 m	3.6 m	5 m	3.4 m

Using maximum travel  
\*Also valid for SR32/16 + SR08

#### DIMENSIONS

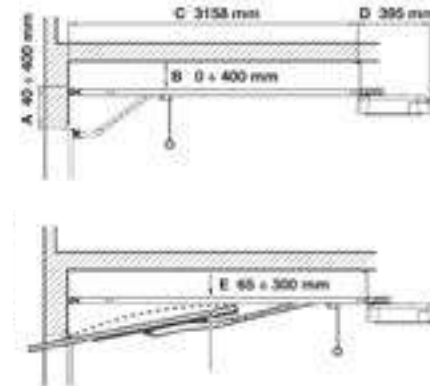

#### TRACK TECHNICAL SPECIFICATIONS

Code	SR32B	SR16B	SR40B
Track type	1 galvanised steel section	2 galvanised steel sections	1 piece in galvanised steel + extension
Track length installed (mm)	3200	3200 (1600x2)	3200+800
Useful travel (mm)	2800	2800	3500*
Weight (kg)	6.5	7	8.3
Pack dimensions (mm)	3300x90x45 h	1690x165x45	3300x90x45 h

\*For use with 3.2 m track to obtain overall 4 m length.

\*\*Reference to 4 m track

#### COMPATIBILITY WITH CONTROL SYSTEMS AND ACCESSORIES

SPIDER1200BLW

#### Control unit/Receiver

- Integrated\*
- OXIBD / OXILR

#### Transmitters

- ERA INTI - 2 channels, 433.92 MHz, different colours
- ERA ONE / MYGO - 2, 4 or 8 channels, 433.92 MHz
- MYGOBD / ERA ONE BD / ERA ONE LR
- DOMI

#### Photocells

- EPS - Slim / EPM - Medium / EPL - Large
- EPSB - Slim, BlueBUS / EPMB - Medium, BlueBUS / EPLB - Large, BlueBUS
- EPMOR - Medium, reflective
- EPMORB - Medium, BlueBUS, reflective
- EPMOW - Medium, wireless, self-synchronised
- F210 synchronised, adjustable / FT210 for sensitive edges
- F210B BlueBus / FT210B for sensitive edges, BlueBus

#### Flashing light

#### ELAC

- ELDC
- WLT - Multifunction LED light

\* Radio receiver not compatible with the O-box functions of the Opera system.

Nice

# Spider 800/800W

For sectional doors up to 11.4 m<sup>2</sup> and up-and-over doors up to 12.6 m<sup>2</sup>.



Available in a KIT

Motor head bottom plate in metal, 100% robustness guaranteed



3 cm track height

New unlocking system

LED lights



NICE GREEN INNOVATION

EPD<sup>®</sup>

IES-0011928

BlueBus

24V

BiDi

Yubii

Solemyo

Opera

Programmable via App

With Pro-View or BiDi-WiFi & MyNice Pro App.



New 800N gearmotor with built-in Wi-Fi (also available without Wi-Fi).

Equipped with built-in control unit and integrated bidirectional receiver. Garage door remote controlled in conjunction with gate automations thanks to built-in Wi-Fi technology. Control via MyNice app.

Spider can also be integrated into the Yubii ecosystem for use with third-party devices. Control via Yubii app.

Various kits to choose from, combining belt or chain drive system with track type (4 m - 3.2 m or 2 x 1.6 m).

## Connectivity

Always connected thanks to the new **built-in Wi-Fi module**. Allows you to control, manage, check and know everything about the garage door automation anytime and anywhere via your smartphone.

Can be programmed via the Pro-View multi-function interface or the MyNice Pro app, which includes a simple wizard.

## Sustainability

The integrated standby power module guarantees 90% lower energy consumption when the product is in standby\* (0.3W).

**Spider800 has obtained environmental product certification**, a fundamental requirement for Green Public Contracts and Green Building Plans.

Designed with sustainability in mind.

## Safety

**Anti-intrusion function:** if a break-in attempt is detected, a notification will be received via the MyNice app and a new closing manoeuvre will be automatically forced\*\*.

**Eye Check, visual check system:** green and red LED lights built into the motor signal potential issues/need for maintenance or show that everything is working smoothly.

\* Calculated by comparing the standby consumption of an operator with the Standby module ("All" mode active) and without it.

\*\* The function activates one minute after closing the door.

Code	Description
<b>SPIDER32BDWKCE</b>	Kit for automating sectional and up-and-over doors, 800N, built-in Wi-Fi, integrated control unit and bidirectional receiver. The kit contains SPIDER800W, 2 x MYGO4, 1 x SR32B.
<b>SPIDER16BDWKCE</b>	Kit for automating sectional and up-and-over doors, 800N, built-in Wi-Fi, integrated control unit and bidirectional receiver. The kit contains: SPIDER800W, 2 x MYGO4, 1 x SR16B
<b>SPIDER32BDKCE</b>	Kit for automating sectional and up-and-over doors, 800N, integrated control unit and bidirectional receiver. The kit contains: SPIDER800, 2 x MYGO4, 1 x SR32B
<b>SPIDER40BDKCE</b>	Kit for automating sectional and up-and-over doors, 800N, integrated control unit and bidirectional receiver. The kit contains: SPIDER800, 2 x MYGO4, 1 x SR40B
<b>SPIDER16BDKCE</b>	Kit for automating sectional and up-and-over doors, 800N, integrated control unit and bidirectional receiver. The kit contains: SPIDER800, 2 x MYGO4, 1 x SR40B

**The SPIDER32BDWKCE kit contains:**

Code	Description	Quantity
<b>SPIDER800W</b>	Gearmotor with built-in Wi-Fi, control unit and bidirectional receiver	1
<b>MYGO4</b>	4-channel 433.92 MHz transmitter	2
<b>SR32B</b>	Track length 1 x 3.2 m piece, belt drive	1

**The SPIDER16BDWKCE kit contains:**

Code	Description	Quantity
<b>SPIDER800W</b>	Gearmotor with built-in Wi-Fi, control unit and bidirectional receiver	1
<b>MYGO4</b>	4-channel 433.92 MHz transmitter	2
<b>SR16B</b>	Track length 2 x 1.6 m pieces, belt drive	1

**The SPIDER32BDKCE kit contains:**

Code	Description	Quantity
<b>SPIDER800</b>	Gearmotor with integrated control unit and bidirectional receiver	1
<b>MYGO4</b>	4-channel 433.92 MHz transmitter	2
<b>SR32B</b>	Track length 1 x 3.2 m piece, belt drive	1

**The SPIDER40BDKCE kit contains:**

Code	Description	Quantity
<b>SPIDER800</b>	Gearmotor with integrated control unit and bidirectional receiver	1
<b>MYGO4</b>	4-channel 433.92 MHz transmitter	2
<b>SR40B</b>	Track length 1 x 3.2 m piece + 1 x 0.8 m piece, belt drive	1

**The SPIDER16BDKCE kit contains:**

Code	Description	Quantity
<b>SPIDER800</b>	Gearmotor with integrated control unit and bidirectional receiver	1
<b>MYGO4</b>	4-channel 433.92 MHz transmitter	2
<b>SR16B</b>	Track length 2 x 1.6 m pieces, belt drive	1

N.B. The contents of the pack may vary: always consult the dealer.

**COMMON ACCESSORIES**

Code	Description	Pcs. Pack
<b>SPMCU1R30</b>	Spare control unit for SPIDER800	1
<b>SPMCU2R30</b>	Spare control unit for SPIDER800W	1
<b>MLAE21</b>	Plug-in expansion board 1 Output 2 Input	1
<b>MLAE22</b>	Plug-in expansion board 2 Output (1 230V Relay) 2 Input	1
<b>MLAE44</b>	Plug-in expansion board 4 Output 4 Input	1
<b>PSS124</b>	24 V battery with integrated battery charger	1
<b>KI1</b>	Kit for release from outside with metal pull-cord and key ratchet	1
<b>SPA2</b>	Kit for release from outside with metal pull-cord	1
<b>SPA5</b>	Swing arm sliding on bearings, optimised for projecting up-and-over doors	1
<b>SPA6</b>	Enlarged connecting arm, 585 mm long	1
<b>SPA7</b>	Kit with two additional fixing brackets	2
<b>SRA1</b>	Quick-connect brackets for ceiling mounting	6
<b>SYKCE30</b>	Solar power supply kit consisting of SYP30 photovoltaic panel and PSY24 battery box with charging control circuit	1
<b>TS</b>	Sign	1

**TECHNICAL SPECIFICATIONS**

Code	SPIDER800W/ SPIDER800
<b>ELECTRICAL SPECIFICATIONS</b>	
Power supply (VAC 50/60 Hz)	230
Draw (A)	1.1
Power (W)	180
Power in standby (W)	(0.3) 1.5*
<b>PERFORMANCE DATA</b>	
Speed (m/s)	0.2
Force (N)	800
Working cycle (cycles/day)	50
<b>DIMENSIONAL AND GENERAL DATA</b>	
Protection class (IP)	IP40
Operating temperature (°C Min/Max)	-20°C - +55°C
Dimensions (mm)	225x395x105.5 h
Weight (kg)	4.9

(\*Spider800W)

**OPERATING LIMITS**

	Non-protruding up-and-over doors (with SPA5)		Protruding up-and-over doors (with SPA5) or with springs (without SPA5)		Sectional doors	
	W	H	W	H	W	H
<b>SR32/16</b>	4.2 m	2.4 m	4.2 m	3 m	4.4 m	2.6 m
<b>SR40*</b>	3.1 m	3.4 m	3.6 m	3.6 m	3.4 m	3.4 m

Using maximum travel  
\*Also valid for SR32/16 + SR08

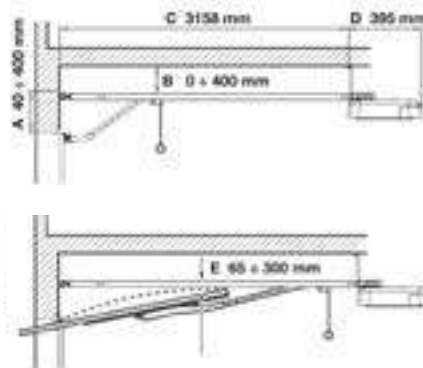
**DIMENSIONS****TRACK TECHNICAL SPECIFICATIONS**

Code	SR32B	SR16B	SR40B
Track type	1 galvanised steel section	2 galvanised steel sections	1 piece in galvanised steel + extension
Track length installed (mm)	3200	3200 (1600x2)	3200+800
Useful travel (mm)	2800	2800	3500*
Weight (kg)	6.5	7	8.3
Pack dimensions (mm)	3300x90x45 h	1690x165x45	3300x90x45 h

\*Reference to 4 m track.

**COMPATIBILITY WITH CONTROL SYSTEMS AND ACCESSORIES**

SPIDER800W/ SPIDER800	Control unit/Receiver
	<ul style="list-style-type: none"> <li>Integrated*</li> </ul>
	<ul style="list-style-type: none"> <li>OXIBD / OXILR</li> </ul>
	Transmitters
	<ul style="list-style-type: none"> <li>ERA INTI - 2 channels, 433.92 MHz, different colours</li> <li>ERA ONE / MYGO - 2, 4 or 8 channels, 433.92 MHz</li> <li>MYGOBD / ERA ONE BD / ERA ONE LR</li> <li>DOMI</li> </ul>
	Photocells
	<ul style="list-style-type: none"> <li>EPS - Slim / EPM - Medium / EPL - Large</li> <li>EPSB - Slim, BlueBUS / EPMB - Medium, BlueBUS / EPLB - Large, BlueBUS</li> <li>EPMOR - Medium, reflective</li> <li>EPMORB - Medium, BlueBUS, reflective</li> <li>EPMOW - Medium, wireless, self-synchronised</li> <li>F210 synchronised, adjustable / FT210 for sensitive edges</li> <li>F210B BlueBus / FT210B for sensitive edges, BlueBus</li> </ul>
	Flashing light
	ELAC
	<ul style="list-style-type: none"> <li>ELDC</li> <li>WLT - Multifunction LED light</li> </ul>

\* Radio receiver not compatible with the O-box functions of the Opera system.

Nice

# Spido 1000 New

For sectional doors up to 12.7 m<sup>2</sup>  
and up-and-over doors up to 13.8 m<sup>2</sup>.



Available in a KIT

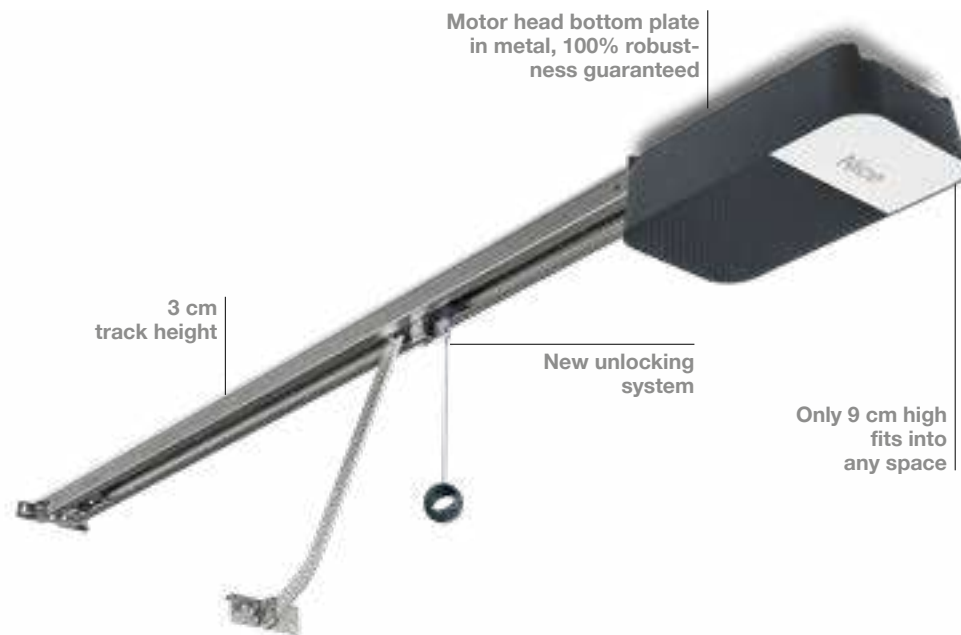

BUS T4

Yubii

Programmable via App

24V

Solemyo

With Pro-View or Bidi-WiFi & MyNice Pro App.

Opera



New 1000N gearmotor with integrated control unit and receiver.

Option to control garage door remotely in conjunction with gate automations. Control via MyNice app.

### Save time during the installation

- **Precise adjustment of limit switches.** No need to install and adjust mechanical limit switches on the track.
- **Quick and easy programming** thanks to the new one-digit display.
- **Safe, functional design**
- **Safe, easy transport:** the new track is now 3 cm high with fully integrated carriage and head. Completely safe to transport.
- **Motor head only 9 cm high** to fit into the smallest spaces.

- **Each access to the** control unit through the user-friendly cover.
- **New unlocking system** for moving the garage door manually in the event of a blackout.

### Performance

Up to 100 cycles per day for 12.7m<sup>2</sup> sectional doors.

Longer usable travel: new track 20 cm longer, ideal for most garage doors on the market.

### Sustainability

Standby energy consumption of 0.3W.

Code	Description
<b>SPO1032BKCE</b>	Kit for automating sectional and up-and-over doors, 1000N, integrated control unit and unidirectional receiver. The kit contains: SPIDO1000, 2 x INTI2, 1 x SR32B
<b>SPO1016BKCE</b>	Kit for automating sectional and up-and-over doors, 1000N, integrated control unit and unidirectional receiver. The kit contains: SPIDO1000, 2 x INTI2, 1 x SR16B
<b>SPO1032CKCE</b>	Kit for automating sectional and up-and-over doors, 1000N, integrated control unit and unidirectional receiver. The kit contains: SPIDO1000, 2 x INTI2, 1 x SR32C
<b>SPO1040BKCE</b>	Kit for automating sectional and up-and-over doors, 1000N, integrated control unit and unidirectional receiver. The kit contains: SPIDO1000, 2 x INTI2, 1 x SR40B.

#### The SPO1032BKCE kit contains:

Code	Description	Quantity
<b>SPIDO1000</b>	Gearmotor with integrated control unit and integrated unidirectional Opera receiver	1
<b>INTI2</b>	Transmitter, 433.92 MHz, 2 channels	2
<b>SR32B</b>	Track length 1 x 3.2 m piece, belt drive	1

#### The SPO1016BKCE kit contains:

Code	Description	Quantity
<b>SPIDO1000</b>	Gearmotor with integrated control unit and integrated unidirectional Opera receiver	1
<b>INTI2</b>	Transmitter, 433.92 MHz, 2 channels	2
<b>SR16B</b>	Track length 2 x 1.6 m pieces, belt drive	1

#### The SPO1032CKCE kit contains:

Code	Description	Quantity
<b>SPIDO1000</b>	Gearmotor with integrated control unit and integrated unidirectional Opera receiver	1
<b>INTI2</b>	Transmitter, 433.92 MHz, 2 channels	2
<b>SR32C</b>	Track length 1 x 3.2 m piece, chain drive	1

#### The SPO1040BKCE kit contains:

Code	Description	Quantity
<b>SPIDO1000</b>	Gearmotor with integrated control unit and integrated unidirectional Opera receiver	1
<b>INTI2</b>	Transmitter, 433.92 MHz, 2 channels	2
<b>SR40B</b>	Track length 1 x 3.2 m piece + 1 x 0.8 m piece, belt drive	1

**N.B.** The contents of the pack may vary: always consult the dealer.

#### COMMON ACCESSORIES

Code	Description	Pcs. Pack
<b>SPSPA1000</b>	Spare control unit for SPIDO1000	1
<b>PSS124</b>	24 V battery with integrated battery charger	1
<b>KI1</b>	Kit for release from outside with metal pull-cord and key ratchet	1
<b>SPA2</b>	Kit for release from outside with metal pull-cord	1
<b>SPA5</b>	Swing arm sliding on bearings, optimised for projecting up-and-over doors	1
<b>SPA6</b>	Enlarged connecting arm, 585 mm long	1
<b>SPA7</b>	Kit with two additional fixing brackets	2
<b>SRA1</b>	Quick-connect brackets for ceiling mounting	6
<b>SYKCE30</b>	Solar power supply kit consisting of SYP30 photovoltaic panel and PSY24 battery box with charging control circuit	1
<b>TS</b>	Sign	1

#### TECHNICAL SPECIFICATIONS

Code	SPIDO1000
<b>ELECTRICAL SPECIFICATIONS</b>	
Power supply (VAC 50/60 Hz)	230
Draw (A)	1.6
Power (W)	300
Power in standby (W)	0.3
<b>PERFORMANCE DATA</b>	
Speed (m/s)	0.16
Force (N)	1000
Working cycle (cycles/day)	100
<b>DIMENSIONAL AND GENERAL DATA</b>	
Protection class (IP)	40
Operating temperature (°C Min/Max)	-20 ÷ +55
Dimensions (mm)	192x344x90 h
Weight (kg)	4.5 kg

#### OPERATING LIMITS

	Sectional doors		Non-protruding up-and-over doors (with SPA5)		Protruding up-and-over doors (with SPA5) or with springs (without SPA5)	
	L	H	L	H	L	H
<b>SR32/16</b>	4.9 m	2.6 m	4.5 m	2.4 m	4.6 m	3 m
<b>SR40*</b>	3.9 m	3.4 m	3.4 m	3.4 m	3.8 m	3.6 m

Using maximum travel  
\*Also valid for SR32/16 + SR08

#### DIMENSIONS

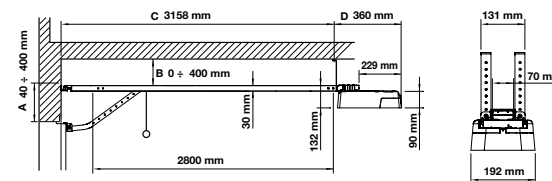

#### TRACK TECHNICAL SPECIFICATIONS

Code	SR32B/C	SR16B/C	SR08/C	SR40B
Track type	1 galvanised steel section	2 galvanised steel sections	Galvanised steel extension	1 piece in galvanised steel + extension
Track length installed (mm)	3200	3200 (1600x2)	800*	3200+800
Useful travel (mm)	2800	2800	3500**	3500**
Weight (kg)	6.5	7	2.6	8.3
Pack dimensions (mm)	3300x90x45	1690x165x45	818x114x85	3300x90x45

\*For use with 3.2 m track to obtain overall 4 m length.

\*\*Reference to 4 m track.

#### COMPATIBILITY WITH CONTROL SYSTEMS AND ACCESSORIES

SPIDO1000

##### Control unit/Receiver

- **Integrated\***

##### OXIBD / OXILR

##### Transmitters

- **ERA INTI** - 2 channels, 433.92 MHz, different colours
- **ERA ONE / MYGO** - 2, 4 or 8 channels, 433.92 MHz

##### MYGOBD / ERA ONE LR

##### DOMI

##### Photocells

- **EPS** - Slim / **EPM** - Medium / **EPL** - Large
- **EPSB** - Slim, BlueBus / **EPMB** - Medium, BlueBus / **EPLB** - Large, BlueBus
- **EPMOR** - Medium, reflective
- **EPMORB** - Medium, BlueBus, reflective
- **EPMOW** - Medium, wireless, self-synchronised

- **F210** synchronised, adjustable / **FT210** for sensitive edges

**F210B** BlueBus / **FT210B** for sensitive edges, BlueBus

##### Lampeggianti

##### ELAC

- **ELDC**
- **WLT** - Multifunction LED light

\* Radio receiver not compatible with the O-box functions of the Opera system.

Nice

# Spido 600

For sectional doors up to 9.6 m<sup>2</sup>  
and up-and-over doors up to 10.5 m<sup>2</sup>.



Available in a KIT

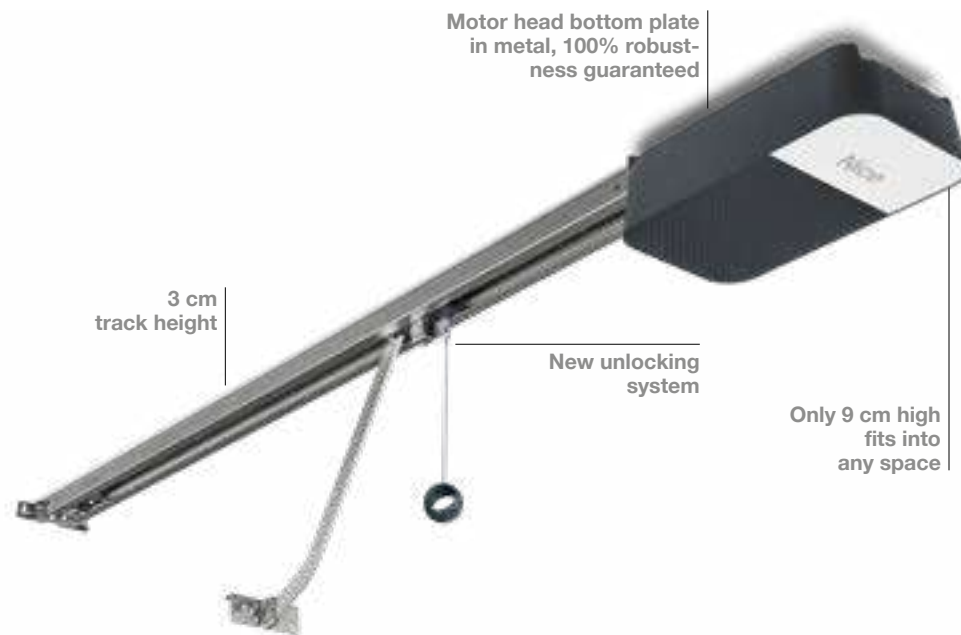

New 600N gearmotor with integrated control unit and receiver.

Option to control garage door remotely in conjunction with gate automations. Control via MyNice app.

Various kits to choose from, combining belt or chain drive system with track type (4 m - 3.2 m or 2 x 1.6 m).

### Save time during the installation

- **Precise adjustment of limit switches.** No need to install and adjust mechanical limit switches on the track.
- **Quick and easy programming** thanks to the new one-digit display.
- **Safe, functional design**

- **Safe, easy transport:** the new track is now 3 cm high with fully integrated carriage and head. Completely safe to transport.
- **Motor head only 9 cm high** to fit into the smallest spaces.
- **Each access to the** control unit through the user-friendly cover.
- **New unlocking system** for moving the garage door manually in the event of a blackout.

### Performance

Open your garage door in just 10 seconds\*\*. Longer usable travel: new track 20 cm longer, ideal for most garage doors on the market.

### Sustainability

Standby energy consumption of 0.3W.

\*\*In a standard installation with 2.25 m high balanced door, excluding acceleration and deceleration.

BUS T4

Yubii

Programmable via App

24V

Solemyo

With Pro-View or Bidi-WiFi & MyNice Pro App.

Opera



Code	Description
<b>SPIDO32BKCE</b>	Kit for automating sectional and up-and-over doors, 600N, integrated control unit and unidirectional receiver. The kit contains: SPIDO600, 2 x INTI2, 1 x SR32B
<b>SPIDO16BKCE</b>	Kit for automating sectional and up-and-over doors, 600N, integrated control unit and unidirectional receiver. The kit contains: SPIDO600, 2 x INTI2, 1 x SR16B
<b>SPIDO32CKCE</b>	Kit for automating sectional and up-and-over doors, 600N, integrated control unit and unidirectional receiver. The kit contains: SPIDO600, 2 x INTI2, 1 x SR32C
<b>SPIDO16CKCE</b>	Kit for automating sectional and up-and-over doors, 600N, integrated control unit and unidirectional receiver. The kit contains: SPIDO600, 2 x INTI2, 1 x SR16C



#### The SPIDO32BKCE kit contains:

Code	Description	Quantity
<b>SPIDO600</b>	Gearmotor with integrated control unit and integrated unidirectional Opera receiver	1
<b>INTI2</b>	Transmitter, 433.92 MHz, 2 channels	2
<b>SR32B</b>	Track length 1 x 3.2 m piece, belt drive	1



#### The SPIDO16BKCE kit contains:

Code	Description	Quantity
<b>SPIDO600</b>	Gearmotor with integrated control unit and integrated unidirectional Opera receiver	1
<b>INTI2</b>	Transmitter, 433.92 MHz, 2 channels	2
<b>SR16B</b>	Track length 2 x 1.6 m pieces, belt drive	1



#### The SPIDO32CKCE kit contains:

Code	Description	Quantity
<b>SPIDO600</b>	Gearmotor with integrated control unit and integrated unidirectional Opera receiver	1
<b>INTI2</b>	Transmitter, 433.92 MHz, 2 channels	2
<b>SR32C</b>	Track length 1 x 3.2 m piece, chain drive	1



#### The SPIDO16CKCE kit contains:

Code	Description	Quantity
<b>SPIDO600</b>	Gearmotor with integrated control unit and integrated unidirectional Opera receiver	1
<b>INTI2</b>	Transmitter, 433.92 MHz, 2 channels	2
<b>SR16C</b>	Track length 2 x 1.6 m pieces, chain drive	1

N.B. The contents of the pack may vary: always consult the dealer.

#### COMMON ACCESSORIES

Code	Description	Pcs. Pack
<b>SPSPA600R30</b>	Spare control unit for SPIDO32BKCE, SPIDO32CKCE, SPIDO16BKCE, SPIDO16CKCE	1
<b>PSS124</b>	24 V battery with integrated battery charger	1
<b>KI1</b>	Kit for release from outside with metal pull-cord and key ratchet	1
<b>SPA2</b>	Kit for release from outside with metal pull-cord	1
<b>SPA5</b>	Swing arm sliding on bearings, optimised for projecting up-and-over doors	1
<b>SPA6</b>	Enlarged connecting arm, 585 mm long	1
<b>SPA7</b>	Kit with two additional fixing brackets	2
<b>SRA1</b>	Quick-connect brackets for ceiling mounting	6
<b>SYKCE30</b>	Solar power supply kit consisting of SYP30 photovoltaic panel and PSY24 battery box with charging control circuit	1
<b>TS</b>	Sign	1

Find out more on page → 174.

#### TECHNICAL SPECIFICATIONS

Code	SPIDO600
<b>ELECTRICAL SPECIFICATIONS</b>	
Power supply (VAC 50/60 Hz)	230
Draw (A)	1
Power (W)	150
<b>PERFORMANCE DATA</b>	
Maximum speed (m/s)	0,2
Maximum force (N)	600
Working cycle (cycles/day)	40
<b>DIMENSIONAL AND GENERAL DATA</b>	
Protection class (IP)	40
Operating temperature (°C Min/Max)	-20 ÷ +55
Pack dimensions (mm)	192x344x90 h
Weight (kg)	3.8 kg

#### OPERATING LIMITS

	Sectional doors		Non-protruding up-and-over doors (with SPA5)		Protruding up-and-over doors (with SPA5) or with springs (without SPA5)	
	W	H	W	H	W	H
<b>SR32/16</b>	3,7 m	2,6 m	3,5 m	2,4 m	3,5 m	3 m
<b>SR40*</b>	2,9 m	3,4 m	2,7 m	3,4 m	3 m	3,6 m

Using maximum travel  
\*Also valid for SR32/16 + SR08

#### DIMENSIONS

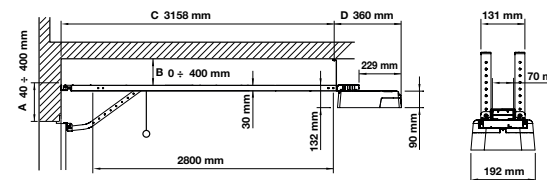

#### TRACK TECHNICAL SPECIFICATIONS

Code	SR32B/C	SR16B/C	SR08/C	SR40B
Track type	1 galvanised steel section	2 galvanised steel sections	Galvanised steel extension	1 galvanised steel section + extension
Track length installed (mm)	3200	3200 (1600x2)	800*	3200+800
Useful travel (mm)	2800	2800	3500**	3500**
Weight (kg)	6,5	7	2,6	8,3
Pack dimensions (mm)	3300x90x45	1690x165x45	818x114x85	3300x90x45

\*For use with 3.2 m track to obtain overall 4 m length.

\*\*Reference to 4 m track

#### COMPATIBILITY WITH CONTROL SYSTEMS AND ACCESSORIES

SPIDO

<b>Control unit/Receiver</b>
• <b>Integrated*</b>
<b>OXIBD / OXILR</b>
<b>Transmitters</b>
• <b>ERA INTI</b> - 2 channels, 433.92 MHz, different colours
• <b>ERA ONE / MYGO</b> - 2, 4 or 8 channels, 433.92 MHz
<b>MYGOBD / ERA ONE LR</b>
<b>DOMI</b>
<b>Photocells</b>
• <b>EPS</b> - Slim / <b>EPM</b> - Medium / <b>EPL</b> - Large
<b>EPSB</b> - Slim, BlueBUS / <b>EPMB</b> - Medium, BlueBUS / <b>EPLB</b> - Large, BlueBUS
• <b>EPMOR</b> - Medium, reflective
<b>EPMORB</b> - Medium, BlueBUS, reflective
<b>EPMOW</b> - Medium, wireless, self-synchronised
• <b>F210</b> synchronised, adjustable / <b>FT210</b> for sensitive edges
<b>F210B</b> BlueBus / <b>FT210B</b> for sensitive edges, BlueBus
<b>Flashing light</b>
<b>ELAC</b>
• <b>ELDC</b>
• <b>WLT</b> - Multifunction LED light

\* Radio receiver not compatible with the O-box functions of the Opera system.

Nice

# Spykit 650/800 BD

For sectional doors up to 10,5 m<sup>2</sup> (SPY650) and 12,5 m<sup>2</sup> (SPY800), up-and-over doors, including canopy doors, up to 11,5 m<sup>2</sup> (SPY650) and 14 m<sup>2</sup> (SPY800).



Available in a KIT



24 Vdc irreversible electromechanical gear motor for residential use, transmission with rack on the rail.

To be combined with SPYRAIL321, SPYRAIL162 and SPYRAIL081 rails.

**Functional and stylish:** the motor is the only component that moves on the track, no chains or other noisy mechanisms. Ideal for any architectural context.

**Handy:** Separate control unit: more practical and convenient for programming and maintenance. Integrated LED courtesy light. Three practical keys to control the automation.

**Quick to install.** A new time-saving solution: the motor power supply module can be easily installed, either on one or the other side of the rail with simple gestures. Limit switches easy to position along the rail with no need to stand and work on the ceiling. No chains or other noisy mechanisms to install.

**Simple to install with the BlueBus system:** requiring just two wires for connection between the control unit and the pairs of photocells and other accessories featuring BlueBus technology.

**Easy to program:** simple and fast basic programming, using the Quick Setup procedure. Simplified advanced programming, using Pro-View.

**ON/OFF release system:** pulling the release knob once releases the motor; pulling it a second time blocks the motor again, in any position along the rail.

**Inexpensive to run and environmentally-friendly:** when connected to the mains in standby mode, the control unit consumes 0,5 W.

**Safe:** obstacle detection, motor power monitoring during travel, diagnostic messages via flashing light and courtesy light.

Adjustable acceleration and deceleration at the start and end of each manoeuvre.

Ready for installation of the latest generation 8,2 kOhm resistive sensitive edges.

**Optimised logistics:** for practical management and transport, the rails are available in different sizes: single 3,2 m long rail, or supplied in two 1,6 m sections plus a 0,8 m extension.

BiDi

Yubii

Solemyo

Opera

Programmable via App

With Pro-View or Bidi-WiFi & MyNice Pro App.



Code	Description	Pcs./Pallet
<b>SPY650BDKCE</b>	Kit for automating sectional and up-and-over doors, 650 N, with SPYBOXB control unit, OXIBD receiver with connector included and 1 MYGO4 transmitter, with bidirectional technology. Guides not included	48
<b>SPY800BDKCE</b>	Kit for automating sectional and up-and-over doors, 800 N, with SPYBOXB control unit, OXIBD receiver with connector included and 1 MYGO4 transmitter, with bidirectional technology. Guides not included	48

**The SPY650BDKCE kit contains:**

Code	Description	Quantity
<b>SPY650</b>	Gearmotor 650 N	1
<b>SPYBOXB</b>	Control unit with LED courtesy light	1
<b>OXIBD</b>	Plug-in bidirectional radio receiver	1
<b>MYGO4</b>	Transmitter, 433,92 MHz, 4-channels	1

N.B. The contents of the pack may vary: always consult the dealer.

**The SPY800BDKCE kit contains:**

Code	Description	Quantity
<b>SPY800</b>	Gearmotor 800 N	1
<b>SPYBOXB</b>	Control unit with LED courtesy light	1
<b>OXIBD</b>	Plug-in bidirectional radio receiver	1
<b>MYGO4</b>	Transmitter, 433,92 MHz, 4-channels	1

N.B. The contents of the pack may vary: always consult the dealer.

**COMMON ACCESSORIES**

Code	Description	Pcs. Pack
<b>SPYLIGHT</b>	LED light module accessory for Spyrail (max 2 per Spyrail)	1
<b>PSS324</b>	24 V battery with integrated battery charger. Requires accessory TNA9 for wall mounting	1
<b>TNA9</b>	Additional connecting cable and supports for wall-mounting the PSS324 battery	1
<b>SPA5</b>	Swing arm sliding on bearings, optimised for projecting up-and-over doors	1
<b>SPA11</b>	Kit with additional ceiling fixing bracket for Spyrail	1
<b>SPA6</b>	Enlarged connecting arm, 585 mm long	1
<b>KI1</b>	Kit for release from outside with metal pull-cord and key ratchet	1
<b>SPA2</b>	Kit for release from outside with metal pull-cord	1
<b>SYKCE30</b>	Solar power supply kit consisting of SYP30 photovoltaic panel and PSY24 battery box with charging control circuit	1
<b>TS</b>	Sign	1

Find out more on page → 174.

**TECHNICAL SPECIFICATIONS**

Code	<b>SPY650BDKCE</b>	<b>SPY800BDKCE</b>
<b>ELECTRICAL SPECIFICATIONS</b>		
Power supply (VAC 50/60 Hz)	230 ± 10%	
Draw (A)	1,4	1,6
Maximum power (W)	250	300
Power in standby (W)	0,5	0,5
<b>PERFORMANCE DATA</b>		
Maximum speed (m/s)	0,15	0,14
Maximum force (N)	650	800
Nominal force (N)	200	250
Working cycle (cycles/hour)	30	30
Working cycle (cycles/day)	300	300
<b>DIMENSIONAL AND GENERAL DATA</b>		
Protection class (IP)	IP40	
Operating temperature (°C Min/Max)	-20 ÷ +55	
Pack dimensions (mm)	380x380x125	
Weight (kg)	3,2	3,4

**OPERATING LIMITS**

	Non-projecting up-and-over door (with SPA5)		Projecting up-and-over door (with SPA5) or with springs (without SPA5)		Sectional	
	H	W	H	W	H	W
SPY650BDKCE with 3,2 m track	2,3 m	4 m	2,8 m	4 m	2,5 m	4,2 m
SPY650BDKCE with 4 m track	3,1 m	3 m	3,5 m	3,3 m	3,3 m	3,2 m
SPY800BDKCE with 3,2 m track	2,3 m	5 m	2,8 m	5 m	2,5 m	5 m
SPY800BDKCE with 4 m track	3,1 m	3,7 m	3,5 m	4 m	3,3 m	3,8 m

Using maximum travel.

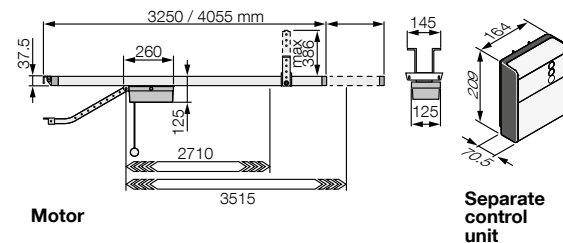
**DIMENSIONS**

**TECHNICAL SPECIFICATIONS OF TRACKS**

Code	Description	Pcs./Pallet
<b>SPYRAIL321</b>	1 x complete 3,2 m track	48
<b>SPYRAIL162</b>	2 x 1,6 m tracks with assembly accessories	48
<b>SPYRAIL081</b>	0,8 m extension with assembly accessories (to add to the other tracks to reach a length of 4 m)	48

Code	<b>SPYRAIL321</b>	<b>SPYRAIL162</b>	<b>SPYRAIL081*</b>
Type	3,2 m (one section)	3,2 m (2 x 1,6 m sects.)	0,8 m (extension to reach 4 m)
Installed track length (mm)	3270		4075
Useful travel (mm)	2710		3515
Weight (kg)	7,5	8,35	3,3
Pack dimensions (mm)	3230x110x50	1760x110x50	960x110x50
Dimensions accessories pack (mm)	400x400x90		

\* For use in combination with SPYRAIL321 and SPYRAIL162 tracks.

**COMPATIBILITY WITH CONTROL SYSTEMS AND ACCESSORIES**

**SPYBOX**  
**SPYBOXB**

<b>Control unit/Receiver</b>	
• •	<b>Integrated*</b>
•	<b>OXIBD / OXILR</b>
<b>Transmitter</b>	
• •	<b>ERA INTI</b> - 1 or 2 channels, 433.92 MHz, coloured
• •	<b>ERA ONE / MYGO</b> - 2, 4 or 8 channels, 433.92 MHz
• •	<b>MYGOBD / ERA ONE LR</b>
• •	<b>DOMi</b>
<b>Photocells</b>	
•	<b>EPS</b> - Slim / <b>EPM</b> - Medium / <b>EPL</b> - Large
•	<b>EPSB</b> - Slim, BlueBUS / <b>EPMB</b> - Medium, BlueBUS / <b>EPLB</b> - Large, BlueBUS
•	<b>EPMOR</b> - Medium, reflective
•	<b>EPMORB</b> - Medium, BlueBUS, reflective
•	<b>EPMOW</b> - Medium, wireless self-synchronised
•	<b>F210</b> - Synchronised, adjustable / <b>FT210</b> - For sensitive edges
•	<b>F210B</b> - BlueBUS
•	<b>FT210B</b> - For sensitive edges, BlueBUS
<b>Flashing light</b>	
<b>ELAC</b>	
• •	<b>ELDC</b>
• •	<b>WLT</b> - Multifunction LED light

\* Radio receiver not compatible with the O-box functions of the Opera system.

Nice

# Spykit 550

For sectional doors up to 9 m<sup>2</sup> and up-and-over doors (including canopy doors) up to 10,5 m<sup>2</sup>.



Available in a KIT



24V

Opera

Programmable via App

With Pro-View or Bidi-WiFi & MyNice Pro App.



24 Vdc irreversible electromechanical gear motor for residential use, transmission with rack on the rail.

To be combined with SPYRAIL321, SPYRAIL162 and SPYRAIL081 rails.

**Functional and stylish:** the motor is the only component that moves on the track, no chains or other noisy mechanisms. Ideal for any architectural context.

**Handy:** Separate control unit: more practical and convenient for programming and maintenance. Integrated LED courtesy light. Three practical keys to control the automation.

**Quick to install.** A new time-saving solution: the motor power supply module can be easily installed, either on one or the other side of the rail with simple gestures. Limit switches easy to position along the rail with no need to stand and work on the ceiling. No chains or other noisy mechanisms to install.

**Easy to program:** simple and fast basic programming, using the Quick Setup procedure. Simplified advanced programming, using Pro-View.

**ON/OFF release system:** pulling the release knob once releases the motor; pulling it a second time blocks the motor again, in any position along the rail.

**Inexpensive to run and environmentally-friendly:** when connected to the mains in standby mode, the control unit consumes 1,5 W.

**Safe:** obstacle detection, motor power monitoring during travel, diagnostic messages via flashing light and courtesy light.

Adjustable acceleration and deceleration at the start and end of each manoeuvre.

Ready for installation of the latest generation 8,2 kOhm resistive sensitive edges.

**Optimised logistics:** for practical management and transport, the rails are available in different sizes: single 3,2 m long rail, or supplied in two 1,6 m sections plus a 0,8 m extension.

Code	Description	Pcs./Pallet
<b>SPY550KCE</b>	Kit for the automation of sectional and up-and-over doors, 550 N, with SPYBOX control unit and 1 FLO2RE transmitter. Rails not included	48

**The kit contains:**

Code	Description	Quantity
<b>SPY550</b>	Gearmotor 550 N	1
<b>SPYBOX</b>	Control unit with integrated LED courtesy light and receiver	1
<b>INTI2</b>	Transmitter 433,92 MHz, 2 channels	1

**N.B.** The contents of the pack may vary: always consult the dealer.

**COMMON ACCESSORIES**

Code	Description	Pcs. Pack
<b>SPYLIGHT</b>	LED light module accessory for Spyrail (max 2 per Spyrail)	1
<b>SPA5</b>	Swing arm sliding on bearings, optimised for projecting up-and-over doors	1
<b>SPA6</b>	Enlarged connecting arm, 585 mm long	1
<b>KI1</b>	Kit for release from outside with metal pull-cord and key ratchet	1
<b>SPA2</b>	Kit for release from outside with metal pull-cord	1
<b>TS</b>	Sign	1

Find out more on page → 174.

**TECHNICAL SPECIFICATIONS**

Code	<b>SPY550KCE</b>
------	------------------

**ELECTRICAL SPECIFICATIONS**

Power supply (VAC 50/60 Hz)	230 ± 10%
Draw (A)	1,2
Maximum power (W)	200
Power in standby (W)	1,5

**PERFORMANCE DATA**

Maximum speed (m/s)	0,15
Maximum force (N)	550
Nominal force (N)	180
Working cycle (cycles/hour)	20
Working cycle (cycles/day)	200

**DIMENSIONAL AND GENERAL DATA**

Protection class (IP)	IP40
Operating temperature (°C Min/Max)	-20 ÷ +55
Pack dimensions (mm)	380x380x125
Weight (kg)	3,2

**OPERATING LIMITS**

	Non-projecting up-and-over door (with SPA5)		Projecting up-and-over door (with SPA5) or with springs (without SPA5)		Sectional	
	H	W	H	W	H	W
SPY550KCE with 3,2 m track	2,3 m	3,5 m	2,8 m	3,5 m	2,5 m	3,6 m
SPY550KCE with 4 m track	3,1 m	2,6 m	3,5 m	2,9 m	3,3 m	2,8 m

Using maximum travel.

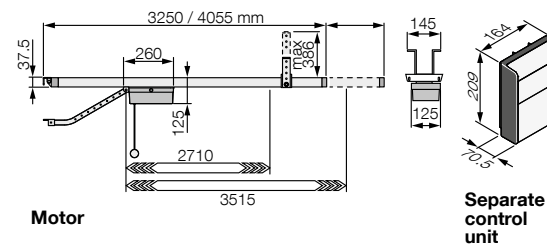
**DIMENSIONS****Motor****Separate control unit****TECHNICAL SPECIFICATIONS OF TRACKS**

Code	Description	Pcs./Pallet
<b>SPYRAIL321</b>	1 x complete 3,2 m track	48
<b>SPYRAIL162</b>	2 x 1,6 m tracks with assembly accessories	48
<b>SPYRAIL081</b>	0,8 m extension with assembly accessories (to add to the other tracks to reach a length of 4 m)	48

Code	<b>SPYRAIL321</b>	<b>SPYRAIL162</b>	<b>SPYRAIL081*</b>
Type	3,2 m (one section)	3,2 m (2 x 1,6 m sects.)	0,8 m (extension to reach 4 m)
Installed track length (mm)	3270		4075
Useful travel (mm)	2710		3515
Weight (kg)	7,5	8,35	3,3
Pack dimensions (mm)	3230x110x50	1760x110x50	960x110x50
Dimensions accessories pack (mm)	400x400x90		

\* For use in combination with SPYRAIL321 and SPYRAIL162 tracks.

**COMPATIBILITY WITH CONTROL SYSTEMS AND ACCESSORIES**

**SPYBOX**  
**SPYBOXB**

<b>Control unit/Receiver</b>
<ul style="list-style-type: none"> <li>• <b>Integrated*</b></li> <li>• <b>OXIBD / OXILR</b></li> </ul>
<b>Transmitter</b>
<ul style="list-style-type: none"> <li>• <b>ERA INTI</b> - 1 or 2 channels, 433.92 MHz, coloured</li> <li>• <b>ERA ONE / MYGO</b> - 2, 4 or 8 channels, 433.92 MHz</li> <li>• <b>MYGOBD / ERA ONE LR</b></li> <li>• <b>DOMI</b></li> </ul>
<b>Photocells</b>
<ul style="list-style-type: none"> <li>• <b>EPS</b> - Slim / <b>EPM</b> - Medium / <b>EPL</b> - Large</li> <li>• <b>EPSB</b> - Slim, BlueBUS / <b>EPMB</b> - Medium, BlueBUS / <b>EPLB</b> - Large, BlueBUS</li> <li>• <b>EPMOR</b> - Medium, reflective</li> <li>• <b>EPMORB</b> - Medium, BlueBUS, reflective</li> <li>• <b>EPMOW</b> - Medium, wireless self-synchronised</li> <li>• <b>F210</b> - Synchronised, adjustable / <b>FT210</b> - For sensitive edges</li> <li>• <b>F210B</b> - BlueBUS</li> <li>• <b>FT210B</b> - For sensitive edges, BlueBUS</li> </ul>
<b>Flashing light</b>
<b>ELAC</b>
<ul style="list-style-type: none"> <li>• <b>ELDC</b></li> <li>• <b>WLT</b> - Multifunction LED light</li> </ul>

\* Radio receiver not compatible with the O-box functions of the Opera system.

Nice

## Ten

For projecting and non-projecting up-and-over doors up to 9 m<sup>2</sup> and 2.6 m high (up to 16 m<sup>2</sup> and 2.6 m high using 2 motors).

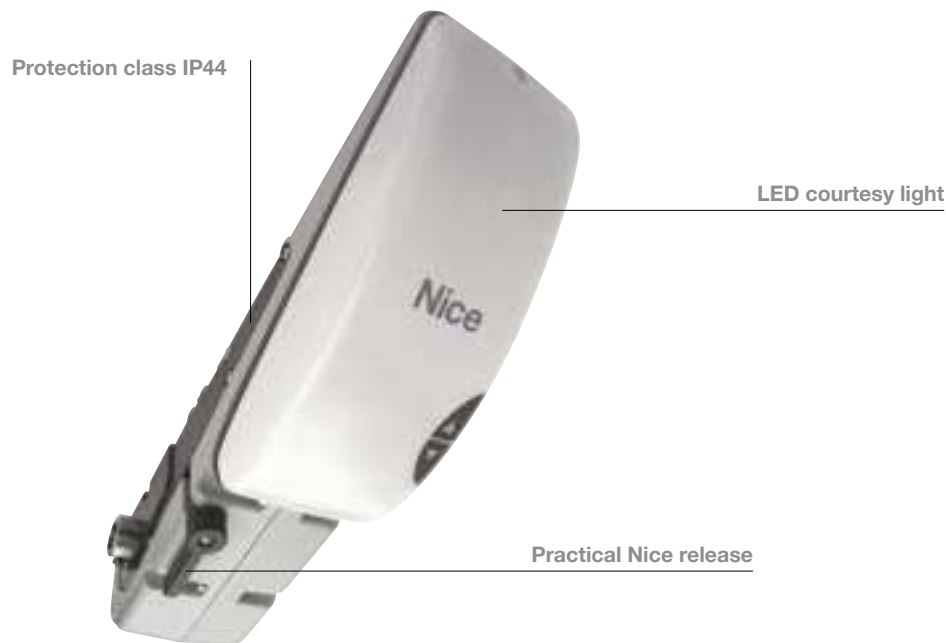

Electromechanical gearmotor, 24 VDC.

Three versions, standard and enhanced:

- with integrated control unit, force controller and absolute encoder (TN2010L);
- with built-in control unit and receiver and electromechanical limit switch (TN2030L);
- without control unit (TN2020L).

**Reliable and precise:** memorising of limit switch positions in opening and closing; gradual start and deceleration in opening and closing.

**Safe:** obstacle detection, monitoring of motor draw during travel, self-diagnostics via LED courtesy light and flashing light.

Compatible with connecting latest generation optical and resistive 8.2 KOhm sensitive edges.

**Functional:** possibility of combining a second motor without TN2020L control unit, to automate doors up to 16 m<sup>2</sup>.

**Model TN2030L with integrated radio receiver, compatible with Opera system.**

**Model TN2010L with BlueBUS technology and compatible with the Solemyo and Opera systems, compatible with the Yubii system and bidirectional receiver.**

**Advanced:** absolute encoder guarantees millimetric precision without the need for limit switches; reliable, retains set values over time.

**Simple:** thanks to the BlueBUS technology allowing connections with just two wires between the control unit and the photocells.

**Energy saving:** when the system is not in use, it switches to stand-by.

**Practical:** integrated control unit and PSS324 buffer batteries (optional) connected via a practical guided plug-in connector.

Compatible with Nice SMXI and OXI plug-in receivers (optional).

BlueBus

24V

BiDi

Yubii

Solemyo

Opera

Programmable via App

With Pro-View or Bidi-WiFi & MyNice Pro App.



Code	Description	Pcs./Pallet
<b>TN2010L</b>	Non-reversible, 24 VDC, with integrated control unit, LED courtesy light, absolute encoder and BlueBUS technology, compatible with Opera and Solemyo	15
<b>TN2030L</b>	Non-reversible, 24 VDC, with built-in control unit and receiver, LED courtesy light and electromechanical limit switch	15
<b>TN2020L</b>	Non-reversible, 24 VDC, with LED courtesy light, without integrated control unit	15

**COMMON ACCESSORIES**

Code	Description	Pcs. Pack
<b>SPTNA1R30</b>	Spare control unit for TN2030L and TNLKCE	1
<b>SPTNA2R30</b>	Spare control unit for TN2010L	1
<b>PSS324</b>	24 V battery with integrated battery charger. Only for TN2010L	1
<b>TNA9</b>	Additional connecting cable and supports for wall-mounting the PSS324 battery	1
<b>OTA2</b>	Motor bracket, length 1250 mm	1
<b>OTA3</b>	Motor bracket, length 2000 mm	1
<b>OTA9</b>	Motor bracket, length 520 mm	1
<b>TNA5</b>	Pair of standard straight telescopic arms	1
<b>TNA6</b>	Pair of standard curved telescopic arms	1
<b>TNA8</b>	Pair of drive shafts 20x20 mm, length 200 mm	1
<b>TNA4</b>	Pair of drive shafts 20x20 mm, length 1500 mm	1
<b>TNA38</b>	Drive device for 1 pair of drive shafts	1
<b>OTA11</b>	Kit for release from outside with metal pull-cord	1
<b>OTA12</b>	Kit for release from outside with key ratchet (cannot be used with side-mounted motors)	1
<b>SYKCE30</b>	Solar power supply kit consisting of SYP30 photovoltaic panel and PSY24 battery box with charging control circuit	1
<b>TS</b>	Sign	1

Find out more on page → 174.

**TECHNICAL SPECIFICATIONS**

Code	TN2010L	TN2010L+TN2020L	TN2030L	TN2030L+TN2020L
<b>ELECTRICAL SPECIFICATIONS</b>				
Power supply (VAC 50/60 Hz)	230			
Draw (A)	1	1,4	1	1,4
Power (W)	240	350	220	330
Power in standby (W)	<0.3W			
<b>PERFORMANCE DATA</b>				
Speed (m/s)	1,7		1,4	
Torque (Nm)	350	500	420	700
Working cycle (cycles/hour)	15	25	20	10
<b>DIMENSIONAL AND GENERAL DATA</b>				
Protection class (IP)	44			
Operating temperature (°C Min/Max)	-20 ÷ +50			
Dimensions (mm)	150x158x512 h			
Weight (kg)	10	17,2*	9,5	16,7*

\* 7.2 per TN2020L.

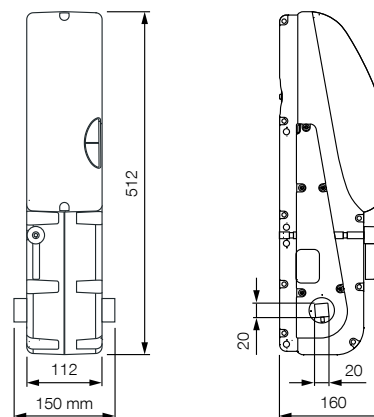
**DIMENSIONS****COMPATIBILITY WITH CONTROL SYSTEMS AND ACCESSORIES**

TN2010L TN2030L	Control unit/Receiver
	<ul style="list-style-type: none"> <li>• <b>Integrated*</b></li> <li>• <b>OXIBD / OXILR</b></li> </ul>
	Transmitter
	<ul style="list-style-type: none"> <li>• • <b>ERA INTI</b> - 2 channels, 433.92 MHz, different colours</li> <li>• • <b>ERA ONE / MYGO</b> - 2, 4 or 8 channels, 433.92 MHz</li> <li>• • <b>MYGOBD / ERA ONE LR</b></li> <li>• • <b>DOMi</b></li> </ul>
	Photocells
	<ul style="list-style-type: none"> <li>• <b>EPS</b> - Slim / <b>EPM</b> - Medium / <b>EPL</b> - Large</li> <li>• <b>EPSB</b> - Slim, BlueBUS / <b>EPMB</b> - Medium, BlueBUS / <b>EPLB</b> - Large, BlueBUS</li> <li>• <b>EPMOR</b> - Medium, reflective</li> <li>• <b>EPMORB</b> - Medium, BlueBUS, reflective</li> <li>• • <b>EPMOW</b> - Medium, wireless self-synchronised</li> <li>• <b>F210</b> - Synchronised, adjustable / <b>FT210</b> - For sensitive edges</li> <li>• <b>F210B</b> - BlueBUS</li> <li>• <b>FT210B</b> - For sensitive edges, BlueBUS</li> </ul>
	Flashing light
	ELAC
	<ul style="list-style-type: none"> <li>• • <b>ELDC</b></li> <li>• • <b>WLT</b> - Multifunction LED light</li> </ul>

\* Radio receiver not compatible with the O-box functions of the Opera system.

Nice

# Tenkit

For projecting and non-projecting up-and-over doors up to 9 m<sup>2</sup> and 2.6 m high.



Available in a KIT



BUS T4

Yubii

24V

Opera

Programmable via App

With Pro-View or Bidi-WiFi & MyNice Pro App.



Electromechanical gearmotor, non-reversible, 24 VDC.

**Functionality:** input for standard photocells and possibility of self-learning phototest connection during installation.

**Simplified programming via**

**Pro-View:** thanks to compatibility with the Opera system, the automation system can also be managed, programmed and controlled remotely, with considerable time savings.

**Convenience:** built-in radio card also compatible with Opera system, can memorise up to 100 transmitters. Key programming and automatic position search.

**Adjustments:** 3 force levels, 2 speeds, 3 pause time levels, 3 step-by-step modes.

**Maximum safety:** compatible with connecting latest generation 8.2 KOhm sensitive edges.

Obstacle detection and automatic programming of operating times, monitoring of motor draw during travel, self-diagnostics with flashing light and LED courtesy light.

Acceleration and deceleration at the start and end of each manoeuvre.

Code	Description	Pcs./Pallet
<b>TNLKCE</b>	Non-reversible, 24 VDC, with built-in control unit and receiver, LED courtesy light and electromechanical limit switch	15

**The TNLKCE kit contains:**

Code	Description	Quantity
<b>TNLKCE</b>	Gearmotor with built-in control unit and receiver, complete with pair of TNA5 telescopic arms and relative TNA38 drive devices	1
<b>INTI2</b>	Transmitter, 433.92 MHz, 2 channels	1
<b>TS</b>	Sign	1

**N.B.** The contents of the pack may vary: always consult the dealer.

**COMMON ACCESSORIES**

Code	Description	Pcs. Pack
<b>SPTNA1R30</b>	Spare control unit for TN2030L and TNLKCE	1
<b>OTA2</b>	Motor bracket, length 1250 mm	1
<b>OTA3</b>	Motor bracket, length 2000 mm	1
<b>OTA9</b>	Motor bracket, length 520 mm	1
<b>OTA11</b>	Kit for release from outside with metal pull-cord	1
<b>OTA12</b>	Kit for release from outside with key ratchet (cannot be used with side-mounted motors)	1
<b>TNA5</b>	Pair of standard straight telescopic arms	1
<b>TNA6</b>	Pair of standard curved telescopic arms	1
<b>TNA8</b>	Pair of drive shafts 20x20 mm, length 200 mm	1
<b>TNA4</b>	Pair of drive shafts 20x20 mm, length 1500 mm	1
<b>TNA38</b>	Drive device for 1 pair of drive shafts	1
<b>TS</b>	Sign	1

Find out more on page → 174.

**TECHNICAL SPECIFICATIONS**

Code	TNLKCE
<b>ELECTRICAL SPECIFICATIONS</b>	
Power supply (VAC 50/60 Hz)	230
Draw (A)	0,9
Power (W)	200
Power in standby (W)	<0.3W
<b>PERFORMANCE DATA</b>	
Speed (m/s)	1,7
Torque (Nm)	280
Working cycle (cycles/hour)	20
<b>DIMENSIONAL AND GENERAL DATA</b>	
Protection class (IP)	44
Operating temperature (°C Min/Max)	-20 ÷ +55
Dimensions (mm)	150x158x512 h
Weight (kg)	15,5

\* 7.2 per TN2020L.

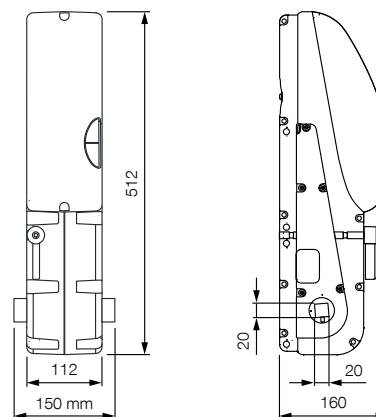
**DIMENSIONS**

**COMPATIBILITY WITH CONTROL SYSTEMS AND ACCESSORIES**
**TN2030L**
**Control unit/Receiver**

- **Integrated\***

**OXIBD / OXILR**
**Transmitter**

- **ERA INTI** - 2 channels, 433.92 MHz, different colours
- **ERA ONE / MYGO** - 2, 4 or 8 channels, 433.92 MHz

**MYGOBD / ERA ONE LR**

- **DOMi**

**Photocells**

- **EPS** - Slim / **EPM** - Medium / **EPL** - Large
- **EPSB** - Slim, BlueBUS / **EPMB** - Medium, BlueBUS / **EPLB** - Large, BlueBUS

- **EPMOR** - Medium, reflective

**EPMORB** - Medium, BlueBUS, reflective

- **EPMOW** - Medium, wireless self-synchronised

- **F210** - Synchronised, adjustable / **FT210** - For sensitive edges

**F210B** - BlueBUS

**FT210B** - For sensitive edges, BlueBUS

**Flashing light**
**ELAC**

- **ELDC**

- **WLT** - Multifunction LED light

\* Radio receiver not compatible with the O-box functions of the Opera system.

Nice

# Soon

## For sectional doors up to 20 m<sup>2</sup>.

For balanced sectional doors with anti-fallback system (safety device in case the balancing springs break).

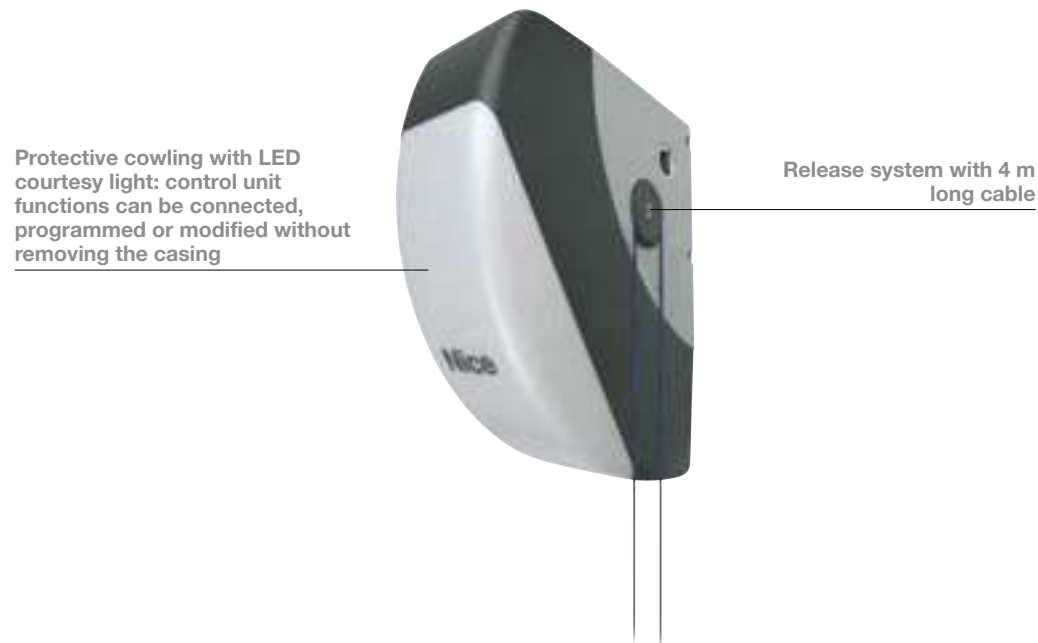

Electromechanical gearmotor, 24 VDC, with absolute encoder.

**Versatile:** ideal in residential contexts including with large garage doors, in multi-user contexts including with intensive use and in industrial contexts with small sectional doors. For example 3x3 m loading points.

**All-in-one:** integrated control centre. No track, no rack.

**Easy installation:** directly on the shaft of the sectional door; very small, especially in width, for easy mounting in any position.

**Ultra-simple, thanks to the BlueBUS system:** connections with two wires between the control unit and the pairs of photocells.

**Practical:** control unit and PSS124 buffer batteries (optional) housed inside, connected with practical guided plug-in connector.

**Energy saving:** when the system is not in use, it switches to stand-by.

**Reliable and precise:** memorising of limit switch positions in opening and closing; gradual start and deceleration in opening and closing; the absolute encoder technology guarantees precision without the need for limit switches, reliability, retains set values over time.

**Safe:** obstacle detection, monitoring of motor draw during travel, self-diagnostics via LED courtesy light and flashing light.

Compatible with connecting latest generation optical and resistive 8.2 KOhm sensitive edges.

**Easy maintenance:** removable terminals and receiver.

**Easy certification:** passes impact tests without additional accessories.

BlueBus

BiDi

Programmable via App

24V

Yubii

With Pro-View or Bidi-WiFi & MyNice Pro App.

Solemyo

Opera



Code	Description	Pcs./Pallet
<b>SO2000</b>	Non-reversible, 24 VDC, with absolute encoder for doors up to 5 m high	20

**COMMON ACCESSORIES**

Code	Description	Pcs. Pack
<b>SPSOA2R30</b>	Spare control unit for SO2000	1
<b>PSS124</b>	24 V battery with integrated battery charger	1
<b>CRA9</b>	Adapter for shafts with 31.75 (1 1/4") diameter - 35 - 40 mm	1
<b>SYKCE30</b>	Solar power supply kit consisting of SYP30 photovoltaic panel and PSY24 battery box with charging control circuit	1
<b>TS</b>	Sign	1

Find out more on page → 174.

**TECHNICAL SPECIFICATIONS**

Code	SO2000
<b>ELECTRICAL SPECIFICATIONS</b>	
Power supply (VAC 50/60 Hz)	230
Draw (A)	1,6
Power (W)	350
Power in standby (W)	<0.3W
<b>PERFORMANCE DATA</b>	
Speed (m/s)	30
Torque (Nm)	50
Working cycle (cycles/hour)	15
<b>DIMENSIONAL AND GENERAL DATA</b>	
Protection class (IP)	44
Operating temperature (°C Min/Max)	-20 ÷ +50
Dimensions (mm)	115x300x375 h
Weight (kg)	10,5

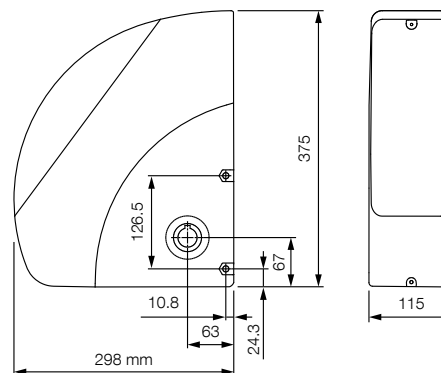
**DIMENSIONS****COMPATIBILITY WITH CONTROL SYSTEMS AND ACCESSORIES**

SO2000
<b>Control unit/Receiver</b>
<b>Integrated*</b>
• <b>OXIBD / OXILR</b>
<b>Transmitter</b>
• <b>ERA INTI</b> - 2 channels, 433.92 MHz, different colours
• <b>ERA ONE / MYGO</b> - 2, 4 or 8 channels, 433.92 MHz
• <b>MYGOBD / ERA ONE LR</b>
• <b>DOMi</b>
<b>Photocells</b>
<b>EPS</b> - Slim / <b>EPM</b> - Medium / <b>EPL</b> - Large
• <b>EPSB</b> - Slim, BlueBUS / <b>EPMB</b> - Medium, BlueBUS / <b>EPLB</b> - Large, BlueBUS
<b>EPMOR</b> - Medium, reflective
• <b>EPMORB</b> - Medium, BlueBUS, reflective
• <b>EPMOW</b> - Medium, wireless self-synchronised
<b>F210</b> - Synchronised, adjustable / <b>FT210</b> - For sensitive edges
• <b>F210B</b> - BlueBUS
• <b>FT210B</b> - For sensitive edges, BlueBUS
<b>Flashing light</b>
<b>ELAC</b>
• <b>ELDC</b>
• <b>WLT</b> - Multifunction LED light

\* Radio receiver not compatible with the O-box functions of the Opera system.

Nice

# Sumo

For sectional doors and two-leaf sliding doors up to 35 m<sup>2</sup>.

Ultra-compact casing made entirely in thick cast aluminium

6.5 m cable release m with emergency handle



Compartment inspectable and easily accessible for connections

Electromechanical gearmotor, 24 VDC, with magnetic encoder, no limit switch adjustment required.

Ideal for intensive use.

**Compact and versatile:** very small, especially in width, for easy mounting in any position; fast installation.

**Easy to install:** directly on the shaft of the sectional door. Ideal for Ø 25,4 mm shafts and can also be used on Ø 31,75-35-40 mm shafts, thanks to the CRA9 adapter.

**Many different functions with the separate D-Pro 924 control unit:**

- memorising of limit switches in opening and closing;
- gradual start and deceleration in opening and closing;
- optional battery power supply in the event of power failure;
- programming of pause time and regulation of movement speed;
- “service” maintenance warning (programmable according to the desired number of manoeuvres).

BUS T4

BiDi

Programmable via App

24V

Yubii

With Pro-View or Bidi-WiFi & MyNice Pro App.

Opera



Code	Description	Pcs./Pallet
<b>SU2000</b>	Non-reversible, 24 VDC, with magnetic encoder, no limit switch adjustment required, for doors from 15 m <sup>2</sup> to 35 m <sup>2</sup>	20
<b>SU2000V</b>	Non-reversible, 24 VDC, with magnetic encoder, no limit switch adjustment required, fast, for doors from 10 m <sup>2</sup> to 25 m <sup>2</sup>	20
<b>SU2000VV</b>	Non-reversible, 24 VDC, with magnetic encoder, no limit switch adjustment required, super-fast, for doors from 10 m <sup>2</sup> to 15 m <sup>2</sup>	20
<b>SU2010</b>	Non-reversible, 24 VDC, with magnetic encoder, no limit switch adjustment required, IP54, for doors from 15 m <sup>2</sup> to 35 m <sup>2</sup>	20

#### COMMON ACCESSORIES

Code	Description	Pcs. Pack
<b>DPRO924</b>	Control unit	1
<b>KIO</b>	Key switch for low-voltage contacts, with release mechanism for metal cable	1
<b>KA1</b>	Kit with 6 m metal cable for KIO	1
<b>CRA1</b>	Shaft with 18-tooth pinion, shaft Ø 25.4 mm, crown int. Ø 25.4 mm	1
<b>CRA2</b>	Coupling for chain	1
<b>CRA5</b>	Chain tensioner with brackets, ideal for 1- or 2-leaf industrial doors	1
<b>CRA3</b>	1/2" chain, 1 m pack with coupling	1
<b>CRA4</b>	1/2" chain, 5 m pack, ideal for 1- or 2-leaf industrial doors with coupling	1
<b>CRA8</b>	Wall mounting bracket	2
<b>CRA9</b>	Adapter for shafts with 31.75 (1 1/4") diameter - 35 - 40 mm	1
<b>CRA6</b>	36-tooth crown, int. Ø 25.4 mm	1
<b>CRA7</b>	18-tooth crown, int. Ø 25.4 mm	1
<b>TS</b>	Sign	1

Find out more on page → 174.

#### TECHNICAL SPECIFICATIONS

Code	SU2000	SU2000V	SU2000VV	SU2010
<b>ELECTRICAL SPECIFICATIONS</b>				
Power supply (VDC)	24			
Draw (A)	13			
Power (W)	500			
<b>PERFORMANCE DATA</b>				
Speed (m/s)	16	23,5	42	16
Torque (Nm)	120	82	46	120
Work cycle (%)	50			
<b>DIMENSIONAL AND GENERAL DATA</b>				
Protection class (IP)	44			54
Operating temperature (°C Min/Max)	-20 ÷ +50			
Dimensions (mm)	110x270x350 h			
Weight (kg)	10,5			

#### DIMENSIONS

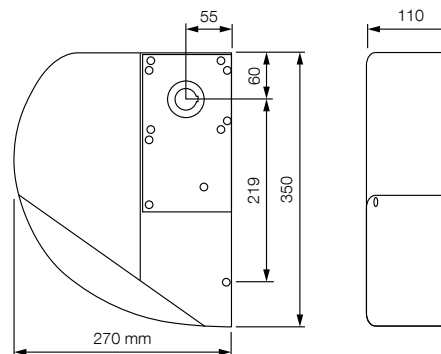

#### COMPATIBILITY WITH CONTROL SYSTEMS AND ACCESSORIES

SU2000	SU2000V	SU2000VV	SU2010
<b>Control unit/Receiver</b>			
• • • • DPRO924 / OXIBD / OXILR			
<b>Transmitter</b>			
• • • • ERA INTI - 2 channels, 433.92 MHz, different colours			
• • • • ERA ONE / MYGO - 2, 4 or 8 channels, 433.92 MHz			
• • • • MYGOBD / ERA ONE LR			
• • • • DOMi			
<b>Photocells</b>			
• • • • EPS - Slim / EPM - Medium / EPL - Large			
• • • • EPSB - Slim, BlueBUS / EPMB - Medium, BlueBUS / EPLB - Large, BlueBUS			
• • • • EPMOR - Medium, reflective			
• • • • EPMORB - Medium, BlueBUS, reflective			
• • • • EPMOW - Medium, wireless self-synchronised			
• • • • F210 - Synchronised, adjustable / FT210 - For sensitive edges			
• • • • F210B - BlueBUS			
• • • • FT210B - For sensitive edges, BlueBUS			
<b>Flashing light</b>			
• • • • ELAC			
• • • • ELDC			
• • • • WLT - Multifunction LED light			

\* Radio receiver not compatible with the O-box functions of the Opera system.

Nice

# Hyppo

For two-leaf folding doors.



Shock-proof body without sharp edges, minimal size

Nice aluminium release and compatible with release from outside

Non-reversible electromechanical gearmotor with telescopic arm, also available in 24 VDC version, with magnetic encoder.  
One model for right or left leaf.

**Built-in double limit switch:** in both opening and closing, pre-wired: fewer connections and fast installation (for HY7100 only).

**100% metal mechanics.**

**Sturdy galvanised telescopic arm.**

**Recommended control units:**

- for HY7100 Moonclever MC800;
- for HY7124 Moonclever MC824H.

**24 VDC version with magnetic encoder.**

Ideal for intensive use, compatible with Moonclever MC824H control unit:

- simple programming with a single key;
- self-learning of opening and closing limit switches;
- fault self-diagnostics;
- programming of pause time;
- pedestrian pass door;
- deceleration in opening and closing;
- double technology obstacle detection;
- operation in event of power failure with optional rechargeable batteries (PSS324);
- compatible with connecting latest generation 8.2 KOhm resistive sensitive edges.

BlueBus

BiDi

Programmable via App

24V

Yubii

With Pro-View or Bidi-WiFi & MyNice Pro App.

230V

Solemyo

Opera



Code	Description	Pcs./Pallet
<b>HY7100</b>	Non-reversible, 230 VAC, complete with galvanised and painted telescopic arm, with limit switches in opening and closing	16
<b>HY7124</b>	Non-reversible, 24 VDC, with magnetic encoder, complete with galvanised and painted telescopic arm	16

#### COMMON ACCESSORIES

Code	Description	Pcs. Pack
<b>HYA11</b>	Release from inside with 6 m cable	1
<b>KIO</b>	Key switch for low-voltage contacts, with release mechanism for metal cable	1
<b>KA1</b>	Kit with 6 m metal cable for KIO	1
<b>TS</b>	Sign	1

#### ACCESSORIES FOR 24 V VERSIONS

Code	Description	Pcs. Pack
<b>PSS324</b>	24 V battery with integrated battery charger	1
<b>SYKCE30</b>	Solar power supply kit consisting of SYP30 photovoltaic panel and PSY24 battery box with charging control circuit	1

Find out more on page → 174.

#### TECHNICAL SPECIFICATIONS

Code	HY7100	HY7124
<b>ELECTRICAL SPECIFICATIONS</b>		
Power supply (VAC 50 Hz)*	230	-
Power supply (VDC)	-	24
Draw (A)	1,2	5
Power (W)	250	120
<b>PERFORMANCE DATA</b>		
Speed (m/s)	1,7	2
Torque (Nm)	400	250
Work cycle (%)	30	80
<b>DIMENSIONAL AND GENERAL DATA</b>		
Protection class (IP)	20	
Operating temperature (°C Min/Max)	-20 ÷ +50	
Dimensions (mm)	350x165x242 h	
Weight (kg)	13	

#### OPERATING LIMITS

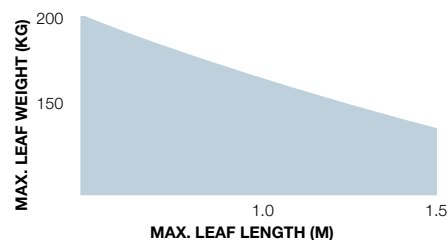

The values described above refer to use of motors with standard accessories.

#### DIMENSIONS

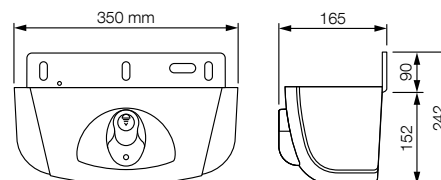

#### COMPATIBILITY WITH CONTROL SYSTEMS AND ACCESSORIES

HY7100	HY7124
<b>Control unit/Receiver</b>	
<ul style="list-style-type: none"> <li>• <b>MC800 / OXIBD / OXILR</b></li> <li>• <b>MC824H / OXIBD / OXILR</b></li> </ul>	
<b>Transmitter</b>	
<ul style="list-style-type: none"> <li>• <b>ERA INTI</b> - 2 channels, 433.92 MHz, different colours</li> <li>• <b>ERA ONE / MYGO</b> - 2, 4 or 8 channels, 433.92 MHz</li> <li>• <b>MYGOBD / ERA ONE LR</b></li> <li>• <b>DOMI</b></li> </ul>	
<b>Photocells</b>	
<ul style="list-style-type: none"> <li>• <b>EPS</b> - Slim / <b>EPM</b> - Medium / <b>EPL</b> - Large</li> <li>• <b>EPSB</b> - Slim, BlueBUS / <b>EPMB</b> - Medium, BlueBUS / <b>EPLB</b> - Large, BlueBUS</li> <li>• <b>EPMOR</b> - Medium, reflective</li> <li>• <b>EPMORB</b> - Medium, BlueBUS, reflective</li> <li>• <b>EPMOW</b> - Medium, wireless self-synchronised</li> <li>• <b>F210</b> - Synchronised, adjustable / <b>FT210</b> - For sensitive edges</li> <li>• <b>F210B</b> - BlueBUS</li> <li>• <b>FT210B</b> - For sensitive edges, BlueBUS</li> </ul>	
<b>Flashing light</b>	
<ul style="list-style-type: none"> <li>• <b>ELAC</b></li> <li>• <b>ELDC</b></li> <li>• <b>WLT</b> - Multifunction LED light</li> </ul>	

\* Radio receiver not compatible with the O-box functions of the Opera system.

**Nice for  
balanced rolling doors**



Nice

# Selection guide

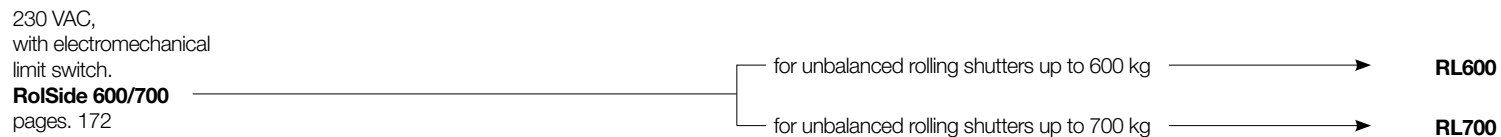
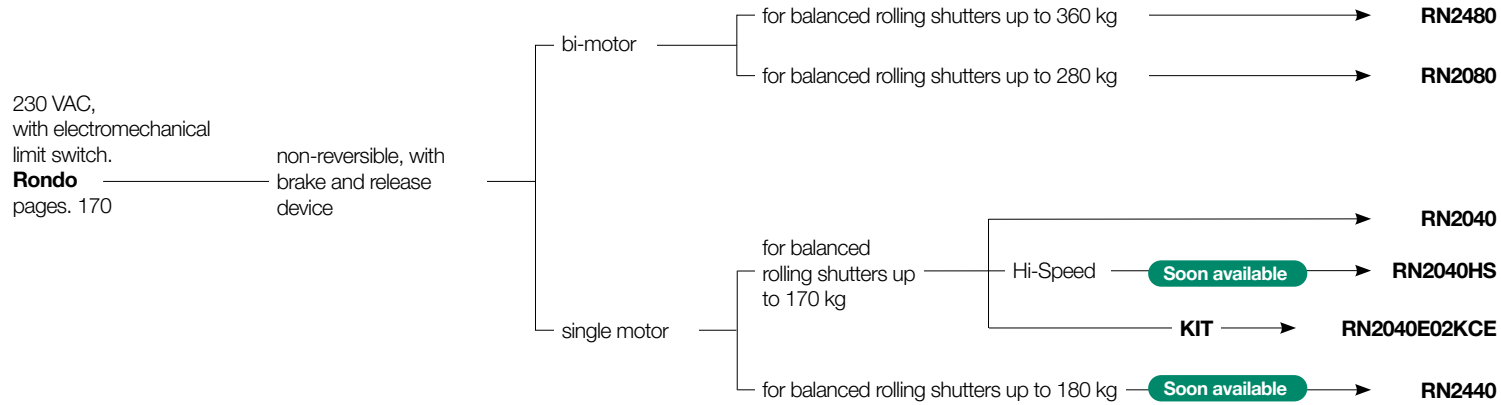

Soon available



Nice

# Rondo

For balanced rolling doors  
up to 360 kg.

Model RN2040



Sturdy: body  
100% aluminium

Easy to programme: easy to  
adjust electromechanical limit  
switches in both opening and  
closing

Complete:  
provision  
for cable  
release

230V

Opera

Programmable via  
App

With Pro-View or  
Bidi-WiFi & MyNice  
Pro App.



Non-reversible electromechanical gearmotor.

**Easy to programme:** Simple adjustment of the mechanical limit switches thanks to the new white tab that allows the wheels used to adjust the rolling door opening and closing positions to be disengaged easily.

**Easy to install:** A few simple steps are all it takes to efficiently install the gearmotor on the spring shaft. Thanks to the crown and spring shaft adapters available, the product can satisfy a wide range of installation requirements.

**Easy to use:** Simple release system to block and release the rolling door from the ground (release cable 7 m long for double motor models, 5 m long for the single motor model).

**Performance:** High Speed version with 20 rpm for quick opening and closing.

Model RN2040HS



**Safe:** All models in the range are fitted with an electro-brake. If there is a blackout while the rolling door is open, there is no risk of it falling.

**Versatile:** The new mechanical limit switch system allows the automation to be installed on rolling doors up to 7 m high.

**Recommended MC200 control unit, easy, complete and reliable with:**

- Auto-close function;
- Compatible with security sensitive edges;
- Stopping behavior. Stop or stop and short reversal;
- Programmable SbS input in Open;
- Built-in Stand by function;
- Connecting photocells with Phototest;
- Courtesy light function combined with photocells;
- Courtesy light function combined with photocells used as a closing command;
- Integrated radio compatible with the Opera system.

Twin motor models RN2080 and RN2480  
complete the range



Photo shows model RN2480.

\* Soon available

Code	Description	Pcs./Pallet
<b>RN2480</b>	For balanced rolling doors up to 360 kg, non-reversible, with electro-brake and release device	30
<b>RN2080</b>	For balanced rolling doors up to 280 kg, non-reversible, with electro-brake and release device	40
* <b>RN2440</b>	For balanced rolling doors up to 180 kg, non-reversible, with electro-brake and release device	40
<b>RN2040</b>	For balanced rolling doors up to 170 kg, non-reversible, with electro-brake and release device	40
* <b>RN2040HS</b>	For balanced rolling doors up to 170 kg, High Speed, with electro-brake, and release device	40
<b>RN2040E02KCE</b>	Kit for automating balanced rolling doors up to 170 kg, non-reversible, with electro-brake and release device. The kit contains RN2040, 2 x INTI2, 1 x MC200, 1 x KIOMINI	40

**The RN2040E02KCE kit contains:**

Code	Description	Quantity
<b>RN2040</b>	Non-reversible electromechanical gearmotor, 24 VDC, for balanced rolling doors up with electro-brake, and release device	1
<b>INTI2</b>	Transmitter, 433.92 MHz, 2 channels	2
<b>MC200</b>	Control unit with automatic closing	1
<b>KIOMINI</b>	Aluminium key switch with control and release button	1

N.B. The contents of the pack may vary: always consult the dealer.

**COMMON ACCESSORIES**

Code	Description	Pcs. Pack
<b>MC200</b>	Control unit with automatic closing	1
<b>RNA02</b>	Ø 42 mm shaft adapter for Rondo	1
<b>KIO</b>	Key switch for low-voltage contacts, with release mechanism for metal cable	1
<b>KIOMINI</b>	Aluminium key switch with control and release button	1
<b>TS</b>	Sign	1

Find out more on page → 174.

**COMPATIBILITY WITH CONTROL SYSTEMS AND ACCESSORIES**

RN2480 RN2080 RN2440 RN2040/HS	Control unit/Receiver
	• • • • MC200 / Integrated*
	<b>Transmitter</b>
	• • • • ERA INTI - 2 channels, 433.92 MHz, different colours
	• • • • ERA ONE / MYGO - 2, 4 or 8 channels, 433.92 MHz
	• • • • ERA FLOR / DOMi
	<b>Photocells</b>
	• • • • EPS - Slim / EPM - Medium / EPL - Large
	• • • • EPMOR - Medium, reflective
	• • • • EPMOW - Medium, wireless self-synchronised
	• • • • F210 - Synchronised, adjustable / FT210 - For sensitive edges
	<b>Flashing light</b>
	• • • • ELAC

\* Radio receiver not compatible with the O-box functions of the Opera system.

**TECHNICAL SPECIFICATIONS**

Code	RN2480	RN2080	RN2440	RN2040	RN2040HS
<b>ELECTRICAL SPECIFICATIONS</b>					
Power supply (VAC 50 Hz)*	230	230	230	230	230
Draw (A)	5,4	5,4	2,7	2,7	3
Power (W)	1.260	1.260	630	630	690
<b>PERFORMANCE DATA</b>					
Speed (Rpm)	9	10	9	10	20
Torque (Nm)	400	280	210	170	170
Continuous operating time (min)	4	4	4	4	4
Limit switch (m)	7	7	7	7	7
<b>DIMENSIONAL AND GENERAL DATA</b>					
Shaft diameter (mm)	76	60	76	60	60
Shaft adapters**	-	-	-	48	48
Crown diameter (mm)	240	200	240	200	200
Crown adapters**	-	220	-	220	220
Electro-brake	Si	Si	Si	Si	Si
Release cable (m)	7	7	5	5	5
Power cable (length in m)	4x1 mm <sup>2</sup> (6 m)	4x1 mm <sup>2</sup> (6 m)	4x0.75 mm <sup>2</sup> (4 m)	4x0.75 mm <sup>2</sup> (4 m)	4x0.75 mm <sup>2</sup> (4 m)
Protection class (IP)	20	20	20	20	20
Operating temperature (°C Min/Max)	-20 ÷ +55	-20 ÷ +55	-20 ÷ +50	-20 ÷ +50	-20 ÷ +50
Dimensions (mm)	240x370	200x350	240x320	200x350	200x350
Weight (kg)	17	14	10	8	9

\* 120 VAC version available on request. \*\*Included with product.

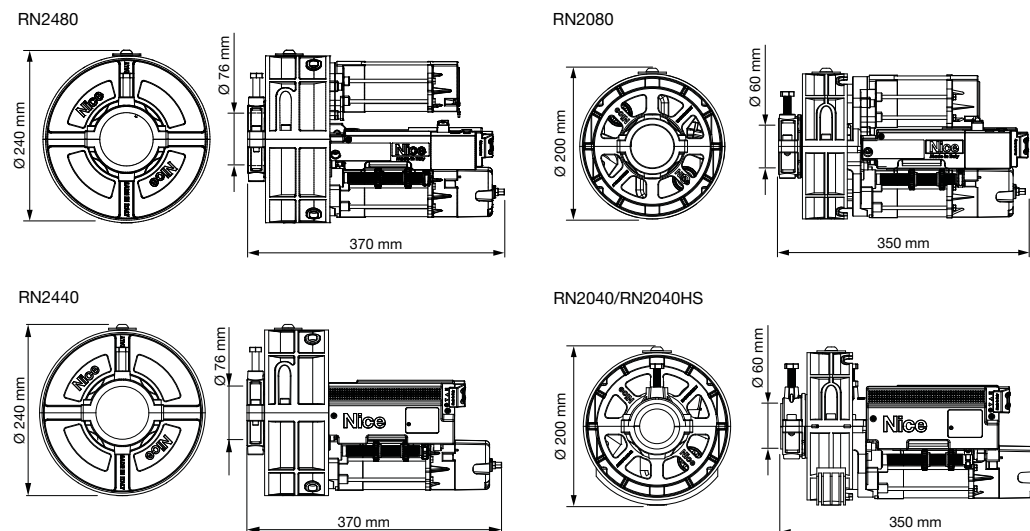
**DIMENSIONS**

Nice

# RolSide 600/700

For unbalanced rolling shutters up to 700 kg.

Soon available

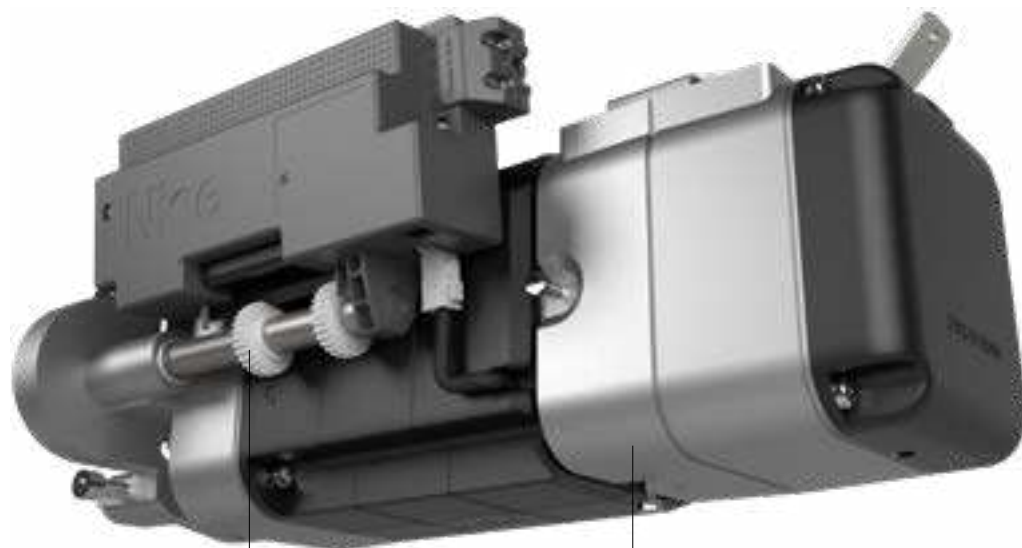

Easy to program:  
easy adjustment of  
electromechanical limit  
switches both in opening and  
closing

Robust: body  
100% aluminum

230V

Flor

Opera

## Easy to install

- Limit switch programming as central motors;
- Intuitive installation positioned on the left side;
- Programming guided by the buzzer.

## Easy to use

- Control via transmitters when used with the MC200/MC200L control unit;
- Control via wired SbS input or via Open/Stop/Close input when combined with the MC200L control unit;
- Automatic closing function;
- Man present function during the closing maneuver.

## Safety

- Parachute compatibility in case of blackout or motor failure (TS – 40) double micro descent and ascent: safety even in automatic mode;
- Chain safety system: chain lock in case of breakage;
- Compatible with NC safety edge when paired with the MC200/MC200L control unit;
- Compatible with photocells when paired with the MC200/MC200L control unit.

## CONTROL SYSTEMS



### MC200

Control unit for balanced and unbalanced rolling shutters (Rondo, Rolside motors) programmable via MyNice Pro App



### MC200L

Control unit for balanced and unbalanced rolling shutters (Rondo, Rolside motors)



### MYGO

4 channels transmitter with 433.92 MHz frequency, O-Code encoding



### INTI

2 channels transmitter with 433.92 MHz frequency, O-Code encoding

Find out more on page → 214

→ 215

→ 181

→ 184

Code	Description	Pcs./Pallet
<b>RL700</b>	For unbalanced rolling shutters up to 700 kg	38
<b>RL600</b>	For unbalanced rolling shutters up to 600 kg	38

**COMMON ACCESSORIES**

Code	Description	Pcs. Pack
<b>MC200L</b>	Control unit for balanced and unbalanced rolling shutters (Rondo, Rolside motors)	1
<b>MC200</b>	Control unit for balanced and unbalanced rolling shutters (Rondo, Rolside motors) programmable via MyNice Pro App	1
<b>TS300B</b>	Transmission bracket kit: transmission bracket without cover, transmission ratio 1:6 + bearing (for tube $\varnothing$ 30) + shaft $\varnothing$ 30 + flanges $\varnothing$ 4 inches	1
<b>UCP 206</b>	Bearing for TS300B transmission bracket (for tube $\varnothing$ 30)	1
<b>TS - 40</b>	Parachute diameter 40 mm	1
<b>TS - 320</b>	Wall support for parachute	1

**COMPATIBILITY WITH CONTROL SYSTEMS AND ACCESSORIES**RL600  
RL700**Control unit/Receiver**

- **MC200 / MC200L / Integrated\***

**Transmitter**

- **ERA INTI** - 2 channels, 433.92 MHz, various colors
- **ERA ONE / MYGO** - 1, 2, 4 or 9 channels, 433,92 MHz

**MYGOBD / ERA ONE LR**

- **ERA FLOR**

**Photocells**

- **EPS** - Slim / **EPM** - Medium / **EPL** - Large
- **EPSB** - Slim, BlueBUS / **EPMB** - Medium, BlueBUS / **EPLB** - Large, BlueBUS
- **EPMOR** - Medium, reflective
- **EPMORB** - Medium, BlueBUS, reflective
- **EPMOW** - Medium, wireless, self-synchronized
- **F210** - Synchronized, adjustable / **FT210** - For sensitive edges
- **F210B** - BlueBUS
- **FT210B** - For sensitive edges, BlueBUS

**Flashing light**

- **ELAC**
- **ELDC**
- **WLT** - Multifunction LED light

\* Radio receiver not compatible with the O-box functions of the Opera system.

**TECHNICAL DATA**

Code	RL700	RL600
<b>ELECTRICAL DATA</b>		
Power supply (VAC 50 Hz)*	230	230
Power (W)	800	600
<b>PERFORMANCE DATA</b>		
Rpm	10	9
Torque (Nm)	480	412
Lifting capacity (Kg)	700	600
Continuous operating time (min)	5	5
Limit switch (m)	9	9
<b>DIMENSIONAL AND GENERAL DATA</b>		
Motor shaft diameter (m)	0,44	0,44
Chain type	10A	10A
Protection class (IP)	30	30
Operating temperature (°C min/max)	-20 ÷ +55	-20 ÷ +55
Dimensions (mm)	400x220x140	400x220x140
Weight (kg)	13.5	13.4

\* 120 VAC version available on request. \*\*Included with the product.

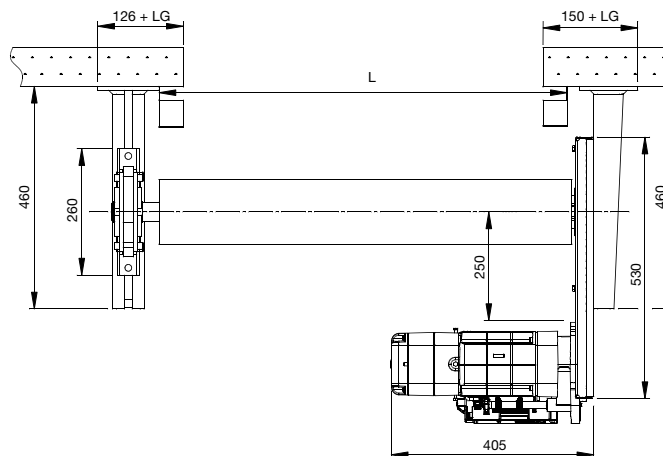
**DIMENSIONS**

# Accessories for garage and industrial doors

## ACCESSORIES



**SPA2**  
Kit for release from outside with metal pull-cord.  
Pcs./pack 1



**SPA5**  
Swing arm sliding on bearings, optimised for projecting up-and-over doors.  
Pcs./pack 1



**SPA6**  
Enlarged connecting arm, 585 mm long.  
Pcs./pack 1



**SPA7**  
Kit with two additional fixing brackets.  
Pcs./pack 2



**SPA11**  
Kit with additional ceiling fixing bracket for Spyrail.  
Pcs./pack 1



**SRA1**  
Quick-fit bracket for ceiling assembly.  
Suitable for SR guide.  
Pcs./pack 1



**SNA16**  
Quick-connect bracket for ceiling mounting.  
Suitable for SNA guide.  
Pcs./pack 10



**OTA2**  
Motor bracket, length 1250 mm.  
Pcs./pack 1



**OTA3**  
Motor bracket, length 2000 mm.  
Pcs./pack 1



**OTA9**  
Motor bracket, length 520 mm.  
Pcs./pack 1



**TNA5**  
Pair of standard straight telescopic arms.  
Pcs./pack 1



**TNA6**  
Pair of standard curved telescopic arms.  
Pcs./pack 1



**TNA8**  
Pair of drive shafts 20x20 mm, length 200 mm.  
Pcs./pack 1



**TNA4**  
Pair of drive shafts 20x20 mm, length 1500 mm.  
Pcs./pack 1



**TNA38**  
Drive device for 1 pair of drive shafts.  
Pcs./pack 1



**OTA11**  
Kit for release from outside with metal pull-cord.  
Pcs./pack 1



**OTA12**  
Kit for release from outside with key ratchet (cannot be used with side-mounted motors).  
Pcs./pack 1



**CRA1**  
Shaft with 18-tooth pinion, shaft Ø 25.4 mm, crown int. Ø 25.4 mm.  
Pcs./pack 1



**CRA2**  
Coupling for chain.  
Pcs./pack 1



**CRA3**  
1/2" chain, 1 m pack with coupling.  
Pcs./pack 1



**CRA4**  
1/2" chain, 5 m pack, ideal for 1- or 2-leaf industrial doors with coupling.  
Pcs./pack 1



**CRA5**  
Chain tensioner with brackets, ideal for 1- or 2-leaf industrial doors.  
Pcs./pack 1



**CRA6**  
36-tooth crown, int. Ø 25.4 mm.  
Pcs./pack 1



**CRA7**  
18-tooth crown, int. Ø 25.4 mm.  
Pcs./pack 1



**CRA8**  
Wall mounting bracket.  
Pcs./pack 2



**CRA9**  
Adapter for shafts with 31.75 (1 1/4") diameter - 35 - 40 mm.  
Pcs./pack 1



**RNA02**  
Ø 42 mm shaft adapter for Rondo.  
Pcs./pack 1



**HYA11**  
Release from inside with  
6 m cable.  
Pcs./pack 1



**KIO**  
Key switch for low-volt-  
age contacts, with  
release mechanism for  
metal cable.  
Pcs./pack 1



**KIOMINI**  
Aluminium key switch  
with control and release  
button.  
Pcs./pack 1



**KA1**  
Kit with 6 m metal cable  
for KIO.  
Pcs./pack 1



**WLT**  
Multifunction LED signal  
light. See page 203.  
Pcs./pack 1



**TS**  
Sign.  
Pcs./pack 1

#### SPARE CONTROL UNITS



**SPSPA600R30**  
Spare control unit for  
SPIDO32BKCE, SPI-  
DO32CKCE, SPIDO16B-  
KCE, SPIDO16CKCE.  
Pcs./pack 1



**SPMCU1R30**  
Spare control unit for  
SPIDER800.  
Pcs./pack 1



**SPMCU2R30**  
Spare control unit for  
SPIDER800W.  
Pcs./pack 1



**MCU4**  
Spare control unit for  
SPIDER1200BLW.  
Pcs./pack 1



**SPSOA2R30**  
Spare control unit for  
SO2000.  
Pcs./pack 1



**SPTNA1R30**  
Spare control unit for  
TN2030L and TNLKCE.  
Pcs./pack 1



**SPTNA2R30**  
Spare control unit for  
TN2010L.  
Pcs./pack 1

#### EXPANSION BOARD FOR CONTROL UNIT MCU1, MCU2 AND MCU4



**MLAE21**  
Plug-in expansion board  
1 Output 2 Input.  
Pcs./pack 1



**MLAE22**  
Plug-in expansion board  
2 Output (1 230V Relay)  
2 Input.  
Pcs./pack 1



**MLAE44**  
Plug-in expansion board  
4 Output 4 Input.  
Pcs./pack 1

#### ACCESSORIES FOR 24 V VERSIONS



**PSS124**  
24 V battery with inte-  
grated battery charger.  
Pcs./pack 1



**PSS324**  
24 V battery with inte-  
grated battery charger.  
Pcs./pack 1



**TNA9**  
Additional connecting  
cable and supports  
for wall-mounting the  
PSS324 battery.  
Pcs./pack 1

Nice

## Standard installation diagram for garage doors

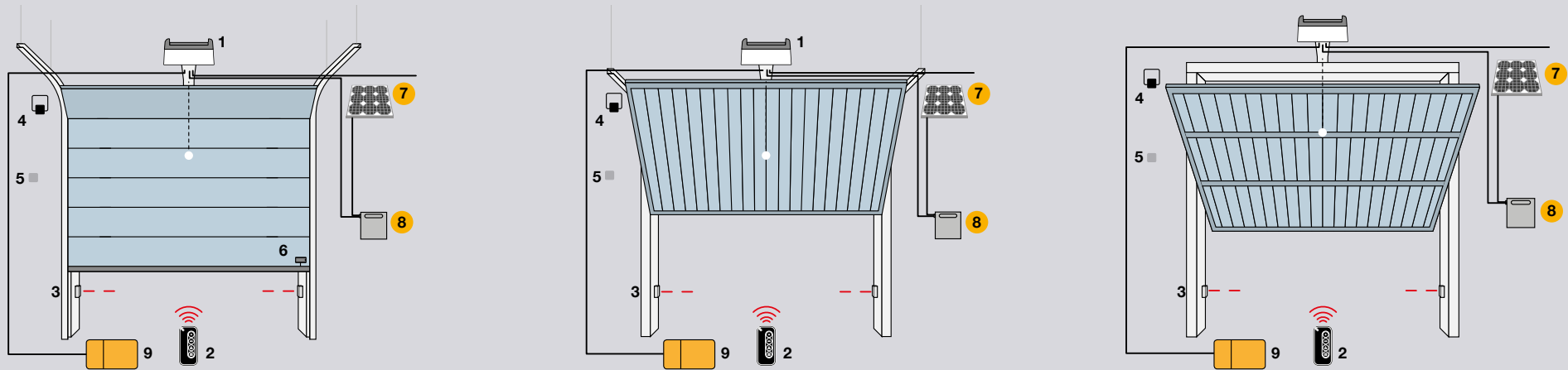
**SPIDER, SPIDO, SPINBUS**

1. Motor 2. Transmitter 3. Photocells 4. Flashing light 5. Key or digital switch  
6. Sensor for sensitive edge 7. SYP30 solar panel 8. PSY24 battery box 9. Pro-View multifunction interface

● Solemyo solar power accessories

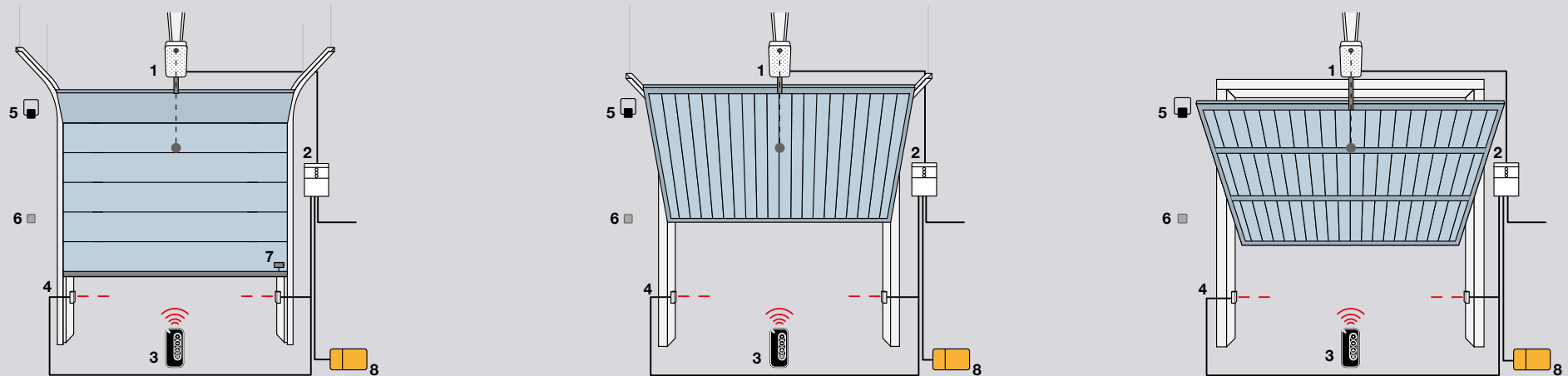
**SPYKIT 550**

1. Motor 2. Control unit 3. Transmitter 4. Photocells 5. Flashing light 6. Digital or key switch  
7. Sensor for sensitive edge 8. Pro-View multifunction interface

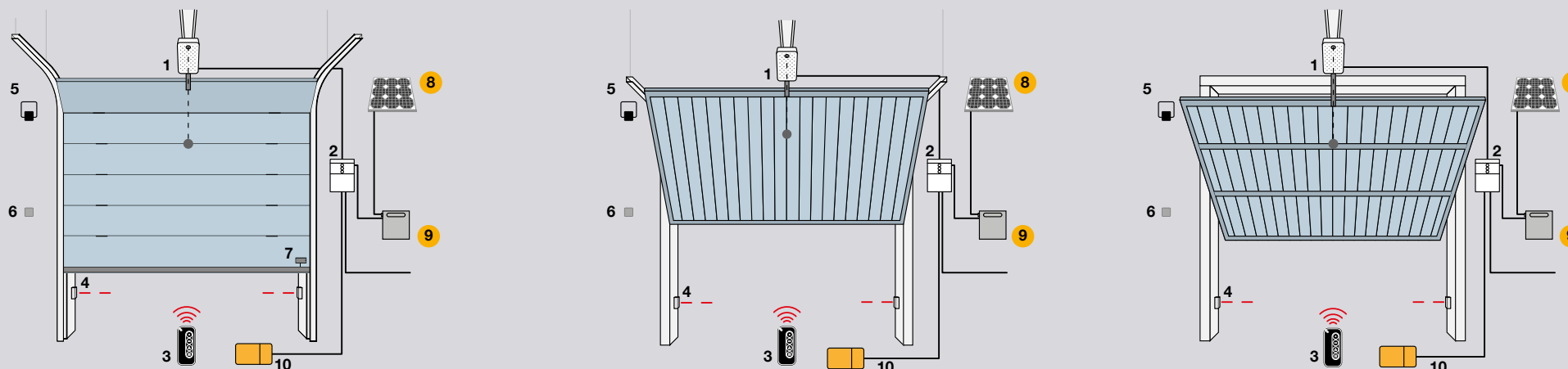

**SPYKIT 650/800 BD**

1. Motor 2. Control unit 3. Transmitter 4. Photocells 5. Flashing light 6. Digital or key switch  
7. Sensor for sensitive edge 8. SYP30 solar panel 9. PSY2 battery box 10. Pro-View multifunction interface

● Solemyo solar power accessories

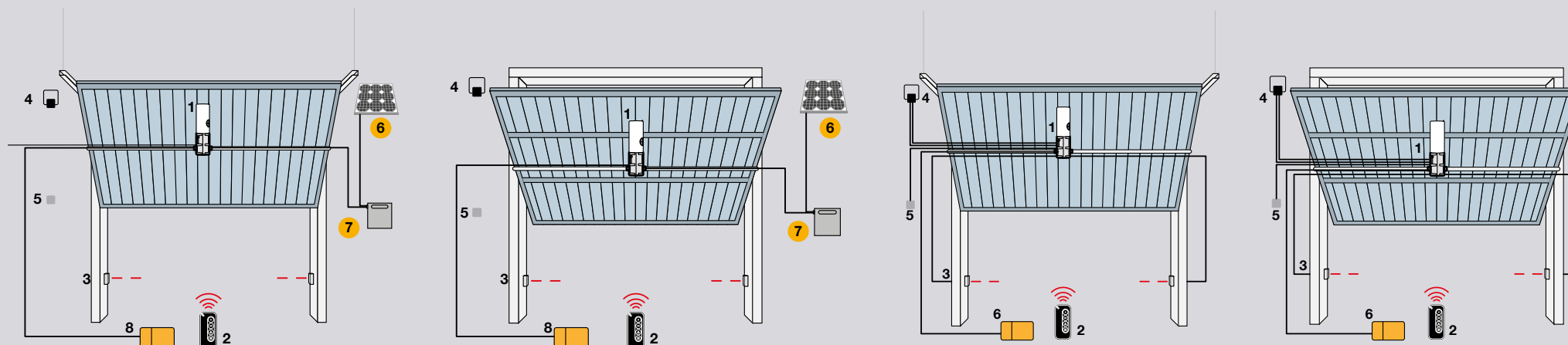

**TEN2010L**

1. Motor 2. Transmitter 3. Photocells 4. Flashing light 5. Key or digital switch  
6. SYP30 solar panel 7. PSY24 battery box 8. Pro-View multifunction interface

● Solemyo solar power accessories

**TEN2030L / TENKIT**

1. Motor 2. Transmitter 3. Photocells 4. Flashing light 5. Key or digital switch  
6. Pro-View multifunction interface

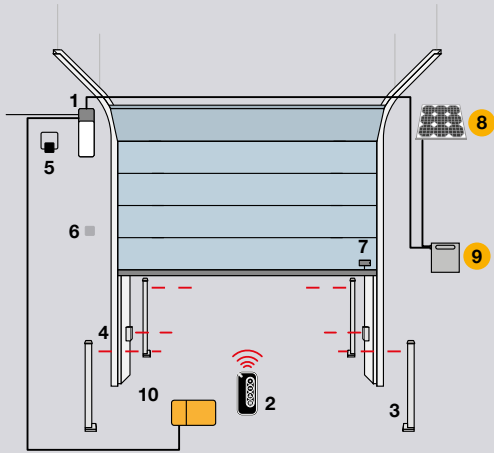

**SOON**

1. Motor 2. Transmitter 3. Post-mounted photocells 4. Photocells 5. Flashing light 6. Digital or key switch 7. Sensor for sensitive edge 8. SYP30 solar panel 9. PSY24 battery box 10. Pro-View multifunction interface

● Solemyo solar power accessories

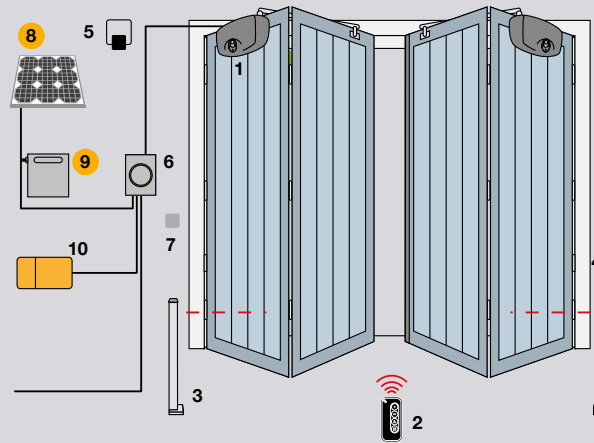

**HYPPO 7100**

1. Motor 2. Transmitter 3. Post-mounted photocells 4. Photocells 5. Flashing light 6. Control unit 7. Digital or key switch 8. SYP30 solar panel 9. PSY24 battery box (for HY7124 only) 10. Pro-View multifunction interface

● Solemyo solar power accessories

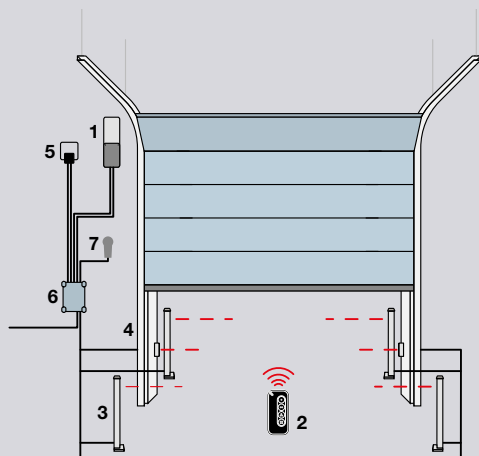

**SUMO**

1. Motor 2. Transmitter 3. Post-mounted photocells 4. Photocells 5. Flashing light 6. Control unit 7. Key or digital switch

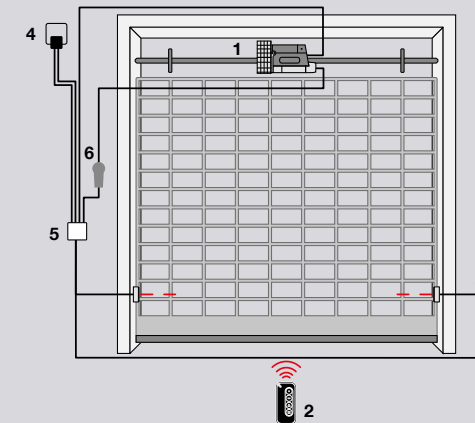
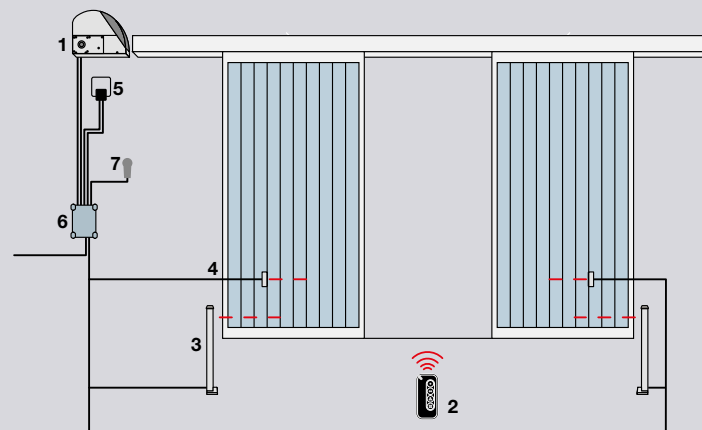

**RONDO**

1. Motor 2. Transmitter 3. Photocells 4. Flashing light 5. Control unit 6. Digital or key switch



Nice

# MyGO BD

## Bidirectional transmitters and receivers.

Command reception feedback

- Open
- Closed
- Partially open

EPD®

IES-0020012

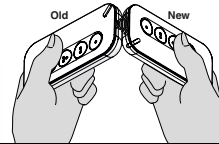

Enabling code exchanged between a previously stored transmitter and a new transmitter yet to be stored.



**MyGO BD transmitters with 433.92 MHz radio frequency with bidirectional encoding. Also compatible with Nice O-Code encoded receivers.**

### Smart Programming

The new MYGOBD remote controls can be programmed via the MyNice Pro app.

### Control

The installer can remotely activate an additional remote control through the Pro-View interface and MyNice Pro app or use a MYGOBD transmitter already enabled in the receiver.

The user can check the gate/garage door at any time with a simple click.

Each time a button is pressed on the MYGOBD transmitter, the user receives immediate confirmation of the successful command via a short vibration and a green info LED light.

Info LED flashes red to signal low battery during transmission.

### Performance

The bidirectional radio protocol uses GFSK modulation to ensure immunity from interference.

### Versatility

Available in three versions: 2, 4 and 8 buttons.

Code	Description	Pcs. Pack
<b>MYGO2BD</b>	2 channels, bidirectional, 433.92 MHz	10
<b>MYGO4BD</b>	4 channels, bidirectional, 433.92 MHz	10
<b>MYGO8BD</b>	8 channels, bidirectional, 433.92 MHz	10

### TECHNICAL SPECIFICATIONS

	Carrier frequency	Estimated range	Encoding	Power supply	Battery life	Protection rating	Dimensions Weight
<b>MYGOBD</b>	433.92 MHz	Up to 200 m, 500 m max (Mesh network); 35m (if inside a building)*	BD; O-Code	3 VDC; lithium battery CR2430	3 years (with 10 transmissions per day)	IP30	72x34x11 h mm 20 g

\* Transmitter range and receiver reception capacity may be affected by other devices in the area operating on the same frequency and by the position of the system's radio antenna.

BiDi

Yubii

Nice

# MyGO & MyGOFM

## Unidirectional transmitters and receivers.

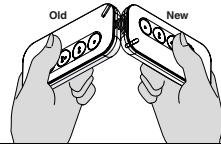

Enabling code exchanged between a previously stored transmitter and a new transmitter yet to be stored.



MYGO2  
MYGO2C



MYGO4  
MYGO4C



MYGO8  
MYGO8C



MYGO2FM



MYGO4FM

EPD®

IES-0020012

**MyGO transmitters with 433.92 MHz radio frequency with O-Code encoding.**

**MyGO FM transmitters, ideal for use in cities or places where multiple devices are installed:** 868.46 MHz versions, Rolling Code with FM frequency modulation, guarantee greater immunity to interference.

### Smart Programming

The new MYGO remote controls can be programmed via the MyNice Pro app.

The installer can pre-pair the remote controls to a plug-in receiver via the MyNice Pro app and the Pro-View multifunction interface. Save time during the installation. With sequential coding remote controls, pre-pairing can be done en masse for apartment blocks.

### Control

The installer can remotely activate an additional remote control through the Pro-View interface and MyNice Pro app or use a MYGO transmitter already enabled in the receiver.

Info LED flashes red to signal low battery during transmission.

### Versatility

Available in two versions: 2, 4 and 8 buttons as per customer requirements.

Code	Description	Pcs. Pack
<b>MYGO2</b>	2 channels, 433.92 MHz	10
<b>MYGO4</b>	4 channels, 433.92 MHz	10
<b>MYGO8</b>	8 channels, 433.92 MHz	10
<b>MYGO2C</b>	2 channels, 433.92 MHz, sequential coding for multiple insertion	10
<b>MYGO4C</b>	4 channels, 433.92 MHz, sequential coding for multiple insertion	10
<b>MYGO8C</b>	8 channels, 433.92 MHz, sequential coding for multiple insertion	10
<b>MYGO2FM</b>	2 channels, 868.46 MHz	10
<b>MYGO4FM</b>	4 channels, 868.46 MHz	10

### TECHNICAL SPECIFICATIONS

	Carrier frequency	Estimated range	Encoding	Power supply	Battery life	Protection class	Dimensions Weight
<b>MYGO</b>	433.92 MHz	200 m (outdoors); 35 m (if inside a building)*	O-Code	3 VDC; lithium battery CR2430	3 years (with 10 transmissions per day)	IP30	72x34x11 h mm 20 g
<b>MYGOFM</b>	868.46 MHz						

\* Transmitter range and receiver reception capacity may be affected by other devices in the area operating on the same frequency and by the position of the system's radio antenna.

Nice

# Era One LR & OXI LR

**Bidirectional transmitters and receivers with LoRa® technology.**

Command reception feedback

- Open
- Closed
- Partially open

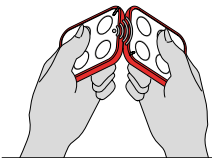

**Exchange of identity code** between a previously memorised transmitter and a new transmitter to be memorised.

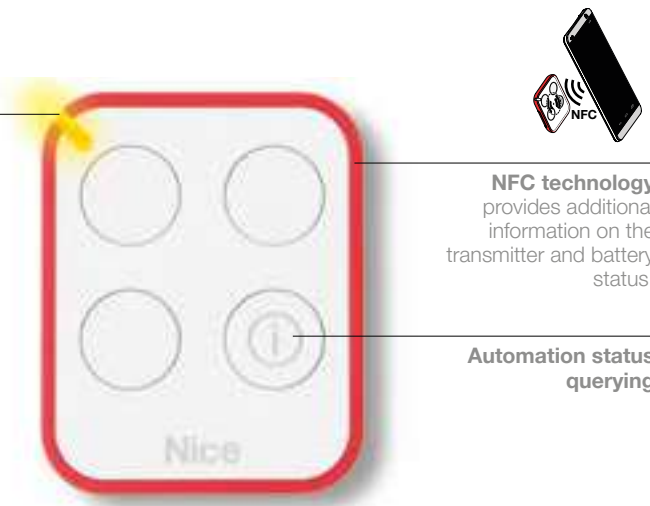

**NFC technology** provides additional information on the transmitter and battery status.

**Automation status querying**

**4 key transmitter: 3 radio channels and 1 key to interrogate automation status.**

433.92 MHz radio frequency with rolling code encoding, enabling code management, self-teaching.

**Long range commands:** LoRa® technology sends commands over a distance about 10 times greater than previous radio protocols. Automation control has never been so efficient!

**Even at a distance from the system,** you can enable a new transmitter by using another Era One LR transmitter already enabled in the receiver, thanks to **identity code** exchange between the two.

**Elegant and practical:** the Era One LR transmitter can be used as a refined high-tech keyring, or fixed to the wall or the car dashboard, thanks to the practical mount (**ONECLIPKIT**).

**Era One LR bidirectional, ideal for use in cities or places where there are numerous other devices present.**



The bidirectional radio protocol uses LoRa® modulation for greater immunity to interference.

**Plug-in bidirectional radio receiver with LoRa® technology.**

The OXILR is compatible with all Nice control units with SM connector, therefore it can also make existing Nice automations long range and bidirectional.

**Ergonomic design:** antenna connectors, key and programming LED in convenient practical positions.

**Maximum flexibility:** able to memorise up to 1,024 bidirectional transmitters with LoRa® technology.



**ONECLIPKIT**  
Kit with LoRa® technology for integrated installation in third party automations, thanks to the OX2UBP hardware interface.

BiDi

## TRANSMITTERS

Code	Description	Pcs./pack
<b>ON3ELR</b>	3 channels, 433.92 MHz, bidirectional, with LoRa® technology	10
<b>ONECLIPKIT</b>	White plastic clip with adhesive for wall mounting	10
<b>ONELRKIT</b>	KIT with LoRa® technology Contains: 2 x ON3ELR, 1 x OXILR, 1 x OX2UBP	1

## TECHNICAL SPECIFICATIONS

	Carrier frequency	Estimated range	Encoding	Power supply	Battery life	Protection class	Dimensions Weight
<b>ON3ELR</b>	433.92 MHz	1 Km; 100 m (if inside a building)*	LR	3 VDC; CR2032 lithium battery	2 years (with 10 transmissions per day)	IP40 (use in protected environments)	45x56x11 h mm 18 g

\* Transmitter range and receiver reception capacity may be affected by any other devices operating on the same frequency in the area and by the position of the system's radio antenna.

## RECEIVERS

Code	Description	Pcs./pack
<b>OXILR</b>	Plug-in bidirectional 433.92 MHz radio receiver with LoRa® technology	1

## TECHNICAL SPECIFICATIONS

	Reception frequency	Trans-mission frequency	Input im-pedance	Sensitivity	Encoding	Number of channels	Power supply	Draw	Protection class	Dimensions Weight
<b>OXILR</b>	433.92 MHz	433.92 MHz	50 Ohm	-118 dBm	LR	4 (on "SM" plug-in connector)	5 VDC	50 mA (max)	IP 30	49.5x18x41.9 h mm 22 g



Nice

# Era Inti

## Transmitters.

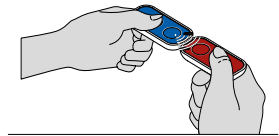

**Exchange of identity code** between a previously memorised transmitter and a new transmitter to be memorised.

### Colourful range of mini transmitters, 2 channels, available in six colours.

433.92 MHz, rolling code, identity code and certificate management, self-learning and integrated proximity receiver; with 72 bit O-Code encoding, also compatible with receivers with Nice FloR encoding.

**Advanced:** uses calculation and recognition systems to increase security grade and reduce the automation response time by about 3.

**Safe:** if a transmitter is stolen or lost, it can be replaced via the Pro-View multifunction interface and MyNice Pro App, maintaining the same functions as before; the old transmitter can be disabled by increasing the priority level on the new Inti.

### Practical to memorise, even remotely: thanks to the Opera receivers.

**Without having to be near the system**, you can enable a new transmitter in two different ways:

- using a transmitter already enabled in the receiver, thanks to **identity code** exchange between the two;
- via the Pro-View multifunction interface and MyNice Pro App, by placing the new transmitter on the interface and entering the **Certificate** of the receiver to be paired with the new transmitter. The receiver's **Certificate** can be viewed in the corresponding installation available on the Nice Cloud.

**Inti can also be used as a key-ring, thanks to the cord included in the pack.**

### Ideal for apartment blocks and multi-user installations.

Easy and inexpensive installation: combined with the OX2 universal receiver, the Inti transmitter can control and manage any new or existing automation system.

Code	Description	Pcs. Pack
<b>INTI2Y</b>	2 channels, 433.92 MHz, yellow	10
<b>INTI2R</b>	2 channels, 433.92 MHz, red	10
<b>INTI2L</b>	2 channels, 433.92 MHz, colour lilac	10
<b>INTI2G</b>	2 channels, 433.92 MHz, colour green	10
<b>INTI2B</b>	2 channels, 433.92 MHz, colour blue	10
<b>INTI2</b>	2 channels, 433.92 MHz, colour black	10
<b>INTIKIT</b>	Kit consisting of: 3 x 2-channel Inti (red, green, blue), 1 x OX2 receiver	10

**TECHNICAL SPECIFICATIONS**

	Carrier frequency	Estimated range	Encoding	Power supply	Battery life	Protection class	Dimensions Weight
<b>INTI2Y, INTI2R, INTI2L, INTI2G, INTI2B, INTI</b>	433.92 MHz	150 m (outdoors); 30 m (if inside a building) a building)*	72 bit O-Code; rolling code	3 VDC; CR2032 lithium battery	2 years (with 10 transmissions per day)	IP40 (use in protected environments)	30x56x9 h mm 14 g

\* Transmitter range and receiver reception capacity may be affected by any other devices operating on the same frequency in the area and by the position of the system's radio antenna.



**Nice Intikit**



Nice

# Era One

## Transmitters and receivers.

Soon to be discontinued



**Exchange of identity code** between a previously memorised transmitter and a new transmitter to be memorised.

**Plug-in 2-, 4-channel transmitters and receivers, pre-wired, with and without built-in transmitter.**

433.92 MHz, rolling code, identity code and certificate management, self-learning and integrated proximity receiver; with 72 bit O-Code encoding, also compatible with receivers with Nice FloR encoding.

Also available in versions with sequential coding for multiple insertion (Era OneC).

**Advanced:** uses calculation and recognition systems to increase security grade and reduce the automation response time by about 3.

**Practical to memorise, even remotely:** thanks to the Opera receivers.

**Safe:** if a transmitter is stolen or lost, it can be replaced via the Pro-View multifunction interface and MyNice Pro App, maintaining the same functions as before; the old transmitter can be **disabled** by increasing the priority level on the new Era One.

**Without having to be near the system,** you can enable a new transmitter in two different ways:

- using a transmitter already enabled in the receiver, thanks to **identity code** exchange between the two;
- via the Pro-View multifunction interface and MyNice Pro App, by placing the new transmitter on the interface and entering the **Certificate** of the receiver to be paired with the new transmitter. The receiver's **Certificate** can be viewed in the corresponding installation available on the Nice Cloud.

**Practical:** via the Pro-View multifunction interface and MyNice Pro App, the Era OneC version can store entire packs of 10 in a single operation, without having to open them.

**Convenient:** the Era One transmitter can be used as a keyring, or fixed to the wall or car dashboard, thanks to the practical **ONECLIP-KIT** mount.

Code	Description	Pcs. Pack
<b>ON2E</b>	2 channels, 433.92 MHz	10
<b>ON4E</b>	4 channels, 433.92 MHz	10
<b>ON2CE</b>	2 channels, 433.92 MHz, with sequential coding for multiple insertion	10
<b>ON4CE</b>	4 channels, 433.92 MHz, with sequential coding for multiple insertion	10
<b>ONECLIPKIT</b>	White plastic support clip with adhesive for wall mounting	10

### TECHNICAL SPECIFICATIONS

	Carrier frequency	Estimated range	Encoding	Power supply	Battery life	Protection class	Dimensions Weight
<b>ON_E, ON_CE</b>	433.92 MHz	200 m (outdoors); 35 m (if inside a building)*	72 bit O-Code; rolling code	3 VDC; CR2032 lithium battery	2 years (with 10 transmissions per day)	IP40 (use in protected environments)	45x56x11 h mm 18 g

\* Transmitter range and receiver reception capacity may be affected by any devices operating on the same frequency in the area.

Nice

# DOMÌ W3C

## Wall-mounted 3-channel bidirectional radio transmitter.

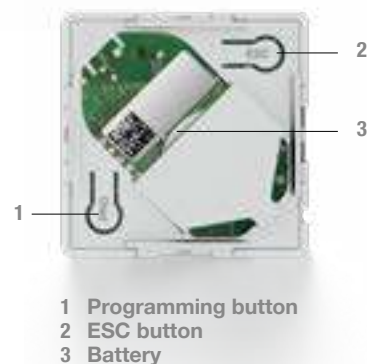
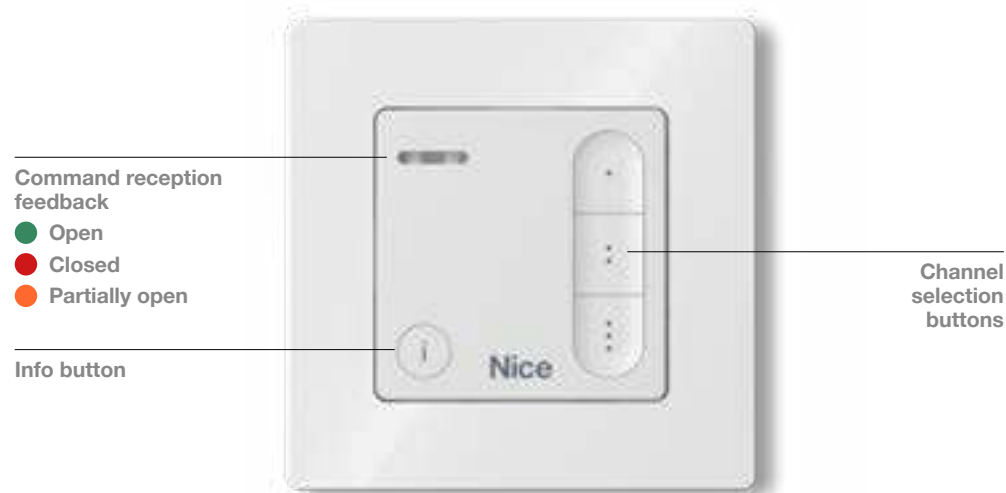

BiDi

Yubii

### DOMÌ W3C is a wall-mounted 3-channel bidirectional radio transmitter.

With DOMÌ W3C you can:

- control up to 3 different automations simultaneously;
- check the garage door using three different commands when you don't have a transmitter to hand; for example, you can store 1 button for switching on the light built into the garage door motor.

### Performance

use the info button to check your gate/garage door at any time with a simple click.

### Each wall-mounting with no wiring necessary.

### Design

The DOMÌ wall-mounted transmitter includes an operating unit and a standard 50 x 50 mm frame.



Code	Description	Pcs. Pack
<b>DOMIW3C</b>	Wall-mounted bidirectional transmitter, three channels, white	1

### TECHNICAL SPECIFICATIONS

Code	<b>DOMIW3C</b>
Battery type (V)	3 (1 x CR2450 lithium)
Battery life (years)	~ 3 (with 10 transmissions per day)
Radio frequency (MHz)	433,92
Transmitter RF power (ERP)	≤ 10 dBm
Radio coding	BD / O-Code
Operating ambient temperature (°C)	-5 ÷ 55
Relative humidity	max. 85% (not for humid environments, non-condensing)
Protection class (IP)	40
Weight incl. batteries (g)	24
Dimensions (mm)	50x50x13
Installation (optional)	wall-mounted
Conformity	<b>CE</b>

Nice

# Receivers

## MYGO, Era Inti, One.

**The complete line of receivers with Opera system functions, suitable for every system requirement:**

- **plug-in**, compatible with Nice control units with SM type connector and third-party control units thanks to the OX2UBP hardware interface.
- **universal pre-wired**, for combination with all types of control unit, to manage any automation, lighting or irrigation system or other electrical circuit.

**Maximum flexibility:** can memorise up to 1024 transmitters.

**Practical and functional:** the presence of a transmitter inside OX2T and OX4T receivers provides access to radio codes via the Pro-View multifunction interface and MyNice Pro App, even when they are in a hard-to-reach position.

OX2T and OX4T receivers can be used as signal repeaters to increase the operating distance between the transmitters and other One series receivers.

**Secure management**, thanks to 3 levels of password and key protection.

**Multi-user systems management:** thanks to the unique, personal code: the self-learning receivers can receive and memorise up to 256 codes.

**Memorising:** each key of the transmitter can be associated with a particular receiver output (e.g. key 3 TX = output 1 RX).

### 433.92 MHz RECEIVER, WITH OPERA SYSTEM FUNCTIONS

Code	Description	Pcs./pack
<b>PLUG-IN</b>		
<b>OXIBD</b>	Plug-in radio receiver, unidirectional and bidirectional, 433.92 MHz	1

### UNIVERSAL PRE-WIRED

<b>OX2</b>	2 channels, without built-in transmitter	1
<b>OX2T</b>	2 channels, with built-in transmitter	1
<b>OX4T</b>	4 channels, with built-in transmitter	1

### HARDWARE INTERFACE

<b>OX2UBP</b>	Universal hardware interface for OXI series plug-in receivers 433,92 MHz and 866,46 MHz	1
---------------	---	---



OXIBD

OX2, OX2T

OX4T

OX2UBP

### 868.46 MHz RECEIVER, WITH OPERA SYSTEM FUNCTIONS

Code	Description	Pcs./pack
<b>PLUG-IN</b>		
<b>OXIOFM</b>	4 channels radio receiver	1



OXIOFM

### PROFESSIONAL ADJUSTABLE TUNED ANTENNAS

Code	Description	Pcs./pack
<b>ABF</b>	Bracket mounting	1

**TECHNICAL SPECIFICATIONS OPERA COMPATIBLE RECEIVERS**

Code	Reception frequency (MHz)	Transmission frequency (MHz)	Input impedance (Ohm)	Sensitivity	Encoding	Number of channels	Relay contact	Power supply	Draw	Protection class	Dimensions (mm)	Weight (g)
<b>OXIBD</b>	433,92	433.92 MHz (BD only)	50	-108 dBm	BD, O-Code, FloR, TTS, Flo, Smilo	4 (on "SM" plug-in connector)	-	5 VDC	50 mA (max)	IP 30	49.5x18x41.9 h	22
<b>OX2</b> <b>OX2T</b>		-	52	>0.5 $\mu$ V for successful signal	O-Code, FloR, Flo	2	max. 0.5 A 50 V (NO)	12 to 28 VDC/ VAC	80 mA (max.) with active relays		58x86x22 h	55
<b>OX4T</b>		433,92				4 relays with potential free NO and NC contacts	5A - 250V	110-240 VAC 50/60 Hz	80 mA	IP 44 (with undamaged case)	128x112x43 h	260
<b>OXIOFM</b>	868,46	-	50	-108 dBm	O-Code	4 (on "SM" plug-in connector)	-	5 VDC	50 mA (max)	IP 30	49.5x18x41.9 h	22

**TECHNICAL SPECIFICATIONS ACCESSORIES**

Code	Reception frequency (MHz)	Impedance (Ohm)	Bracket	Cable
<b>ABF</b>	433,92	50	stainless steel	RG 58

Nice

# OX4T

One series 4-channel universal receiver with built-in transmitter.



For remote control of any automation for gates, garage doors, barriers, rolling doors, rolling shutters, Venetian blinds, lighting systems, irrigation systems or other electrical circuits.

**With BUS T4 connector for connection with Pro-View.**

**The most extensive system:** The OX4T manages 4 relay-controlled outputs, usable as power relays or dry outputs, extending the Opera system to devices without compatible with Opera.

Thanks to the internal transmitter, the OX4T can be used as a repeater, increasing the operating distance between transmitters and other One series receivers.

**Practical and functional:** OX4T can be connected via radio to the O-Box interface and via BUS T4 to the Pro-View multifunction display to perform programming, diagnostics, timing and code management operations, including remotely via the OVBT and OVBTGSM modules.

**2 programming modes:** "Mode I" and the new "Extended Mode II" allowing the number of commands to be increased to 14.

**Multicode:** OX4T is also compatible with O-code, Smilo, Flo, FloR, FloR TTS encoded transmitters.

The OX4T has a large memory able to memorise up to 1024 transmitters and can be password protected.

Code	Description	Pcs. Pack
<b>OX4T</b>	Universal 4-channel receiver with built-in transmitter	1

## TECHNICAL SPECIFICATIONS

Power supply (VAC 50/60 Hz)	110 ÷ 240
Maximum current draw (mA)	80
Encoding	O-Code / TTS / FloR (rolling code); or Smilo (rolling code) or Flo
Frequency (MHz)	433,92
Antenna impedance (Ohm)	More than 0.5 for successful signal
Estimated range (m)	200 m in open space, 35 m indoors
Radiated power (Dbm)	2
Maximum no. transmitters memorisable	1024 (maximum)
Outputs	4 relays with potential free NO and NC contacts
Contact rating	5A - 250V
Timer time	Programmable from 2 seconds to 540 minutes
Protection class (IP)	44 (with undamaged case)
Operating temperature (°C Min/Max)	From -20° to +55°
Dimensions (mm)	128x112x43 h
Weight (g)	260

Opera

Nice

# Nice Era photocells, selectors & proximity reader

The Nice generation of optical devices for automation safety, available with Nice BlueBUS technology for simplified installation.

Three different sizes of synchronised photocells to satisfy all needs and complete the safety and convenience of every automation system, even in the narrowest spaces; perfect for refurbishments to cover unwanted existing installations.

## SLIM

Only 30 mm wide, ideal in narrow spaces.



## ERA KEYPAD

Ultra-sturdy metal body with a depth of 27 mm, protrudes from the wall by just 13 mm in the recessed version.



## DIGITAL WIRELESS SWITCH (EDSWG)

Anti-intrusion digital switch with 13 keys.



## DIGITAL SWITCHES (EDS)

Anti-intrusion surface mounted or recessed digital switches.

## MEDIUM

Reflective and adjustable versions, ideal for the commonest systems.



## ERA KEY

Extra-thin: protrudes from the wall by just 13 mm in the recessed versions.



## KEY SWITCHES WITH EUROPEAN CYLINDER (EKSU)

Key switches in surface mounted or recessed version.



## KEY SWITCHES WITH STANDARD CYLINDER (EKS)

Key switches in surface mounted or recessed version.

## LARGE

Adjustable, also in the recessed version protruding by 9 mm, ideal for concealed installation.



## ERA TRANSPONDER READER

Proximity readers for transponder cards and badges with personalised programming.



## PROXIMITY READERS (ETP)

Proximity readers for reading cards and badges.



## TRANSPONDER BADGES

Convenient transponder badge with practical hole for attaching to a keyring.

Nice

# Era Photocell S

**Fixed synchronised Slim photocells, including with Nice BlueBUS technology.**



EPS  
EPSB

**Safe:** type D device in accordance with EN12453 able to detect obstacles in the optical axis between the transmitter (TX) and receiver (RX).

Using the phototest function, it is possible to achieve fault safety category 2 according to EN 954-1.

An anti-glare circuit eliminates possible interference from sunlight.

**Practical:** 8° reception angle.

**Resistant, also in anti-intrusion version:** weather-resistant ABS body, also available in anti-intrusion version with metal body.

**Nice BlueBUS technology:** available with the Nice BlueBUS system, allowing easy connection to the control unit of all devices with just two wires, simply by connecting them in parallel and selecting the addressing jumpers according to the required function. The system automatically acquires devices connected to the BlueBUS network.

Automatic synchronisation between several pairs of photocells to avoid other interference between devices.

**IB interface:** allows connection of presence detectors with Nice BlueBUS technology to control units with inputs for traditional contacts.

**PHOTOCELLS**

Code	Description	Pcs./pack
<b>EPS</b>	Pair of Slim surface mounted photocells	1

**PHOTOCELLS WITH NICE BLUEBUS TECHNOLOGY**

Code	Description	Pcs./pack
<b>EPSB</b>	Pair of Slim surface mounted photocells, for connection via Nice BlueBUS	1
<b>IB</b>	Interface for connecting BlueBUS photocells to control units without BlueBUS system	1

**TECHNICAL SPECIFICATIONS**

	Estimated range (m)	Power supply	Draw (mA)	Protection class (IP)	Operating temperature (°C min./max.)	Relay range	Dimensions (mm)	Weight (g)
<b>EPS</b>	15	24 VAC/VDC limits: 18-35 VDC, 15-28 VAC	25 RX, 30 TX	44	-20 ÷ +50	max. 500 mA and 48 V	30x27x106 h	120

**TECHNICAL SPECIFICATIONS WITH NICE BLUEBUS TECHNOLOGY**

	Estimated range (m)	Power output	Protection class (IP)	Operating temperature (°C min./max.)	Dimensions (mm)	Weight (g)
<b>EPSB</b>	up to 15 for maximum TX-RX offset ± 5 (the device can signal an obstacle even in adverse weather conditions)	the device can only be connected to "BlueBUS" networks, from which it receives power and transmits the output signals	44	-20 ÷ +50	30x27x106 h	120

	Power supply	Draw with 24 VDC power supply	Draw with 24 VAC power supply	BlueBUS output	Protection class (IP)	Operating temperature (°C min./max.)	Dimensions (mm)	Weight (g)
<b>IB</b>	16 - 35 VDC 18 - 28 VAC	50 mA (add approx. 50 mA for each pair of photocells)	44 mA (add approx. 40 mA for each pair of photocells)	one with a max. load of 9 BlueBUS units	30	-20 ÷ +50	86x58x22 h	72

**IB**

Nice

# Era Photocell M

**Fixed or adjustable synchronised Medium photocells, including with Nice BlueBUS technology.**



EPM  
EPMB



EPMO  
EPMOB



EPMA  
EPMAB



EPMO  
EPMO B



EPMOR  
EPMORB



Available in reflective and wireless versions.

**Safe:** type D device in accordance with EN12453 able to detect obstacles in the optical axis between the transmitter (TX) and receiver (RX).

Using the phototest function, it is possible to achieve fault safety category 2 according to EN 954-1.

An anti-glare circuit eliminates possible interference from sunlight.

**Fast easy installation:** thanks to the reflective technology (EPMOR- EPMORB), just the main photocell needs to be wired and not the reflective mirror, saving time.

**Integrated LED light in the EPMOR - EPMORB version:** the optional ELMM LED light module can be installed in the EPMOR photocell to illuminate the transit area, act as a flashing light or provide diagnostic indications.

**Universal system:** EPMOR and EPMORB have a relay output for connection to any new or existing automation system.

**Practical:** 10° reception angle. The adjustable versions allow up to 30° compensation for centring differences.

**Resistant:** weather-resistant ABS body, also available with metal body.

**Nice BlueBUS technology:** available with the Nice BlueBUS system, allowing easy connection to the control unit of all devices with just two wires, simply by connecting them in parallel and selecting the addressing jumpers according to the required function. The system automatically acquires devices connected to the BlueBUS network.

Automatic synchronisation between several pairs of photocells to avoid other interference between devices.

BlueBus

## PHOTOCELLS

Code	Description	Pcs./pack
<b>EPM</b>	Pair of surface mounted photocells	1
<b>EPMO</b>	Pair of surface mounted photocells, adjustable through 30°	1

## PHOTOCELLS WITH NICE BLUEBUS TECHNOLOGY

Code	Description	Pcs./pack
<b>EPMB</b>	Pair of surface mounted photocells, for connection via Nice BlueBUS	1
<b>EPMOB</b>	Pair of surface mounted photocells, adjustable through 30°, for connection via Nice BlueBUS	1

## PHOTOCELLS WITH REFLECTIVE TECHNOLOGY

Code	Description	Pcs./pack
<b>EPMOR</b>	Surface mounted reflective photocell + reflective mirror	1

## REFLECTIVE PHOTOCELLS WITH BLUEBUS TECHNOLOGY

Code	Description	Pcs./pack
<b>EPMORB</b>	Surface mounted reflective photocell with Nice BlueBUS technology + reflective mirror	1

## TECHNICAL SPECIFICATIONS

	Estimated range (m)	Power supply	Draw (mA)	Photocell adjustability	Protection class (IP)	Operating temperature (°C min./max.)	Relay range	Dimensions (mm)	Weight (g)
<b>EPM</b>	15 (30 with jumper + "10" cut)	without 24 VAC/VDC jumper limits: 18-35 VDC, 15-28 VAC with 12 VAC/VDC jumper limits: 10-18 VDC, 9-15 VAC	25 RX, 30 TX	-	44	-20 ÷ +50	max. 500 mA and 48 V	50x29x80 h	140
<b>EPMO</b>				approx. 30° on all axes				50x38x80 h	160
<b>EPMOR</b>	8 (maximum range in optimum conditions 15)	12-24 V	50	approx. 10° on all axes				50x40x105 h	83

## TECHNICAL SPECIFICATIONS WITH NICE BLUEBUS TECHNOLOGY

	Estimated range (m)	Power output	Photocell adjustability	Protection class (IP)	Operating temperature (°C Min/Max)	Dimensions (mm)	Weight (g)
<b>EPMB</b>	up to 15 for maximum TX-RX offset ± 5 (the device can signal an obstacle even in adverse weather conditions)	the device can only be connected to "BlueBUS" networks, from which it receives power and transmits the output signals	-	44	-20 ÷ +55	50x29x80 h	140
<b>EPMOB</b>			approx. 30° on all axes			50x38x80 h	160
<b>EPMORB</b>			8 (maximum range in optimum conditions 15)			-	50x40x105 h

	Power supply	Draw with 24 VDC power supply	Draw with 24 VAC power supply	BlueBUS output	Protection class (IP)	Operating temperature (°C min./max.)	Dimensions (mm)	Weight (g)
<b>IB</b>	16 - 35 VDC 18 - 28 VAC	50 mA (add approx. 50 mA for each pair of photocells)	44 mA (add approx. 40 mA for each pair of photocells)	one with a max. load of 9 BlueBUS units	30	-20 ÷ +50	86x58x22 h	72

	Power supply	Power draw (W)	Protection class (IP)	Operating temperature (°C min./max.)	Dimensions (mm)	Weight (g)
<b>ELMM</b>	12-24 V	1	45	-20 ÷ +55	40 x 30 x 25 h	20

## ACCESSORIES

Code	Description	Pcs./pack
<b>IB</b>	Interface for connecting BlueBUS photocells to control units without BlueBUS system	1
<b>ELMM</b>	LED light module for EPMOR	1
<b>POE</b>	Wall support for Era photocells	1



IB

ELMM

POE

Nice

# Era Photocell L

**Fixed or adjustable Large photocells, including with Nice BlueBUS technology, both surface mounted and recessed.**

**Easy and versatile:** EPLIO recessed versions are compatible with the most popular standards on the market to replace old photocells or cover unwanted existing installations without the need for any additional adapter.

**Safe:** type D device in accordance with EN12453 able to detect obstacles in the optical axis between the transmitter (TX) and receiver (RX).

Using the phototest function, it is possible to achieve fault safety category 2 according to EN 954-1.

EPL, EPLO and EPLIO models provide 2 range levels.

An anti-glare circuit eliminates possible interference from sunlight.

The adjustable versions allow up to 30° compensation for centring differences.

**Inconspicuous:** ultra-sturdy polycarbonate body, protrudes for a minimum of 9 mm from the wall in the recessed version.

**Convenient:** EKA03 bowl adapter for convenient recessed mounting.

**Nice BlueBUS technology:** the versions with Nice BlueBUS system allow easy connection to the control unit of all devices with just two wires, simply by connecting them in parallel and selecting the addressing jumpers according to the required function.

The system automatically acquires devices connected to the BlueBUS network and allows automatic synchronisation between several pairs of photocells to avoid other interference.

**IB interface:** allows connection of photocells with Nice BlueBUS technology to control units with inputs for traditional contact.



EPL  
EPLB



EPLO  
EPLOB



EPLIO  
EPLIOB

BlueBus

**PHOTOCELLS**

Code	Description	Pcs./pack
<b>EPL</b>	Pair of Large surface mounted photocells	1

**PHOTOCELLS WITH NICE BLUEBUS TECHNOLOGY**

Code	Description	Pcs./pack
<b>EPLB</b>	Pair of Large surface mounted photocells, for connection via Nice BlueBUS	1

**ADJUSTABLE PHOTOCELLS**

Code	Description	Pcs./pack
<b>EPLO</b>	Pair of Large surface mounted photocells, adjustable through 30°	1

**ADJUSTABLE PHOTOCELLS WITH NICE BLUEBUS TECHNOLOGY**

Code	Description	Pcs./pack
<b>EPLOB</b>	Pair of Large surface mounted photocells, adjustable through 30°, for connection via Nice BlueBUS	1

**ADJUSTABLE RECESSED PHOTOCELLS**

Code	Description	Pcs./pack
<b>EPLIO</b>	Pair of Large recessed photocells, adjustable through 30°	1

**ADJUSTABLE RECESSED PHOTOCELLS WITH NICE BLUEBUS TECHNOLOGY**

Code	Description	Pcs./pack
<b>EPLIOB</b>	Pair of Large recessed photocells, adjustable through 30°, for connection via Nice BlueBUS	1

**TECHNICAL SPECIFICATIONS**

	Estimated range (m)	Power supply	Photocell adjustability	Draw (mA)	Protection class (IP)	Operating temperature (°C min./max.)	Relay range	Dimensions (mm)	Weight (g)
<b>EPL</b>	15 (30 with jumper + "10" cut)	without 24 VAC/VDC jumper limits: 18-35 VDC, 15-28 VAC with 12 VAC/VDC jumper limits: 10-18 VDC, 9-15 VAC	-	25 RX, 30 TX	44	-20 ÷ +50	max. 500 mA and 48 V	70x30x70 h	160
<b>EPLO</b>								70x38x70 h	180
<b>EPLIO</b>			approx. 30° on all axes					70x66+9x70 h	185

**TECHNICAL SPECIFICATIONS WITH NICE BLUEBUS TECHNOLOGY**

	Estimated range (m)	Power output	Photocell adjustability	Protection class (IP)	Operating temperature (°C Min/Max)	Dimensions (mm)	Weight (g)
<b>EPLB</b>	up to 15 for maximum TX-RX offset ± 5 (the device can signal an obstacle even in adverse weather conditions)	the device can only be connected to "BlueBUS" networks, from which it receives power and transmits the output signals	-	44	-20 ÷ +50	70x30x70 h	140
<b>EPLOB</b>						70x38x70 h	160
<b>EPLIOB</b>			approx. 30° on all axes			70x66+9x70 h	185

	Power supply	Draw with 24 VDC power supply	Draw with 24 VAC power supply	BlueBUS output	Protection class (IP)	Operating temperature (°C min./max.)	Dimensions (mm)	Weight (g)
<b>IB</b>	16 - 35 VDC 18 - 28 VAC	50 mA (add approx. 50 mA for each pair of photocells)	44 mA (add approx. 40 mA for each pair of photocells)	one with a max. load of 9 BlueBUS units	30	-20 ÷ +50	86x58x22 h	72

**ACCESSORIES**

Code	Description	Pcs./pack
<b>IB</b>	Interface for connecting BlueBUS photocells to control units without BlueBUS system	1
<b>EKA03</b>	Bowl for recessed mounting (depth 66 mm) for installing EKSI, EKSIU. Also compatible with EPLIO, EPLIOB, EDSI, EDSIB	50
<b>POE</b>	Wall support for Era photocells	1

**IB****POE**

Nice

# Era Keypad

12-key digital switch, also with Nice BlueBUS connection technology, available in recessed version.



EDS  
EDSB



EDSI  
EDSIB

**Extra-thin:** ultra-sturdy 27 mm deep metal body, protruding by just 13 mm from the wall in the recessed version.

**Safe:** the combination is a number consisting of 1 to 9 digits, this allows 999,999,999 possible combinations to be generated!

Backlit keyboard.

**Easy to programme:**

- 2 programming modes: Easy or Professional;
- the number of times a specific card/badge can be used can be programmed;
- 255 memorisable combinations expandable on EDS and EDSI up to 510 combinations with BM1000 additional second memory.

**Nice BlueBUS technology:** available with the Nice BlueBUS system, allowing easy connection to the control unit of all devices with just two wires, simply by connecting them in parallel and other exclusive functions:

- 2 keys to activate two different commands chosen from the 6 available (e.g. step-by-step, close, open), depending on the control unit to which they are connected;
  - up to 4 EDSB/EDSIB and ETPB control devices can also be connected in a mixed configuration;
  - an automation lock/unlock can be added.
- Two different visual signals** depending on automation status:
- red, when the automation is closed or during the closing manoeuvre;
  - green, during the opening manoeuvre or if the “automation lock” function is active.

## DIGITAL SWITCHES

Code	Description	Pcs./pack
EDS	Digital switch, 12 keys, to combine with MORX Decoder	1
EDSI	Digital switch, 12 keys, recessed, to combine with MORX decoder	1
MORX	Decoder for 1 ETP or up to 4 EDS/EDSI connected in parallel, with 1 BM1000 memory for 255 combinations	1

## TECHNICAL SPECIFICATIONS

	Protection class (IP)	Dimensions (mm)	Weight (g)
EDS	44	70x27x70 h	200
EDSI	54	70x66+13x70 h	160

	Memory capacity	Relay range	Power supply	Maximum draw	Protection class (IP)	Operating temperature (°C min./max.)	Dimensions (mm)	Weight (g)
MORX	2 BM1000 for max. 510 combinations or 510 MOCARD, MOCARDP and HSB1	max. 500 mA and 48 VAC/VDC	10 - 35 VDC, 12 - 28 VAC	24 VDC=70 mA 24 VAC=200 mA 12 VDC=150 mA 12 VAC=300 mA with 1 ETP or up to 4 EDS/EDSI	30	-20 ÷ +70	98x42x25 h	65



MORX

## DIGITAL SWITCHES WITH NICE BLUEBUS TECHNOLOGY

Code	Description	Pcs./pack
EDSB	Digital 12-key switch with Nice BlueBUS technology, anti-intrusion metal body	1
EDSIB	Digital 12-key switch with Nice BlueBUS technology, recessed, anti-intrusion metal body	1

## TECHNICAL SPECIFICATIONS WITH NICE BLUEBUS TECHNOLOGY

	Power supply	Draw	Protection class (IP)	Dimensions (mm)	Weight (g)
EDSB	via BlueBUS	1.5 BlueBUS unit	44	70x27x70 h	200
EDSIB			54	70x66+13x70 h	160

## ACCESSORIES FOR RECESSED VERSIONS

Code	Description	Pcs./pack
EKA03	Bowl for recessed mounting (depth 66 mm) for installing EKSII, EKSIEU. Also compatible with EPLIO, EPLIOB, EDSI, EDSIB	50
EKA02	Finishing kit for installing EDSI, EDSIB, EKSII, EKSIEU	10

Nice

# Era Keypad wireless

13-key digital switches, with radio link for wireless connections.



## Radio controlled digital selector with

**Opera Radio coding protocol:** compatible with FloR receivers with rolling code encoding and generates 4.5 million billion combinations, self-teaching.

**Complete:** 3 transmission channels to control 3 automations or for 3 different personalised commands for a single automation.

**Convenient:** no wiring required and an estimated range of 25 m in open space and 15 m inside a building.

Backlit keypad in poor light conditions.

Acoustic feedback.

**Safe:** the combination is a number consisting of 1 to 9 digits, this allows 999,999,999 possible combinations to be generated!

**Economical:** ultra-low power consumption, transmission is activated at the press of a key, automatic turn-off.

The ambient light sensor activates the keyboard illumination only when necessary.

**Slim:** ultra-sturdy metal body, just 27 mm deep.

## DIGITAL WIRELESS SWITCH

Code	Description	Pcs./pack
<b>EDSWG</b>	Digital switch via radio compatible with Flor three-channel receivers, three passwords	1

## TECHNICAL SPECIFICATIONS

	Power supply	Battery life	Frequency	Radiated power	Radio coding	Operating temperature (°C min./max.)	No. combination digits	Estimated range (m)	Protection class (IP)	Dimensions (mm)	Weight (g)
<b>EDSWG</b>	6 VDC with 2 x CR2430 lithium batteries	estimated 2 years with 10 transmissions per day	433.92 MHz ± 100 KHz	< 1 mW e.r.p.	Opera	-10° ÷ +55°	from 0 to 8	25 m in open space, 15 m indoors	54	70x27x70 h	200

Nice

# Era Key switch

Surface mounted and recessed key switches with automatic return lock, European or standard cylinder.



EKSEU



EKSIEU



EKS



EKSI

Switches in anti-intrusion version with metal body.

**Ultra-thin:** protrudes from the wall by just 13 mm in the recessed versions (32 mm and 45 mm in the surface mounted versions).

Electrical contacts and levers protected by a plastic case.

Can be used as a direct motor command in mains-powered applications (230 VAC).

**Flexible:** recessed versions with bowl for new installations and adaptable to existing installations using the EKA02 finishing kit.

**Guaranteed safety:** ten different Era surface mounted key switches available to manage installations physically close to each other in total safety and keep track of them for future replacement.

## KEY SWITCHES

Code	Description	Pcs./pack
<b>EKSEU</b>	Era series key switch, European cylinder, for surface mounting	1
<b>EKSIEU</b>	Era series key switch, European cylinder, for recess mounting	1
<b>EKS1001</b>	Era series key switch, for surface mounting, code 1001	1
<b>EKS1002</b>	Era series key switch, for surface mounting, code 1002	1
<b>EKS1003</b>	Era series key switch, for surface mounting, code 1003	1
<b>EKS1004</b>	Era series key switch, for surface mounting, code 1004	1
<b>EKS1005</b>	Era series key switch, for surface mounting, code 1005	1
<b>EKS1006</b>	Era series key switch, for surface mounting, code 1006	1
<b>EKS1007</b>	Era series key switch, for surface mounting, code 1007	1
<b>EKS1008</b>	Era series key switch, for surface mounting, code 1008	1
<b>EKS1009</b>	Era series key switch, for surface mounting, code 1009	1
<b>EKS1010</b>	Era series key switch, for surface mounting, code 1010	1
<b>EKSI</b>	Era series key switch, recessed	1

## ACCESSORIES

Code	Description	Pcs./pack
<b>CHS</b>	Neutral key for EKS, EKSI	1
<b>CHEU</b>	Neutral key for EKSEU, EKSIEU	1
<b>EKA03</b>	Bowl for recessed mounting (depth 66 mm) for installing EKSI, EKSIEU. Also compatible with EPLIO, EPLIOB, EDSI, EDSIB	50
<b>EKA02</b>	Finishing kit for installing EDSI, EDSIB, EKSI, EKSIEU	10

## TECHNICAL SPECIFICATIONS

	Contact range	Protection class (IP)	Dimensions (mm)	Weight (g)
<b>EKSEU</b>	10 (2) A - 250 VAC	44	70x43x70 h	490
<b>EKSIEU</b>			70x66+13x70 h	530
<b>EKS1001, EKS1002, EKS1003, EKS1004, EKS1005, EKS1006, EKS1007, EKS1008, EKS1009, EKS1010</b>			70x32x70 h	360
<b>EKSI</b>			70x66+13x70 h	450

# Era Transponder reader

Proximity reader for transponder cards and badges, Flor-m bi-modal transmitters, also with Nice BlueBUS connection technology.



ETP

MOCARD  
MOCARDP

HSB1

## Easy to programme:

- 2 programming modes: Easy or Professional;
- lets you determine which cards/badges to enable in the system;
- the number of times a specific card/badge can be used can be programmed;
- 255 memorisable cards/badges expandable, on ETP, up to 510 cards/badges with BM1000 additional second memory;
- 2 modes (static and dynamic) to activate two different commands (ETP version).

**Nice BlueBUS technology:** available with the Nice BlueBUS system (ETPB), allowing easy connection to the control unit of all devices with just two wires, simply by connecting them in parallel, plus other exclusive functions:

- 2 modes (static and dynamic) to activate two different commands chosen from the 6 available (e.g. step-by-step, close, open), depending on the control unit to which they are connected;
- an automation lock/unlock can be added;
- up to 4 EDBSB/EDSIB and ETPB control devices can be connected via Nice BlueBUS, including in a mixed configuration.

**HSB1 transponder badge:** practical to use, can be added to a keyring to always be at hand.

## PROXIMITY READER

Code	Description	Pcs./pack
<b>ETP</b>	Proximity reader for MOCARD and MOCARDP transponder cards for use with MORX Decoder	1
<b>MORX</b>	Decoder for 1 ETP or up to 4 EDS/EDSI connected in parallel, with one BM1000 memory for 255 combinations	1
<b>BM1000</b>	Additional memory for a further 255 combinations	5

## PROXIMITY READER WITH NICE BLUEBUS TECHNOLOGY

Code	Description	Pcs./pack
<b>ETPB</b>	Proximity reader for transponder cards, with Nice BlueBUS technology	1

## ACCESSORIES

Code	Description	Pcs./pack
<b>MOCARD</b>	Transponder card	10
<b>MOCARDP</b>	Transponder card, with sequential code for multiple insertion	10
<b>HSB1</b>	Transponder badge, with sequential code for multiple insertion	10

## TECHNICAL SPECIFICATIONS

	Description	Detection distance (cm)	Protection class (IP)	Dimensions (mm)	Weight (g)
<b>ETP</b>	reader for MOCARD, MOCARDP and HSB1	3 ÷ 6	54	70x26x70 h	265

	Memory capacity	Relay range	Power supply	Maximum draw	Protection class (IP)	Operating temperature (°C min./max.)	Dimensions (mm)	Weight (g)
<b>MORX</b>	2 BM1000 for max. 510 MOCARD and MOCARDP or combinations	max. 500 mA and 48 VAC/ VDC	10 - 35 VDC 12 - 28 VAC	24 VDC=70 mA 24 VAC=200 mA 12 VDC=150 mA 12 VAC=300 mA (with 1 MOM or 4 MOTs)	30	-20 ÷ +55	98x42x25 h	65



MORX

## TECHNICAL SPECIFICATIONS WITH NICE BLUEBUS TECHNOLOGY

	Power supply	Draw	Detection distance (cm)	Protection class (IP)	Dimensions (mm)	Weight (g)
<b>ETPB</b>	via BlueBUS	2 BlueBUS unit	up to 4	54	70x26x70 h	270

Nice

# Era Post

**Outdoor aluminium posts for photocells, switches and proximity readers with heights of 500 mm and 1000 mm.**

**Modern design:** new line of posts for mounting medium and large photocells.

**Easy installation:** simplified mounting to create your own security perimeter in complete freedom.

Code	EPW/EPMB	EPMO/EPMOB	EPMOR	EPL/EPLB	EPLO/EPLOB	EDS/EDSB	EDW	ETP/ETPB	EKS	EKSEU
PPH1	•	•		•	•					
PPH2	•	•		•	•	•*	•*	•*	•*	•*
PPH3	•	•								
PPH4	•	•								
PPK						•	•	•	•	•

\* Installation requires the EKA01 adapter.



PPH3

PPH1

PPH4

PPH2

PPK

Code	Description	Pcs./pack
PPH1	Aluminium post with protected housing for 1 photocell, Medium and Large size, 500 mm h	2
PPH2	Aluminium post with protected housing for 1 photocell, Medium and Large size, 1000 mm h	2
PPH3	Aluminium post with protected housing for 1 photocell, Medium size, 500 mm h	2
PPH4	Aluminium post with protected housing for 1 photocell, Medium size, 1000 mm h	2
PPK	Aluminium post with housing for 1 switch, 1100 mm h	2
EKA01	Plug for mounting EKS, EKSEU, EDS, EDSB, EDSW, ETP, ETPB, on PPH2 post	1

Nice

# Era Light

## Flashing LED signal light.



**Universal:** the flashing light is available in two versions: 90-240 VAC and 12-36 VDC.

Thanks to the wide range of power supplies, ELAC is compatible with different electrical standards and can also be installed in areas at risk of voltage surges.

**Practical:** body particularly shockproof, designed for fixing in various positions.

**Low consumption:** thanks to the LED, ELAC and ELDC technology, they consume about 80% less than traditional flashing lights.

**All versions have an integrated 433.92 MHz antenna.**

Protection class IP44.

Code	Description	Pcs. Pack
<b>ELAC</b>	Neutral, LED light, 90-240 VAC, for compatible control units	1
<b>ELDC</b>	Neutral, LED light, 12-36 VAC, for compatible control units	1

### TECHNICAL SPECIFICATIONS

Code	ELAC	ELDC
<b>TECHNICAL SPECIFICATIONS</b>		
Power supply	90-240 VAC, 50/60 Hz	12-36 VDC
Maximum draw* (mA)	36	230
Maximum power* (W)	5	5,6
Bulb	White LED	
Internal flashing light	Yes	
<b>PERFORMANCE DATA</b>		
Max. operating cycle	33% (5s ton, 10s toff)	50% (5s ton, 5s toff)
<b>DIMENSIONAL AND GENERAL DATA</b>		
Protection class (IP)	44	
Operating temperature (°C Min/Max)	-20 ÷ +50	
Dimensions (mm)	132x72x155	

\* Consumption measured with LED always on.

### TABLE OF FLASHING LIGHT/CONTROL UNIT COMPATIBILITY

Code	MC200	DPRO500	MC800	A924	MC824H	MC424L	WALKY	HYKE	ROAD	ROBUS	RUN	NAKED / SLIGHT	TUB	SPY	SPIN / SPINBUS	TEN	SOON	S/M/L BAR	WIDE
<b>ELAC</b>	•	•	•										•						
<b>ELDC</b>				•	•	•	•	•	•	•	•	•		•	•	•	•	•	•

**VERSATILE: CAN BE MOUNTED ON A SURFACE, POST OR WALL**

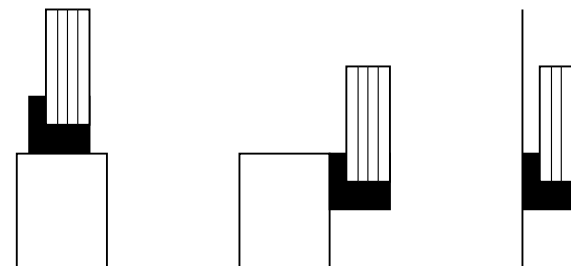

Nice

# Wallyght

## Multifunction LED light.



**Single 12/24 VAC/VDC powered version with flashing, courtesy or twilight light function.**

**A new idea for heaps more safety:** connected to the relevant outputs in the control units, Wallyght can function as a signal light, normal flashing light, or courtesy light to illuminate the surroundings.

Connected to the 12/24 VAC/VDC power output, Wallyght can remain on permanently, or it can come on at dusk and switch off at dawn by activating the integrated twilight sensor.

**High efficiency, extra-long life:** the two 1 W LEDs have a life of 70,000 hours (continuous use).

**Horizontal, wall or ceiling mounting:** together with the possibility of directing the light beam and the compactness of the IP44 box, makes Wallyght even more flexible to use.

Code	Description	Pcs. Pack
WLT	Multifunction LED signal light.	1

### TABLE OF FLASHING LIGHT/CONTROL UNIT COMPATIBILITY

Code	A924	MC824H	MC424L	WALKY	HYKE	ROAD	ROBUS	RUN	NAKED SLIDING 400/SLIGHT	SPY	SPIN / SPINBUS	TEN	SOON	S/M/L BAR	WIDE
WLT	•	•	•	•	•	•	•	•	•	•	•	•	•	•	•

### RECOMMENDED INSTALLATION DIAGRAMS

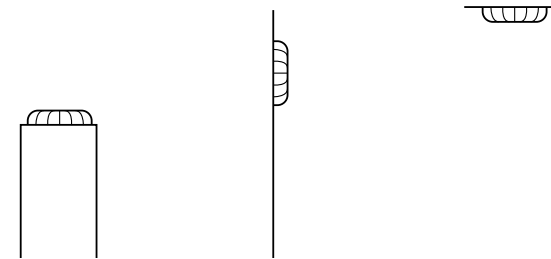

### PATH INDICATORS ON DRIVEWAY



### COURTESY LIGHT

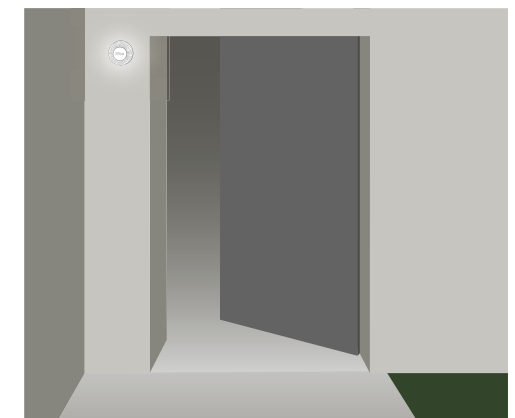

Nice

# Solemyo

## Solar power system.



Available in a KIT



PSY24

SYP30

24V

Solemyo

**Solemyo is a solar power system for gate, garage door and road barrier automation systems without connection to mains power.**

**Installable anywhere:** without the need for connections or excavations even in the most remote locations or those difficult to access with mains power.

**More savings and respect for the environment,** thanks to free and clean solar energy: a smart, environmentally friendly and cost-effective choice.

**Low consumption and no blackouts:** the extended duration of the energy reserve, together with the low consumption of the automations, guarantees operation even in the case of lengthy cloud cover.

**Lower consumption, more autonomy:** even at night or in periods of prolonged cloudiness, everything will work perfectly, ensuring comfort and safety.

**Simple to use:** as an alternative to the photovoltaic module, the SYA1 auxiliary power supply can be used to quick charge the battery via 230 VAC mains power.

LED indication of full charge.



### Photovoltaic panel SYP30

Sold separately, ideal for all situations with low sun exposure or for automations with more intense use.

**Installation tips:** if you need to install two or more solar panels in parallel, we recommend purchasing the Solemyo system codes individually to increase the charging capacity of the system, or to use a single SYA1 power supply unit to charge multiple PSY24 battery boxes.

### TECHNICAL SPECIFICATIONS

Code	PSY24	SYP30	SYA1
Power supply (VAC 50/60 Hz)		-	110 ÷ 240
Normal voltage (V)		24	-
Maximum current (A)	10		-
Peak current (Wp)	-	30	-
Maximum power (W)		-	60
Nominal battery capacity (Ah)	20		-
Protection class (IP)	44		-
Operating temperature (°C Min/Max)	-20 ÷ +50*	-40 ÷ +85	0 ÷ +40
Full charge time (hours)	~ 15**		-
Dimensions (mm)	235x170x258 h	450x25x550 h	132x58x30 h
Weight (kg)	14	3,5	0,345

\* 0 - 40 when charged from mains with the SYA1 power supply unit.

\*\* With mains power supply unit.

### INSTALLATION DIAGRAM

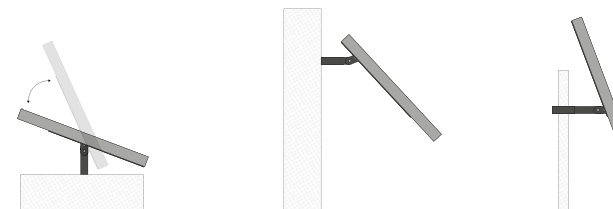

Flexible: Solemyo fits perfectly into any type of system.

### ACCESSORIES



**SYA1**  
Power supply for mains charging of PSY24 battery.

Pcs./pack 1

Nice

## Mechanical sensitive edges



CMA

**Mechanical sensitive edges, safe and easy to install.**

**CMA** is the high mechanical edge pre-mounted in 1.5 - 1.7 - 2 - 2.5 m long aluminium profiles, ideal for mounting on sliding or swing doors.

**CMBK** is the low mechanical edge construction kit: for edges up to 4 m (CMBK4) and edges up to 6 m (CMBK6), ideal for the safety of garage doors in general, up-and-over doors and sectional doors.

### MECHANICAL SENSITIVE EDGES

Code	Description	Pcs. Pack
High mechanical edge, with aluminium profiles in 1.5 - 1.7 - 2 - 2.5 m sections, dimensions in mm 36x75 h:		
<b>CMA 1,5MT</b>	Length 1.5 m	1
<b>CMA 1,7MT</b>	Length 1.7 m	1
<b>CMA 2MT</b>	Length 2 m	1
<b>CMA 2,5MT</b>	Length 2.5 m	1
<b>CMBK4</b>	Low mechanical edge construction kit, for 4 m aluminium profiles (for use with CB)	1
<b>CMBK6</b>	Low mechanical edge construction kit, for 6 m aluminium profiles (for use with CB)	1

### ACCESSORIES FOR SENSITIVE EDGES

Code	Description	Pcs. Pack
<b>TCE</b>	Sensitive edge control interface	1



TCE

## Inductive magnetic detector loop



LP21



LP22

**The inductive magnetic detector loop system is used to detect vehicles and control vehicle transit in the presence of automated gates and garage doors and road barrier and car park management systems. Two versions are available, to control one or two magnetic loops.**

### Easy to use

Even more intuitive programming and use thanks to the simple DIP switch function control. The user can set the parameters directly on the device. For example, the detection sensitivity of the loop detectors can be adjusted to 4 different levels to meet different installation requirements. The LP22 detector enables the direction of vehicles passing over the magnetic loops to be determined.

### Diagnostics

Both inductive detectors are now with a front "RESET" button to quickly reset the default functions if needed. The LEDs on the detectors provide continuous diagnostics.

### Performance

The detector can calibrate the essential parameters regularly to guarantee correct system operation. Fast response time (12 ms). Low power consumption of 0.5 W in standard use conditions. Operating temperature between -37° C and +70° C.

Code	Description	Pcs. Pack
<b>LP21</b>	Single-channel metal mass detector. 12 or 24V power supply	1
<b>LP22</b>	Two-channel metal mass detector. 12 or 24V power supply	1

# FT210

Pair of optical devices for sensitive edges.



PPH2

PPH1

FA1

**GATES**

1. TCB65 resistive sensitive edges
2. TX FT210 with battery power
3. RX FT210

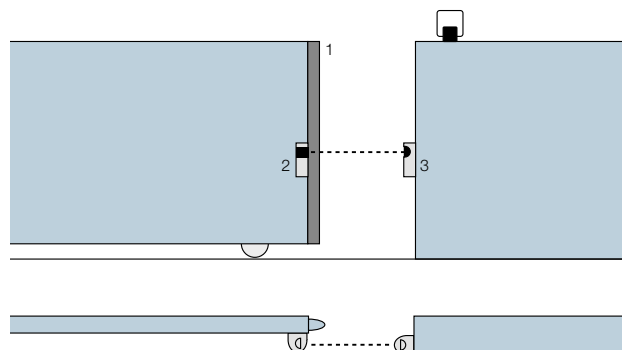

**Optical devices, with wireless transmitter for mounting on moveable leaf, adjustable through 210° along the horizontal axis and 30° along the vertical axis for a system perfectly compliant with standards.**

**Attention to people's safety and product quality.**

An FT210/ FT210B device combined with an 8.2 KOhm resistive sensitive edge (type TCB65) allows the "main closing edge" safety level required by EN12453 to be achieved for any "type of use" and "type of activation".

The FT210/ FT210B device, combined with resistive sensitive edges (8.2 KOhm), is either single-fault safe (category 3 according to EN 954-1) or can be used with automations with self-diagnosis at the beginning of each manoeuvre (category 2 according to EN 954-1).

**More models**

Versions with relay output (FT210) or Nice

BlueBUS technology (FT210B), available with 2 Ah battery kit (FTA2) and 7 Ah battery kit (FTA1), for intensive use.

**Cutting-edge technology**

The anti-collision circuit prevents interference with other detectors, even when not synchronised.

The FT210/FT210B optical devices are fitted with a special sensor able to detect when the gate is stationary, remaining in low-consumption mode and only functioning when the gate is moving.

Range adjustable in 2 levels; alignment with proportional LED for easy and safe installation.

**Suitable for any architectural context and easy to install.**

**Small size:** 46x128x45 mm; electrical connection also possible from underneath the box.

**Ultra-sturdy and safe** Polycarbonate body; FA1 vandal-proof metal shell (optional); transmitter battery partially flat indicator.

Code	Description	Pcs. Pack
<b>FT210</b>	Pair of optical devices for sensitive edges with mounting on moveable leaf, adjustable through 210°, with relay output. Battery kit (FTA1/FTA2) obligatory	1
<b>FT210B</b>	Pair of optical devices for sensitive edges with mounting on moveable leaf, adjustable through 210°, with BlueBUS technology. Battery kit (FTA1/FTA2) obligatory	1

**TECHNICAL SPECIFICATIONS**

	Estimated range (m)	Power supply	Draw	Protection class (IP)	Operating temperature (°C min./max.)	Relay range	Dimensions (mm)	Weight (g)
<b>FT210</b>	10 (residential), 15 (industrial)	RX: 12-24 VAC/ VDC limits: 18-35 VDC, 10-28 VAC TX: 3.6 V lithium battery	RX: 120 mA - 12 V, 70 mA - 24 V TX: 20 uA gate stationary, 450 uA gate in operation	44	-20 ÷ +55	max. 500 mA and 48 V	46x45x128 h	300
<b>FT210B</b>		RX: the device can only be connected to "BlueBUS" networks	1 BlueBUS TX unit: 20 uA gate stationary, 450 uA gate in operation			-		280

**ACCESSORIES**

Code	Description	Pcs. Pack
<b>FA1</b>	Vandal-proof metal shell	2
<b>FA2</b>	Bracket for fixing to PPH1 and PPH2 posts	5
<b>FTA1</b>	7 Ah battery kit for FT210/FT210B transmitters, for intensive use	1
<b>FTA2</b>	2 Ah battery kit for FT210/FT210B transmitters	1
<b>PPH2</b>	Aluminium post for 2 photocells, 1000 mm h	2
<b>PPH1</b>	Aluminium post for 1 photocell, 500 mm h	2

BlueBus

Nice

# F210

## Adjustable synchronised photocells.



PPH2

PPH1

F210 - FA1

### ACCESSORIES

#### TECHNICAL SPECIFICATIONS

	Power supply	Draw with 24 VDC power supply	Draw with 24 VAC power supply	BlueBUS output	Protection class (IP)	Operating temperature (°C min./max.)	Dimensions (mm)	Weight (g)
<b>IB</b>	16 - 35 VDC 18 - 28 VAC	50 mA (add approx. 50 mA for each pair of photocells)	44 mA (add approx. 40 mA for each pair of photocells)	one with a max. load of 9 BlueBUS units	30	86x58x22 h	86x58x22 h	72



IB



FA1

**Synchronised photocells, adjustable through 210° along the horizontal axis and 30° along the vertical axis.**

**Perfect installations, simply.**

#### The 210° solution

With Nice F210 and F210B photocells, the beam can be adjusted through 210° along the horizontal axis, making the system safer and simplifying installation: often the gate leaf or garage door to be automated runs flush with the wall and there is not enough space to mount the photocells.

#### Many models, many advantages

The new photocells are available with relay output (F210) or Nice BlueBUS technology (F210B).

With the latter, all devices can be easily connected to the control unit with just two wires.

The IB interface allows connection of presence

detectors with Nice BlueBUS technology to control units without BlueBUS system.

The system automatically acquires devices connected to the BlueBUS network.

**Suitable for any architectural context and easy to install.**

**Small size:** 46x128x45 mm; electrical connection also possible from underneath the box.

**Ultra-sturdy and safe** Polycarbonate body; FA1 vandal-proof metal shell (optional).

**State-of-the-art technology** Anti-glare circuit, automatic synchronisation between several pairs of photocells to prevent interference between detectors.

High range adjustable in 2 levels; alignment with proportional LED for easy and safe installation.

Code	Description	Pcs. Pack
<b>F210</b>	Pair of synchronised photocells adjustable through 210° with relay output	1
<b>F210B</b>	Pair of synchronised photocells adjustable through 210° with Nice BlueBUS technology	1

#### TECHNICAL SPECIFICATIONS

	Estimated range (m)	Power supply	Draw	Protection class (IP)	Operating temperature (°C min./max.)	Relay range	Dimensions (mm)	Weight (g)
<b>F210</b>	10 (30 with jumper cut)	without 24 VAC/VDC jumper limits: 18-35 VDC, 15-28 VAC with 12 VAC/VDC jumper limits: 10-18 VDC, 9-15 VAC	25 mA RX, 30 mA TX	44	-20 ÷ +55	max. 500 mA and 48 V	46x45x128 h	230
<b>F210B</b>		the device can only be connected to "BlueBUS" networks	1 BlueBUS unit			-		

#### ACCESSORIES

Code	Description	Pcs. Pack
<b>IB</b>	Interface for connecting F210B BlueBUS photocells to control units without BlueBUS system	1
<b>FA1</b>	Vandal-proof metal shell	2
<b>FA2</b>	Bracket for fixing to PPH1 and PPH2 posts	5
<b>PPH2</b>	Aluminium post for 2 photocells, 1000 mm h	2
<b>PPH1</b>	Aluminium post for 1 photocell, 500 mm h	2

BlueBus

Nice

# Kio

Key switch for low-voltage contacts.



**With release mechanism for metal cable, ideal for automating sectional doors, rolling doors and folding doors.**

**Convenient:** Kio is both a key switch and a release device; its design makes it effortless to use, and easy to install anywhere, thanks to its very narrow profile.

**Long life:** made from epoxy-powder painted cast aluminium.

**Easy:** an LED light makes the switch easy to find even in total darkness.

**Safer:** encrypted key. Release activated either by directly opening the door or via a winder.

**The first product to incorporate key control and motor release functions.**

Code	Description	Pcs. Pack
<b>KIO</b>	Key switch for low-voltage contacts, with release mechanism for metal cable	1
<b>KA1</b>	Kit with 6 m metal cable for KIO	1



KIO



KA1

Nice

# Kiomini

Aluminium key switch.



**With control button and release mechanism for metal cable.**

**Practical:** Kiomini incorporates a lever for wire release and a control button to operate a single-phase motor either directly or via a control unit.

**Resistant:** anti-intrusion body in cast aluminium. Access to the compartment via a sturdy door closed with a lock.

**Convenient:** the small size makes it simple and compact to install.

Code	Description	Pcs. Pack
<b>KIOMINI</b>	Aluminium key switch with control and release button	1
<b>KA1</b>	Kit with 6 m metal cable for KIO	1



KA1

Nice

# Control units - Selection guide

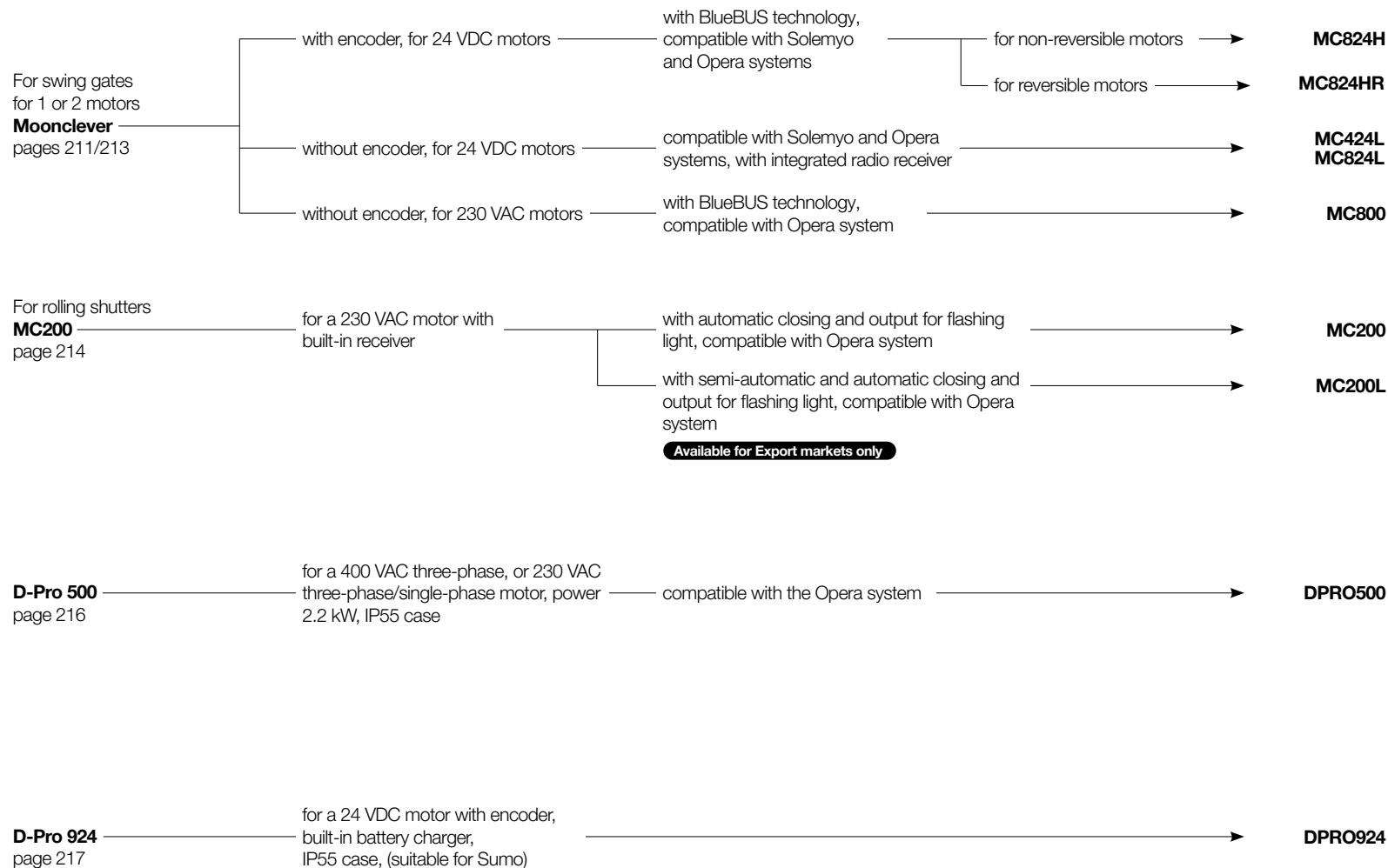

Nice

# Moonclever

Control units for motors for 24 VDC swing gates, with magnetic encoder.

BiDi

Yubii

Solemyo

Opera

BlueBus

24V



With Nice BlueBUS technology, compatible with the Solemyo solar power kit (MC824H, MC824L) and Opera system for automation management, programming and diagnostics, even remotely.

**Compatible with the Opera system** whose Pro-View multifunction display (mountable in the box) enables the system to be personalised, modifying the opening and closing positions, staggered closing of the leaves and decelerations and editing parameters such as force, speed and obstacle sensitivity for each motor. Microprocessor logic: Moonclever control units combine the advantages of the Opera system with the advanced functions of the Nice systems (gradual start and deceleration, automatic memorising of both limit switch positions and pedestrian pass door function).

**Safe and reliable:** thanks to obstacle detection

with dual technology throughout door/gate travel, with provision for connecting the latest resistive sensitive edges. **Smart:** control unit signals correct power supply and operation when switching on; automatic fault diagnosis and flashing light and confirmation LED light indicators.

**Savings and respect for the environment:** when connected to the buffer battery or Solemyo kit (MC824H, MC824L), consumption in standby drops to just 0.1 W.

**Ultra-simple installation:** thanks to the BlueBUS system allowing connections with just two wires between the control unit, motors and accessories.

**No blackouts:** operation in event of power failure with the optional batteries (PSS324) for housing in the control unit.

**Radio receiver:** with provision for SM plug-in receivers.

Code	Description	Pcs./pack
<b>MC824H</b>	Control unit for one or two 24 V non-reversible motors with encoder, with Nice BlueBUS technology and compatible with Opera and Solemyo	1
<b>MC824L</b>	Control unit for one or two Oltre 1824 motors without encoder, with Nice BlueBUS technology and compatible with Opera and Solemyo	1
<b>MC824HR</b>	Control unit for one or two 24 V reversible motors with encoder, with Nice BlueBUS technology and compatible with Opera	1

## TECHNICAL SPECIFICATIONS

Code	MC824H, MC824L, MC824HR
Mains power supply (VAC 50/60 Hz)	230 ± 10%
Battery power supply (VDC)	21 ÷ 28
Max. motor power and current (VA; A)	360 (W); 15
Max. current 24 V services (A)	0,2
Max. flashing light output voltage and power (V; W)	12; 21
Max. GO light output voltage and power (V; W)	12; 2
Max. electric lock output voltage and power (VAC; VA)	12; 15
Operating time OT (s)	-
Pause time PT (s)	1 ÷ 250
Delay 1st motor in opening TRA (s)	Programmable
Delay 2nd motor in closing TRC (s)	Programmable
Courtesy light time TCOR (s)	0: 250
Pre-flash time TPRE (s)	0: 10
Force adjustment (%)	-
Obstacle detection (sensitivity)	min - max
Case dimensions (mm)	230x125x300 h

## COMMON ACCESSORIES



**PSS324**  
24 V battery with integrated battery charger.

Pcs./pack 1



**MCA3**  
Spare control unit for MC824HR \*.

Pcs./pack 1



**MCA4**  
Spare control unit for MC824L.

Pcs./pack 1



**MCA1**  
Spare control unit for MC824H.

Pcs./pack 1

\* Not compatible with Solemyo Kit and PSS324 \*\* Not compatible with Solemyo Kit.

Nice

# Moonclever

Control unit for 24 VDC motors for swing gates, without encoder.

BiDi

Yubii

Solemyo

Opera



24V

Compatible with the Solemyo solar power system.

**Compatible with the Opera system** whose Pro-View multifunction display (mountable in the box) enables the system to be personalised, modifying the opening and closing positions, staggered closing of the leaves and decelerations and editing parameters such as force, speed and obstacle sensitivity for each motor.

**Safe and reliable:** thanks to obstacle detection throughout the travel, with provision for connection of latest generation resistive sensitive edges.

**Smart:** automatic fault diagnosis and indication via flashing light and confirmation LED.

**Easy and complete manual programming,** thanks to the three keys and 8 LEDs.

**Savings and respect for the environment:** when connected to the buffer battery or Solemyo kit, consumption in standby drops to just 0.1 W.

**No blackouts:** operation in event of power failure with the optional batteries (PSS124) for housing in the control unit.

**Built-in radio receiver:** the built-in radio card is also compatible with the Nice Flo and Smilo systems. Can memorise up to 100 transmitters. The control unit is designed to take SM plug-in receivers.

Code	Description	Pcs./pack
MC424L	Control unit for one or two 24 V motors without encoder, with integrated radio receiver and compatible with Solemyo and Opera systems	1

## TECHNICAL SPECIFICATIONS

Code	MC424L
Mains power supply (VAC 50/60 Hz)	230 ± 10%
Battery power supply (VDC)	21 ÷ 28
Max. motor power and current (VA; A)	75; 3
Max. current 24 V services (A)	0,2 +0,1
Max. flashing light output voltage and power (V; W)	24; 25
Max. GO light output voltage and power (V; W)	24; 5
Max. electric lock output voltage and power (VAC; VA)	12; 15
Operating time OT (s)	-
Pause time PT (s)	5 ÷ 180
Delay 1st motor in opening TRA (s)	0 - 50% TL
Delay 2nd motor in closing TRC (s)	-
Courtesy light time TCOR (s)	-
Pre-flash time TPRE (s)	3
Force adjustment (%)	-
Obstacle detection (sensitivity)	1 ÷ 8
Case dimensions (mm)	230x125x300 h

## COMMON ACCESSORIES



**PSS124**  
24 V battery with integrated battery charger.

Pcs./pack 1



**MCA2**  
Spare control unit for MC424L.

Pcs./pack 1

Nice

# MC800

## Control unit for 230 V motors for swing gates.

BiDi

Yubii

Opera

BlueBus

230V



With Nice BlueBUS technology, compatible with the Opera system for automation management, programming and diagnostics, even remotely.

Compatible with the Opera system whose Pro-View multifunction display enables the system to be personalised, modifying the opening and closing positions, staggered closing of the leaves and decelerations and editing parameters such as force, speed and obstacle sensitivity for each motor.

**Universal power supply:** 120/230 VAC 50/60 Hz.

Microprocessor logic: the MC800 control unit combines the advantages of the Opera system with the advanced functions of the Nice systems (gradual start and deceleration, automatic memorising of both limit switch positions and pedestrian pass door function).

**Smart:** at switch-on, indication of correct power supply and operation of the control unit; automatic fault diagnosis and indication via flashing light and confirmation LED.

**Ultra-simple installation:** thanks to the Blue-BUS system allowing connections with just two wires between the control unit and accessories.

**Radio receiver:** with provision for SM plug-in receivers.

Code	Description	Pcs./pack
<b>MC800</b>	Control unit for one or two 230V motors with Nice BlueBUS technology and compatible with the Opera system	1

### TECHNICAL SPECIFICATIONS

Code	MC800
Mains power supply (VAC 50/60 Hz)	120/230
Max. motor power and current (W; A)	900; 5
Max. current 24 V services (A)	0,2
Max. flashing light output voltage and power (V; W)	120/230; 21
Max. GO light output voltage and power (V; W)	24; 4
Max. electric lock output voltage and power (VAC; VA)	12; 15
Operating time OT (s)	-
Pause time PT (s)	5 - 180
Delay 1st motor in opening TRA (s)	Programmable
Delay 2nd motor in closing TRC (s)	Programmable
Courtesy light time TCOR (s)	0: 250
Pre-flash time TPPE (s)	0: 10
Force adjustment (%)	-
Case dimensions (mm)	230x120x300 h

### COMMON ACCESSORIES



**MCA5**  
Spare control unit for MC800.

Pcs./pack 1

Nice

# MC200

## Control unit for rolling shutters.

Opera

230V

Flor



**MC200** is the control unit designed for controlling and managing motors intended for the automation of shutters, overhead doors, sectional doors, rolling shutters and similar applications.

**Easy to programme** thanks to the MyNice Pro app, connecting the control unit to the Pro-View or BiDi-WiFi.

**Built-in radio card** compatible with Nice FlorR and Opera system transmitters.

**Flexible inputs configuration:** step-by-step or open command, photo or close input, and dedicated input for 8.2 kOhm NO NC resistive sensitive edge.

Complete outputs management with flashing light output, phototest or door status output, and the possibility to connect an external courtesy light.

**Safe:** compatible with photocells (also with phototest function) and resistive sensitive edges, ensuring a high level of safety and compliance with standards.

**Smart and easy to use:** remote connection capability and simplified setup make MC200 a reliable and efficient solution for professional installers.

Code	Description	Pcs./pack
<b>MC200</b>	For a 230 VAC motor for rolling doors, with semi-automatic and automatic closing, with flashing light output and built-in receiver compatible with Flor series transmitters	1

### TECHNICAL SPECIFICATIONS

Code	MC200
Mains power supply (VAC 50/60 Hz)	120 / 230 ± 10%
Max. motor power and current	650 (120V) 1300 (230V)
Power consumption in standby mode	<0.3W
Max. current 24 V services (mA)	100
Max. current Out STB output (mA)	50
Max. flashing light output voltage and power (V; W)	120 - 230; 40
Operating time OT (s)	5 ÷ 120
Pause time PT (s)	1 ÷ 120
Case dimensions (mm)	128x112x43 h

# MC200L

Available for Export markets only

## Control unit for rolling shutters.

Opera

230V

Flor



**MC200L** is the control unit designed for controlling and managing motors intended for the automation of shutters, overhead doors, sectional doors, rolling shutters and similar applications.

**Automatic closing function and supports man-present mode during closing**, ensuring safe and controlled operation.

**Integrated radio receiver** is compatible with Era Inti and Era Flor transmitters.

**Programming is simplified by an acoustic** signal that guides the installer during setup.

**Separate and dedicated inputs are available for Open, Stop and Close commands**, allowing clear and intuitive control.

**Safe:** compatible with NC-type safety edges and with photocells. The photocells can be activated only during closing or in both directions of movement, adapting the safety level to the specific application.

Code	Description	Pcs./pack
<b>MC200L</b>	For a 230 Vac rolling shutter motor, with semi-automatic and automatic closing, flashing light output and with integrated receiver compatible with Opera and Flor series transmitters	1

### TECHNICAL SPECIFICATIONS

Code	MC200L
Mains power supply (VAC 50/60 Hz)	120 / 230 ± 10%
Maximum power and current of motors	1300W (230V)
Power consumption in standby mode	<0.3W
Maximum current for 24 V services (mA)	50
Operating time OT (s)	5 ÷ 120
Pause time PT (s)	1 ÷ 300
Container dimensions (mm)	128x112x43 h

Nice

# D-Pro 500

Control units for motors with mechanical and electronic limit switches.

BiDi

Yubii

Opera

230V

400V



Possibility of both man-present and automatic manoeuvres.

Suitable for all types of motor, single-phase without integrated inverter and three-phase, with 2.2 kW maximum power.

**Easy programming and 2 diagnostics LEDs.**

**High performance:** with possibility of adding a dedicated module for optional potential free outputs.

Compatible with all types of sensitive edges, including wireless.

**Easy to programme:** thanks to the Pro-View multifunction interface for connection via the IBT4N interface (both optional).

**Safe:** protected by a plastic body, to avoid any risk of electrical shock.

**Radio receiver:** dedicated slot for inserting Nice plug-in receivers.

**Smart:** the maintenance service warning can be programmed according to the number of manoeuvres required.

Code	Description	Pcs./pack
<b>DPRO500</b>	Control unit for one 230 VAC, 2.2 kW single-phase motor, or one 400 VAC, 2.2 kW three phase motor	1

## TECHNICAL SPECIFICATIONS

Code	DPRO500
<b>ELECTRICAL SPECIFICATIONS</b>	
Mains power supply (VAC 50/60 Hz)*	1~230 / 3~400
Max. motor power (kW)	2,2
Logic unit power supply (VDC)	24
Power in standby	< 5 VA
Pre-limit input	Programmable
Inputs for external controls	Wired inputs, all programmable
Sensitive edges	Optical, 8.2 kΩ resistive and 8.2 kΩ pneumatic
Extra output	2 programmable potential free contacts (via NDA040 module)
DC output	24 VDC 1st
Stop input	Normally closed contacts

## DIMENSIONAL AND GENERAL DATA

Protection class (IP)	55
Operating temperature (°C Min/Max)	-20 ÷ +50
Dimensions (mm)	210x125x310 h
Weight (kg)	3

## COMMON ACCESSORIES



### NDA040

For optional potential free outputs.

Pcs./pack 1

Nice

# D-Pro 924

**Control unit for 24 V motors for sectional doors, with encoder or electromechanical limit switch, suitable for Sumo.**

BiDi

Yubii

Solemyo

Opera

24V



Compatible with the Solemyo solar power system.

Compatible with the Opera system whose Pro-View multifunction display (mountable in the box) enables the system to be personalised, modifying the opening and closing positions, decelerations and editing parameters such as force, speed and obstacle sensitivity for each motor.

Practical and safe: new box with 3 buttons built into the cover for automation control.

Ample internal space for wiring and accessories.

Protective inner cover guarantees maximum installation safety and prevents accidental damage to the electronics.

Simple: the new programming procedure with button and DIP switch and handy removable terminals makes installation even easier.

Compatible with the IBT4N interface: dedicated slot for connecting Bus T4 compatible accessories and programming interfaces. Complete: the programmable inputs and outputs (with Pro-View), new relay outputs and compatibility with all the most popular sensitive edges on the market (resistive and optical) make it ideal for all requirements.

Safe and reliable: thanks to obstacle detection throughout door/gate travel, with provision for connecting the latest resistive sensitive edges.

Inexpensive to run and environmentally-friendly, autonomous: when connected to the buffer battery or Solemyo kit, consumption in standby is reduced to just 0.1 W.

Smart: automatic fault diagnosis and flashing light and confirmation LED light indicators.

No black-outs: functions during power failures with the optional batteries (PSS124) inserted into the control unit.

Code	Description	Pcs./pack
<b>DPRO924</b>	Control unit for 24V motor (suitable for Sumo), with compatible with Solemyo and Opera	1

## TECHNICAL SPECIFICATIONS

Code	<b>DPRO924</b>
Mains power supply (VAC 50/60 Hz)	230 ± 10%
Battery power supply (VDC)	21 ÷ 28
Max. motor power and current (VA; A)	360 (W); 15
Max. current 24 V services (A)	0,2
Max. flashing light output voltage and power (V; W)	12; 21
Pause time PT (s)	1 : 250
Operating time TL (s) / pause time TP (s)	- / 1 ÷ 1023
Courtesy light time TCOR (s)	0 : 250
Pre-flash time TPRE (s)	0 : 60
Obstacle detection (sensitivity)	min - max
Case dimensions (mm)	210x125x310 h

## COMMON ACCESSORIES



**PS224**  
Buffer battery 24 VDC.  
Pcs./pack 1



**DPCU1**  
Spare control unit for DPRO924.  
Pcs./pack 1



**Nice catalogues:**

**Smart Home**

An integrated, connected and open system to make the home safe, efficient and comfortable.

**Smart Home Solutions**



SCAN ME

**Sun Shading Solutions**

Automation and management systems for awnings, blinds and shutters.

**Sun Shading Solutions**



SCAN ME

**Security**

The Smart Home Security system for the integrated management of your alarm system and Nice automations.

**Security Solutions**



SCAN ME

Our products and our technologies are protected with patents, design models and brands. All violations will be prosecuted.

# We imagined the freedom to explore the world and turned it into a house-system.

Connected, integrated and customisable.  
Safe and easy to use. The smart home system  
is the Nice project that puts the way you want to live  
at the centre of the automation.

Even when you're busy exploring the world.

[www.niceforyou.com](http://www.niceforyou.com)

Nice SpA  
Oderzo, TV, Italy

